

# SERPAC SE520

Electronic Enclosures

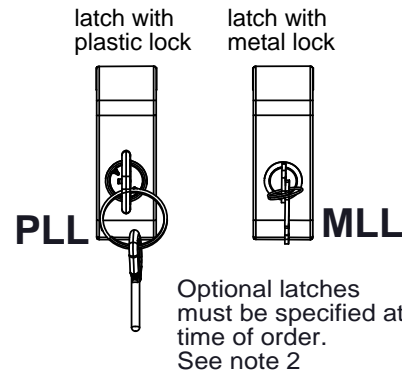
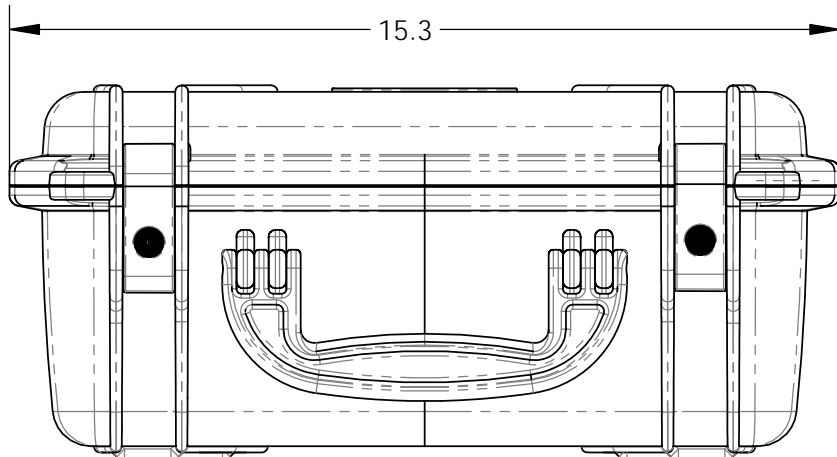
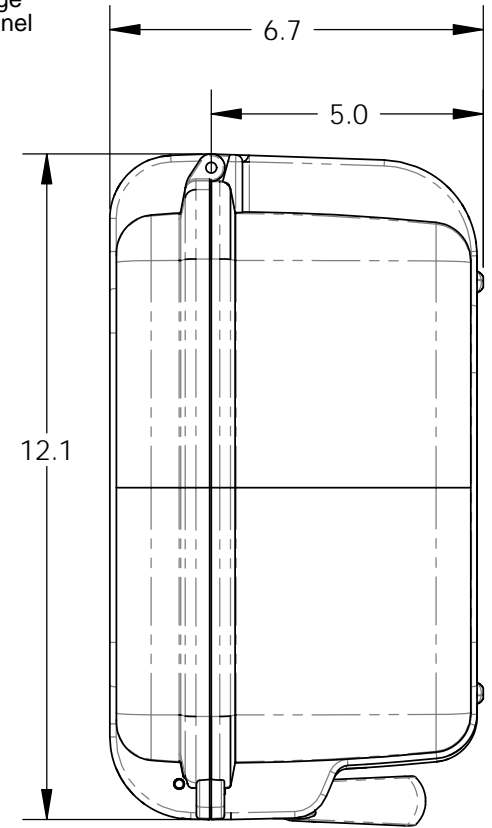
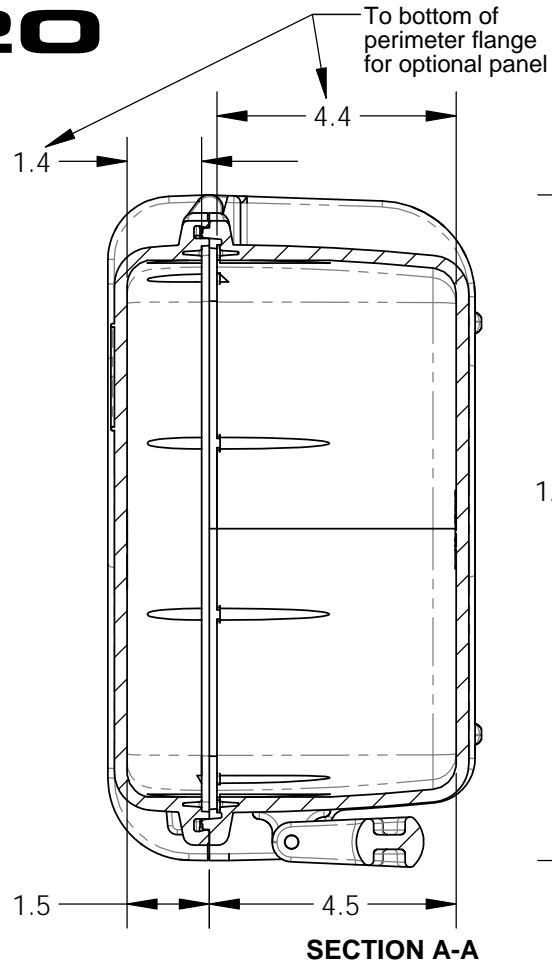
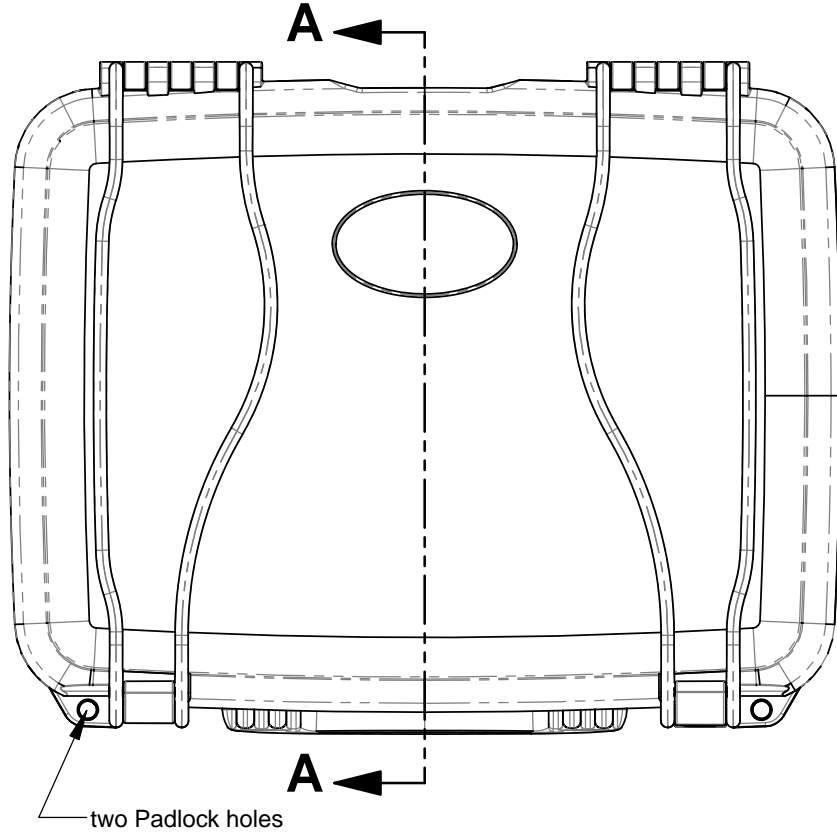

**NOTES:**

- 1) Max. usable inside dimensions are:  
13 1/2" X 9 13/16" X 6" (13.5" X 9.8" X 6.0")
- 2) With Metal Lock Latches p/n SE520ML and Plastic Lock Latches p/n SE520PL are optional.

# Mouser Electronics

Authorized Distributor

Click to View Pricing, Inventory, Delivery & Lifecycle Information:

[SERPAC:](#)

[SE520F,BK](#) [SE520,OR](#) [SE520F,GM](#) [SE520F,OR](#) [SE520F,YL](#) [SE520,YL](#)