

2N6027, 2N6028

Preferred Device

Programmable Unijunction Transistor

Programmable Unijunction Transistor Triggers

Designed to enable the engineer to “program” unijunction characteristics such as R_{BB} , η , I_V , and I_P by merely selecting two resistor values. Application includes thyristor-trigger, oscillator, pulse and timing circuits. These devices may also be used in special thyristor applications due to the availability of an anode gate. Supplied in an inexpensive TO-92 plastic package for high-volume requirements, this package is readily adaptable for use in automatic insertion equipment.

- Programmable — R_{BB} , η , I_V and I_P
- Low On-State Voltage — 1.5 Volts Maximum @ $I_F = 50$ mA
- Low Gate to Anode Leakage Current — 10 nA Maximum
- High Peak Output Voltage — 11 Volts Typical
- Low Offset Voltage — 0.35 Volt Typical ($R_G = 10$ k ohms)
- Device Marking: Logo, Device Type, e.g., 2N6027, Date Code

MAXIMUM RATINGS ($T_J = 25^\circ\text{C}$ unless otherwise noted)

Rating	Symbol	Value	Unit
*Power Dissipation Derate Above 25°C	P_F $1/\theta_{JA}$	300 4.0	mW mW/ $^\circ\text{C}$
*DC Forward Anode Current Derate Above 25°C	I_T	150 2.67	mA mA/ $^\circ\text{C}$
*DC Gate Current	I_G	± 50	mA
Repetitive Peak Forward Current 100 μs Pulse Width, 1% Duty Cycle *20 μs Pulse Width, 1% Duty Cycle	I_{TRM}	1.0 2.0	Amps
Non-Repetitive Peak Forward Current 10 μs Pulse Width	I_{TSM}	5.0	Amps
*Gate to Cathode Forward Voltage	V_{GKF}	40	Volts
*Gate to Cathode Reverse Voltage	V_{GKR}	-5.0	Volts
*Gate to Anode Reverse Voltage	V_{GAR}	40	Volts
*Anode to Cathode Voltage ⁽¹⁾	V_{AK}	± 40	Volts
Operating Junction Temperature Range	T_J	-50 to +100	$^\circ\text{C}$
*Storage Temperature Range	T_{stg}	-55 to +150	$^\circ\text{C}$

*Indicates JEDEC Registered Data

(1) Anode positive, $R_{GA} = 1000$ ohms
Anode negative, $R_{GA} = \text{open}$



ON Semiconductor

<http://onsemi.com>

PUTs
40 VOLTS
300 mW

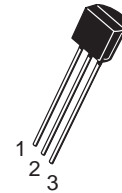

TO-92 (TO-226AA)
CASE 029
STYLE 16

PIN ASSIGNMENT	
1	Anode
2	Gate
3	Cathode

ORDERING INFORMATION

See detailed ordering and shipping information in the package dimensions section on page 271 of this data sheet.

Preferred devices are recommended choices for future use and best overall value.

2N6027, 2N6028

Thermal Characteristics

Characteristic	Symbol	Max	Unit
Thermal Resistance, Junction to Case	$R_{\theta JC}$	75	$^{\circ}C/W$
Thermal Resistance, Junction to Ambient	$R_{\theta JA}$	200	$^{\circ}C/W$
Maximum Lead Temperature for Soldering Purposes ($< 1/16''$ from case, 10 secs max)	T_L	260	$^{\circ}C$

ELECTRICAL CHARACTERISTICS ($T_C = 25^{\circ}C$ unless otherwise noted.)

Characteristic	Fig. No.	Symbol	Min	Typ	Max	Unit
*Peak Current ($V_S = 10$ Vdc, $R_G = 1$ M Ω) 2N6027 2N6028 ($V_S = 10$ Vdc, $R_G = 10$ k ohms) 2N6027 2N6028	2,9,11	I_P	— — — —	1.25 0.08 4.0 0.70	2.0 0.15 5.0 1.0	μA
*Offset Voltage ($V_S = 10$ Vdc, $R_G = 1$ M Ω) 2N6027 2N6028 ($V_S = 10$ Vdc, $R_G = 10$ k ohms) (Both Types)	1	V_T	0.2 0.2 0.2	0.70 0.50 0.35	1.6 0.6 0.6	Volts
*Valley Current ($V_S = 10$ Vdc, $R_G = 1$ M Ω) 2N6027 2N6028 ($V_S = 10$ Vdc, $R_G = 10$ k ohms) 2N6027 2N6028 ($V_S = 10$ Vdc, $R_G = 200$ ohms) 2N6027 2N6028	1,4,5	I_V	— — 70 25 1.5 1.0	18 18 150 150 — —	50 25 — — — —	μA mA
*Gate to Anode Leakage Current ($V_S = 40$ Vdc, $T_A = 25^{\circ}C$, Cathode Open) ($V_S = 40$ Vdc, $T_A = 75^{\circ}C$, Cathode Open)	—	I_{GAO}	— —	1.0 3.0	10 —	nAdc
Gate to Cathode Leakage Current ($V_S = 40$ Vdc, Anode to Cathode Shorted)	—	I_{GKS}	—	5.0	50	nAdc
*Forward Voltage ($I_F = 50$ mA Peak)(1)	1,6	V_F	—	0.8	1.5	Volts
*Peak Output Voltage ($V_G = 20$ Vdc, $C_C = 0.2$ μF)	3,7	V_O	6.0	11	—	Volt
Pulse Voltage Rise Time ($V_B = 20$ Vdc, $C_C = 0.2$ μF)	3	t_r	—	40	80	ns

*Indicates JEDEC Registered Data

(1) Pulse Test: Pulse Width ≤ 300 μsec , Duty Cycle $\leq 2\%$.

2N6027, 2N6028

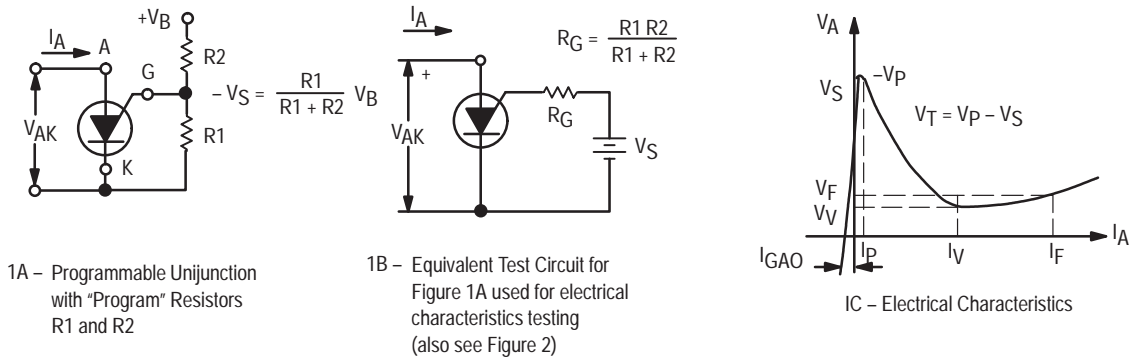

Figure 1. Electrical Characterization

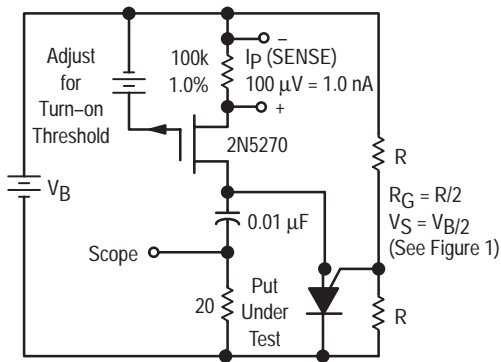

Figure 2. Peak Current (I_p) Test Circuit

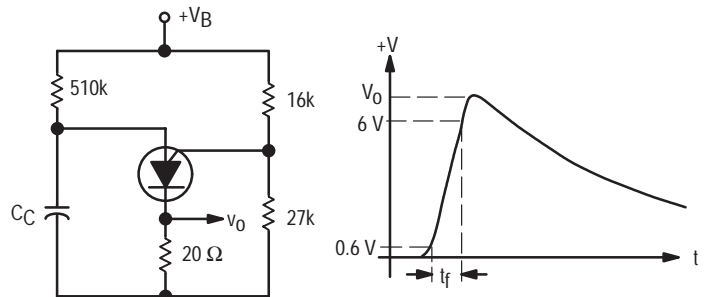

Figure 3. V_0 and t_r Test Circuit

TYPICAL VALLEY CURRENT BEHAVIOR

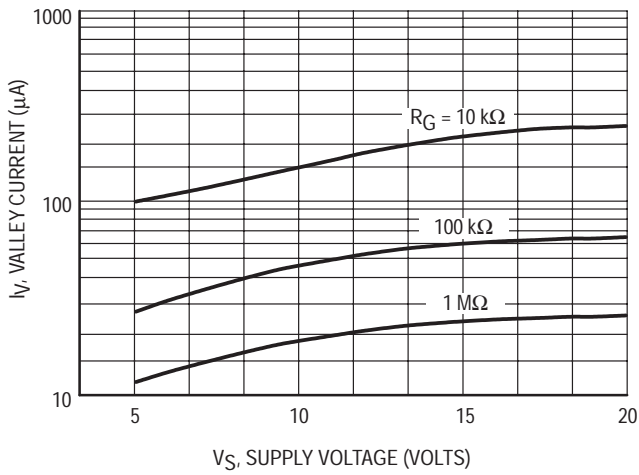

Figure 4. Effect of Supply Voltage

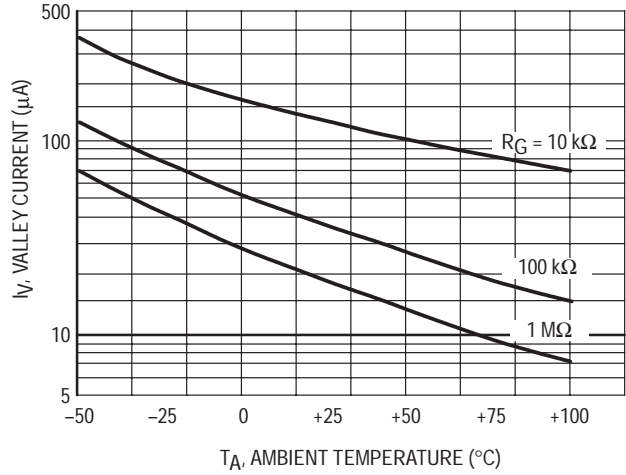

Figure 5. Effect of Temperature

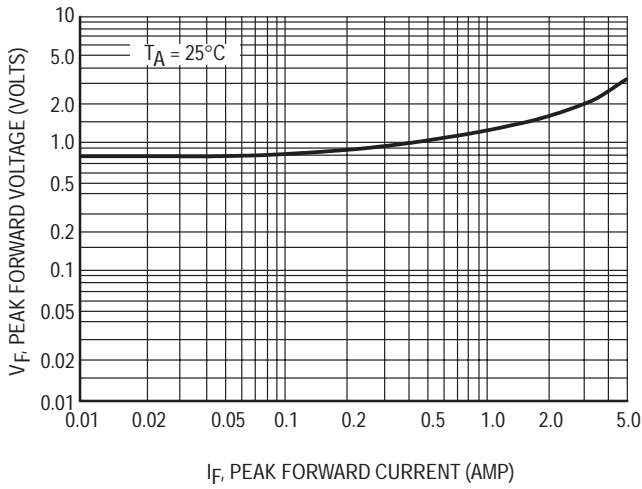

Figure 6. Forward Voltage

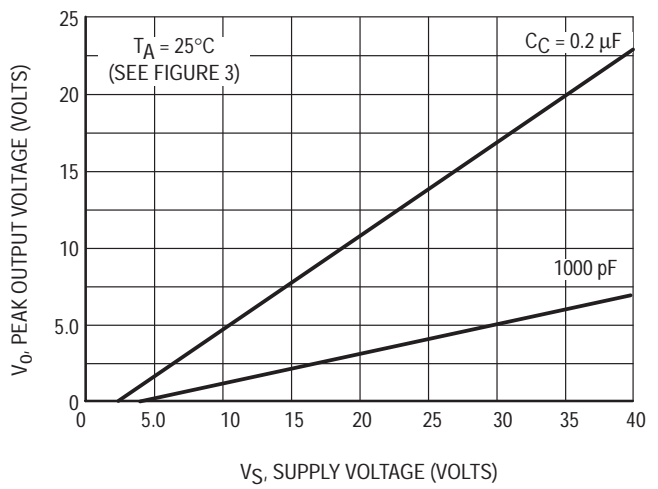

Figure 7. Peak Output Voltage

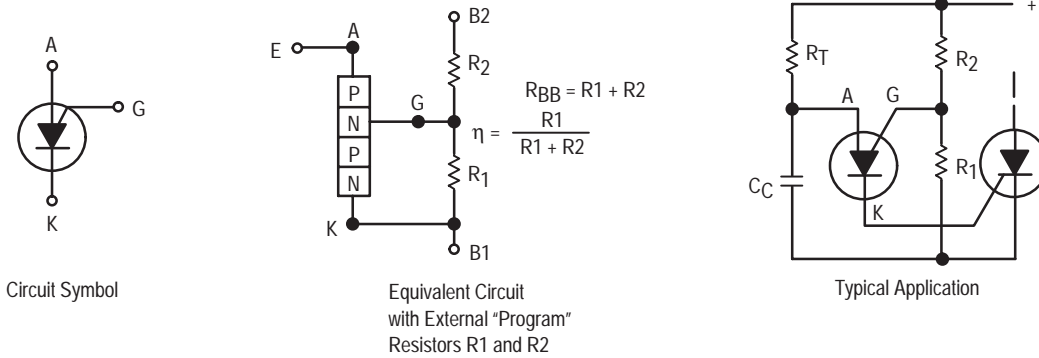

Figure 8. Programmable Unijunction

2N6027, 2N6028

TYPICAL PEAK CURRENT BEHAVIOR

2N6027

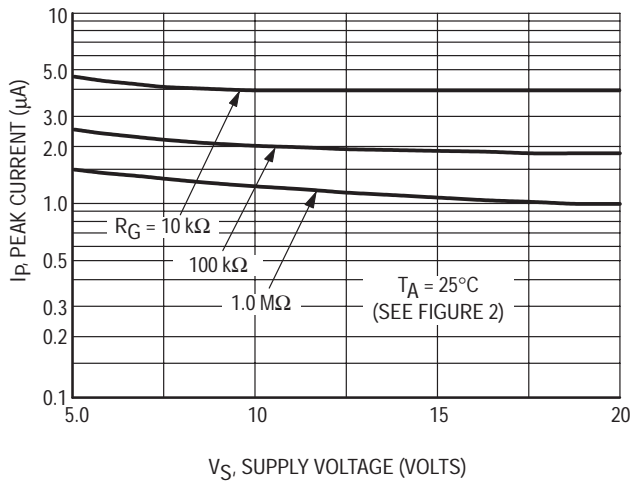

Figure 9. Effect of Supply Voltage and R_G

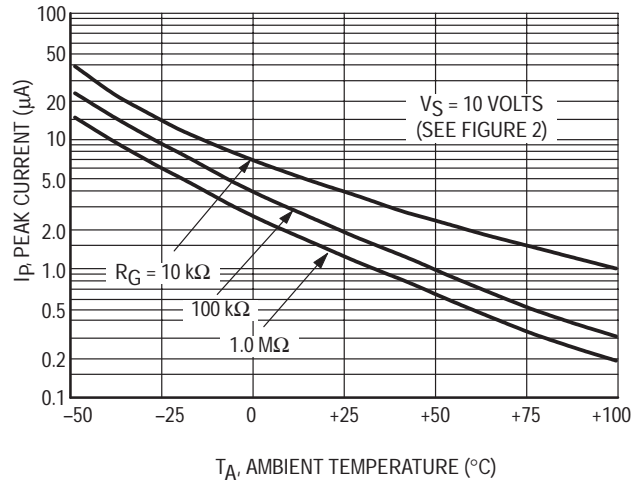

Figure 10. Effect of Temperature and R_G

2N6028

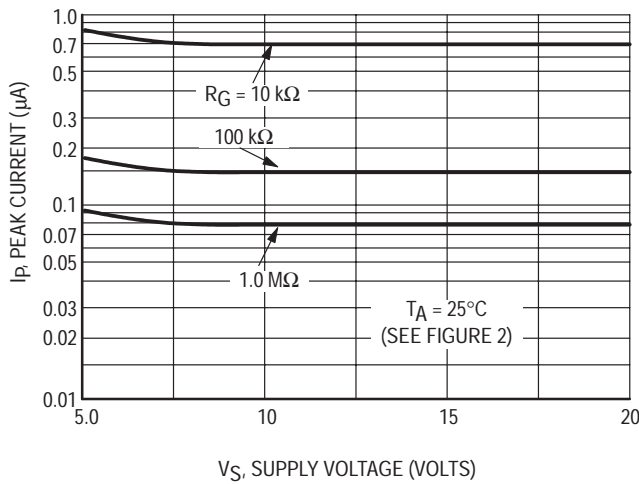

Figure 11. Effect of Supply Voltage and R_G

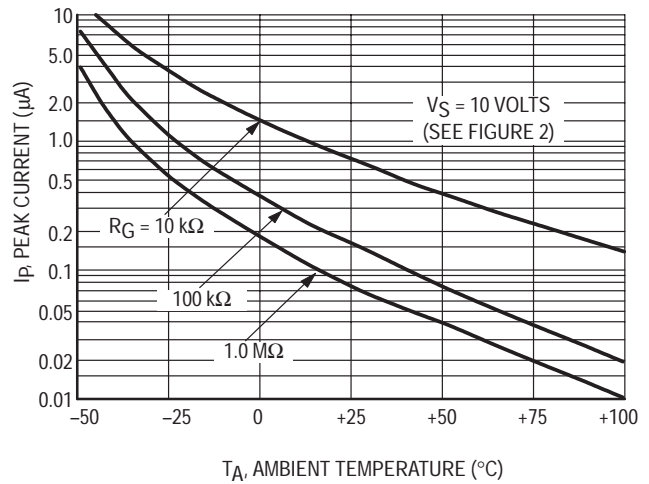

Figure 12. Effect of Temperature and R_G

TO-92 EIA RADIAL TAPE IN FAN FOLD BOX OR ON REEL

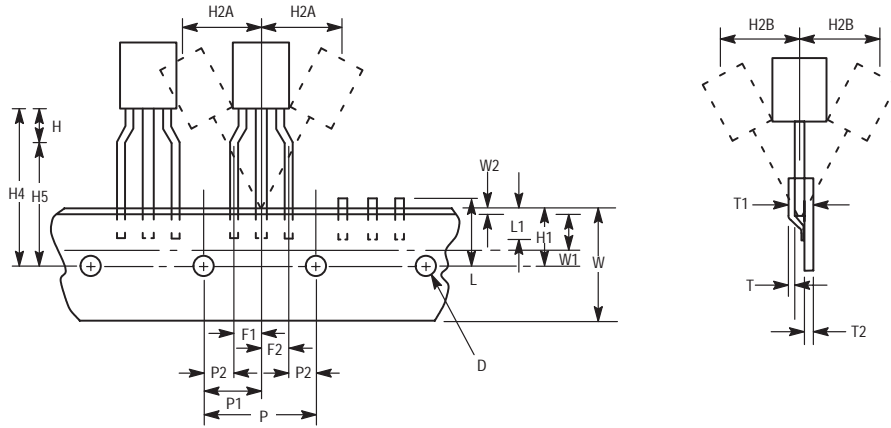

Figure 13. Device Positioning on Tape

Symbol	Item	Specification			
		Inches		Millimeter	
		Min	Max	Min	Max
D	Tape Feedhole Diameter	0.1496	0.1653	3.8	4.2
D2	Component Lead Thickness Dimension	0.015	0.020	0.38	0.51
F1, F2	Component Lead Pitch	0.0945	0.110	2.4	2.8
H	Bottom of Component to Seating Plane	.059	.156	1.5	4.0
H1	Feedhole Location	0.3346	0.3741	8.5	9.5
H2A	Deflection Left or Right	0	0.039	0	1.0
H2B	Deflection Front or Rear	0	0.051	0	1.0
H4	Feedhole to Bottom of Component	0.7086	0.768	18	19.5
H5	Feedhole to Seating Plane	0.610	0.649	15.5	16.5
L	Defective Unit Clipped Dimension	0.3346	0.433	8.5	11
L1	Lead Wire Enclosure	0.09842	—	2.5	—
P	Feedhole Pitch	0.4921	0.5079	12.5	12.9
P1	Feedhole Center to Center Lead	0.2342	0.2658	5.95	6.75
P2	First Lead Spacing Dimension	0.1397	0.1556	3.55	3.95
T	Adhesive Tape Thickness	0.06	0.08	0.15	0.20
T1	Overall Taped Package Thickness	—	0.0567	—	1.44
T2	Carrier Strip Thickness	0.014	0.027	0.35	0.65
W	Carrier Strip Width	0.6889	0.7481	17.5	19
W1	Adhesive Tape Width	0.2165	0.2841	5.5	6.3
W2	Adhesive Tape Position	.0059	0.01968	.15	0.5

NOTES:

1. Maximum alignment deviation between leads not to be greater than 0.2 mm.
2. Defective components shall be clipped from the carrier tape such that the remaining protrusion (L) does not exceed a maximum of 11 mm.
3. Component lead to tape adhesion must meet the pull test requirements.
4. Maximum non-cumulative variation between tape feed holes shall not exceed 1 mm in 20 pitches.
5. Holddown tape not to extend beyond the edge(s) of carrier tape and there shall be no exposure of adhesive.
6. No more than 1 consecutive missing component is permitted.
7. A tape trailer and leader, having at least three feed holes is required before the first and after the last component.
8. Splices will not interfere with the sprocket feed holes.

2N6027, 2N6028

ORDERING & SHIPPING INFORMATION: 2N6027 and 2N6028 packaging options, Device Suffix

U.S.	Europe Equivalent	Shipping	Description of TO92 Tape Orientation
2N6027, 2N6028 2N6027, 2N6028RLRA 2N6028RLRM 2N6028RLRP	2N6027RL1	Bulk in Box (5K/Box) Radial Tape and Reel (2K/Reel) Radial Tape and Reel (2K/Reel) Radial Tape and Fan Fold Box (2K/Box) Radial Tape and Fan Fold Box (2K/Box)	N/A, Bulk Round side of TO92 and adhesive tape visible Flat side of TO92 and adhesive tape visible Flat side of TO92 and adhesive tape visible Round side of TO92 and adhesive tape visible