

### 0395

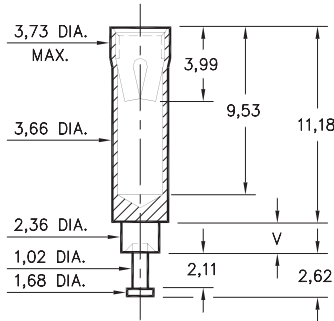

**0395-X-15-XX-07-XX-10-0**  
Swage mount in 2,44 hole

Basic Part Number	Board Thickness	Length V
0395-1	0,79	1,57
0395-2	1,57	2,39
0395-3	2,39	3,18
0395-4	3,18	3,96
0395-5	4,78	5,56

### 8016

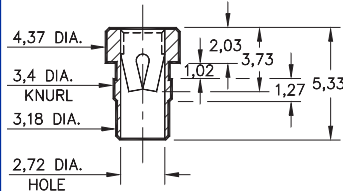

**8016-0-15-XX-07-XX-10-0**  
Press-fit in 3,33 mounting hole

### 0350

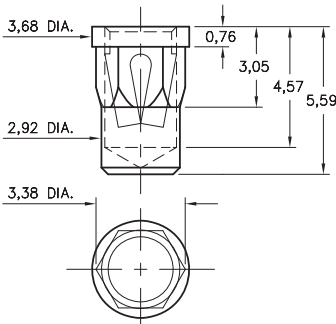

**0350-0-15-XX-07-XX-10-0**  
Hex press-fit in 3,28±0,05 plated thru hole

### 8837

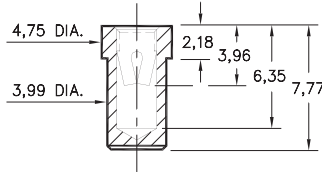

**8837-0-15-XX-14-XX-10-0**  
Solder mount in 4,04 min. mounting hole

#### SPECIFICATIONS

**SHELL MATERIAL:**  
Brass Alloy 360, 1/2 Hard

**CONTACT MATERIAL:**  
Beryllium Copper Alloy 172, HT

**DIMENSION IN INCHES TOLERANCES ON:**  
LENGTHS: ±0,13  
DIAMETERS: ±0,05  
ANGLES: ± 2°

**ORDER CODE: XXXX - X - 15 - XX - XX - XX - 10 - 0**

**BASIC PART #** →

- SPECIFY SHELL FINISH:**
- 01 5,08µm TIN/LEAD OVER NICKEL
  - ◇ 80 5,08µm TIN OVER NICKEL (RoHS)
  - ◇ 15 0,25µm GOLD OVER NICKEL (RoHS)

- SPECIFY CONTACT FINISH:**
- 01 5,08µm TIN/LEAD OVER NICKEL
  - ◇ 80 5,08µm TIN OVER NICKEL (RoHS)
  - ◇ 27 0,76µm GOLD OVER NICKEL (RoHS)



**SELECT CONTACT**

#07 or #14 CONTACT (DATA ON PAGES 225 & 226)