

## Single Phase Hall Effect Latch

### ■ Features

- 2.2V to 20V DC operation voltage
- Temperature compensation
- Wide operating voltage range
- Open drain pre-driver
- 25mA maximum sinking output current
- Package: SIP3, SOT23

### ■ Applications

- Brush-less DC Motor
- Brush-less DC Fan
- Revolution counting
- Speed measurement

### ■ Pin Assignments

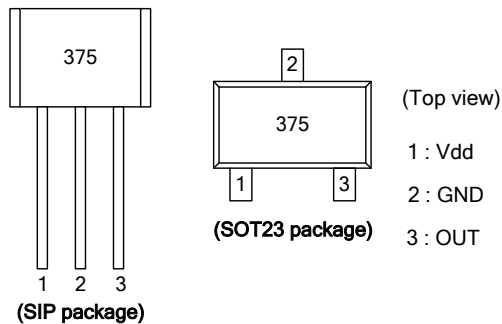

### ■ General Description

AH375 is an integrated Hall effect latched sensor designed for electronic commutation of brush-less DC motor applications. The device includes an on-chip Hall voltage generator for magnetic sensing, a comparator that amplifies the Hall voltage, and a schmitt trigger to provide switching hysteresis for noise rejection, and open drain output. An internal bandgap regulator is used to provide temperature compensated supply voltage for internal circuits and allows a wide operating supply range. If a magnetic flux density larger than threshold Bop, DO is turned on(low). The output state is held until a magnetic flux density reversal falls below Brp causing DO to be turned off (high).

### ■ Pin Descriptions

Name	P/I/O	Pin #	Description
Vdd	P	1	Positive Power Supply
GND	P	2	Ground
OUT	O	3	Output Pin

### ■ Ordering Information

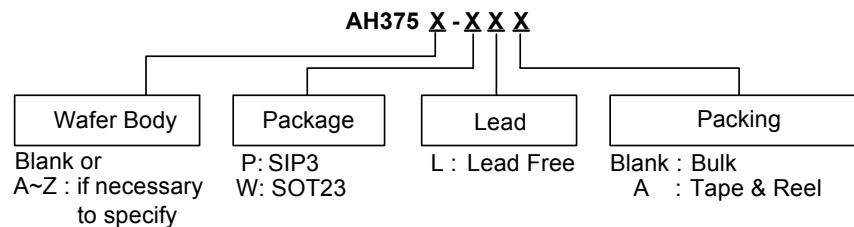

## Single Phase Hall Effect Latch

### ■ Typical Application Circuit

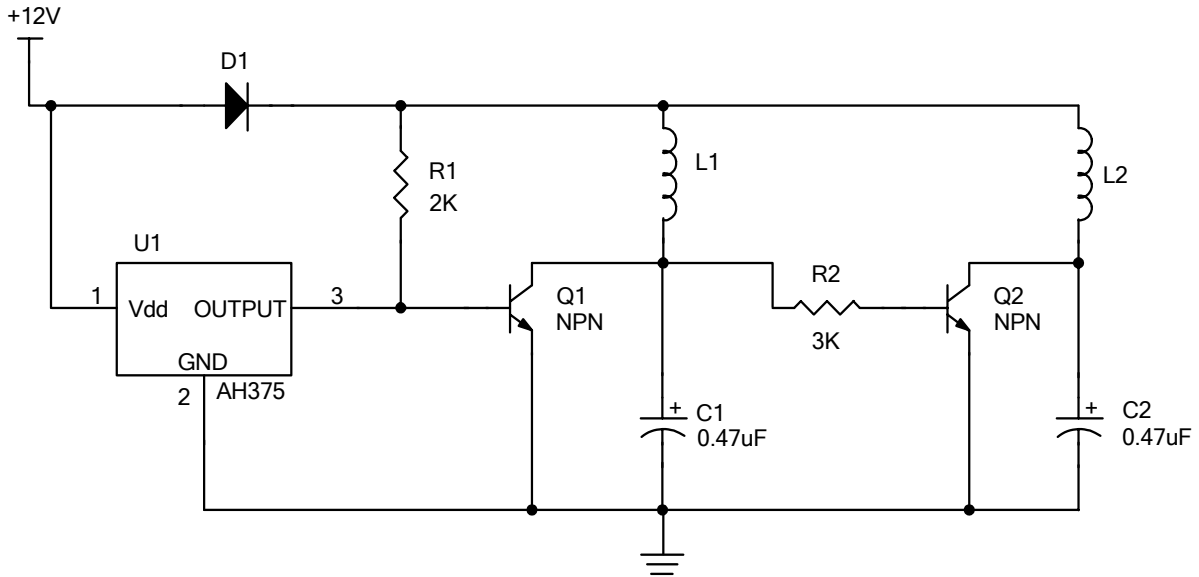

Brush-less DC Fan

### ■ Functional Block Diagrams

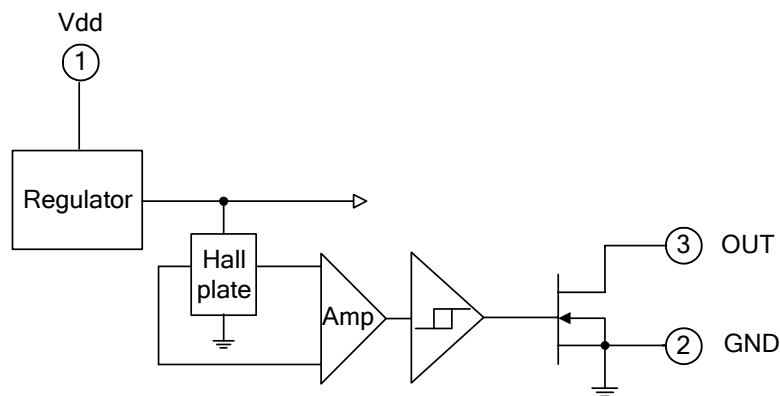

## Single Phase Hall Effect Latch

### ■ Absolute Maximum Ratings ( at Ta=25°C )

Characteristics		Symbol	Values	Unit
Supply Voltage		Vdd	20	V
Magnetic Flux Density		B	Unlimited	
Output OFF Voltage		V <sub>DS</sub>	30	V
Output "On" Current	Continuous	I <sub>d</sub>	25	mA
Operating Temperature Range		T <sub>a</sub>	-40~+125	°C
Storage Temperature Range		T <sub>s</sub>	-65~+150	°C
Maximum Junction Temp.		T <sub>j</sub>	150	°C
Package Power Dissipation	SIP-3L	P <sub>d</sub>	550	mW
	SOT23-3L		230	mW
Thermal Resistance	SIP-3L	θ <sub>jc</sub>	227	°C/W
	SOT23-3L		543	

### ■ Electrical Characteristics (Ta=+ 25°C, Vdd =12V)

Characteristic	Symbol	Test Conditions	Min	Typ	Max	Units
Supply Voltage	Vdd	—	2.2	-	20	V
Output Saturation Voltage	V <sub>ds(sat)</sub>	I <sub>out</sub> =20mA	-	300	700	mV
Output Leakage Current	I <sub>off</sub>	V <sub>DD</sub> =14V	-	<0.1	10	uA
Supply Current	I <sub>dd</sub>	Output Open	-	2	4	mA
Output Rise Time	t <sub>r</sub>	R <sub>L</sub> =820Ω, C <sub>L</sub> =20Pf	-	0.1	1	us
Output Falling Time	t <sub>f</sub>	R <sub>L</sub> =820Ω, C <sub>L</sub> =20pF	-	0.1	1	us

### ■ Test Circuit

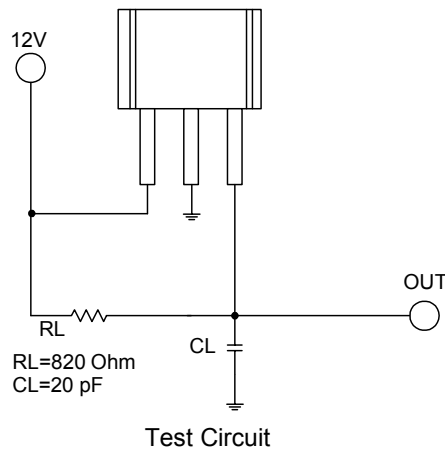

### ■ Magnetic Characteristics (Ta=25°C, Vdd =2.5V to 20V)

(1mT=10Gauss)

Parameter	Symbol	Min.	Typ.	Max.	Unit
Operate Point	B <sub>op</sub>	5	30	60	Gauss
Release Point	B <sub>rp</sub>	-60	-30	-5	Gauss
Hysteresis	B <sub>hys</sub>	-	60	-	Gauss

## Single Phase Hall Effect Latch

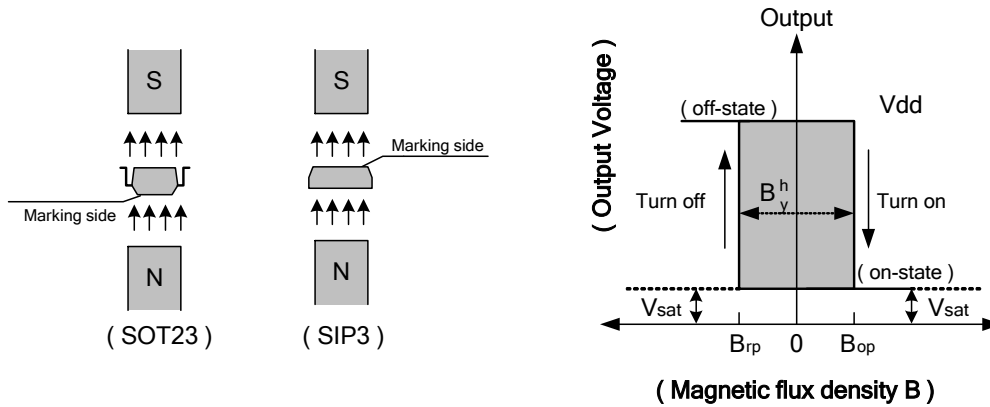

### ■ Performance Characteristics (SIP3)

<b>Ta (°C)</b>	<b>25</b>	<b>50</b>	<b>60</b>	<b>70</b>	<b>80</b>	<b>85</b>	<b>90</b>	<b>95</b>	<b>100</b>
Pd (mW)	550	440	396	352	308	286	264	242	220
<b>Ta (°C)</b>	<b>105</b>	<b>110</b>	<b>115</b>	<b>120</b>	<b>125</b>	<b>130</b>	<b>135</b>	<b>140</b>	<b>150</b>
Pd (mW)	198	176	154	132	110	88	66	44	0

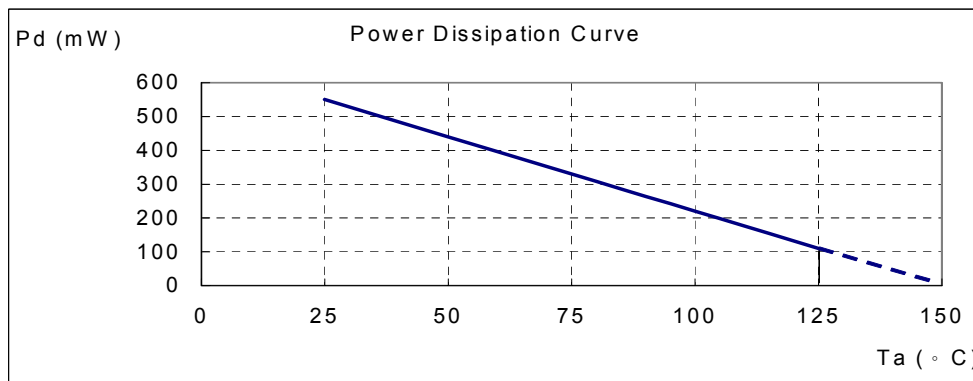

### ■ Performance Characteristics (SOT23-3)

<b>Ta (°C)</b>	<b>25</b>	<b>50</b>	<b>60</b>	<b>70</b>	<b>80</b>	<b>90</b>	<b>100</b>	<b>110</b>	<b>120</b>	<b>125</b>	<b>130</b>	<b>140</b>	<b>150</b>
Pd (mW)	230	184	166	147	129	110	92	74	55	46	37	18	0

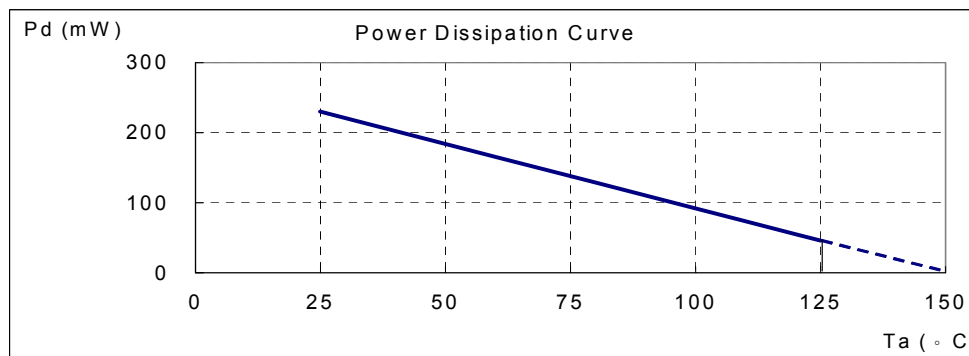

## Single Phase Hall Effect Latch

### ■ Marking Information

#### (1) SIP3

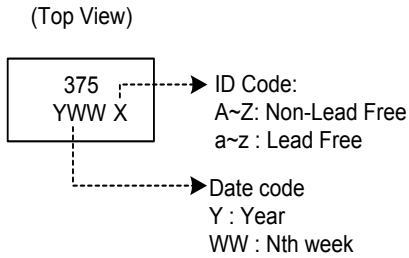

#### (2) SOT23

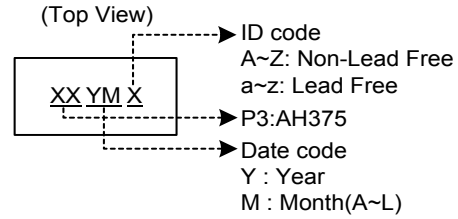

### ■ Package Information (unit: mm)

#### (1) Package Type: SIP-3L

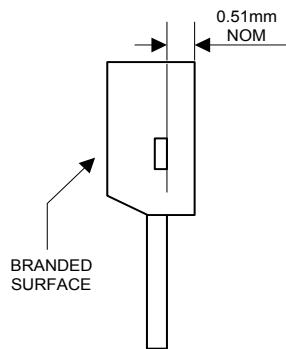

Active Area Depth

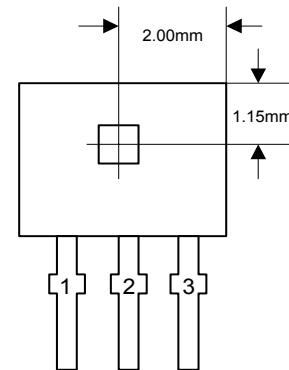

Sensor Location

#### Package Dimension

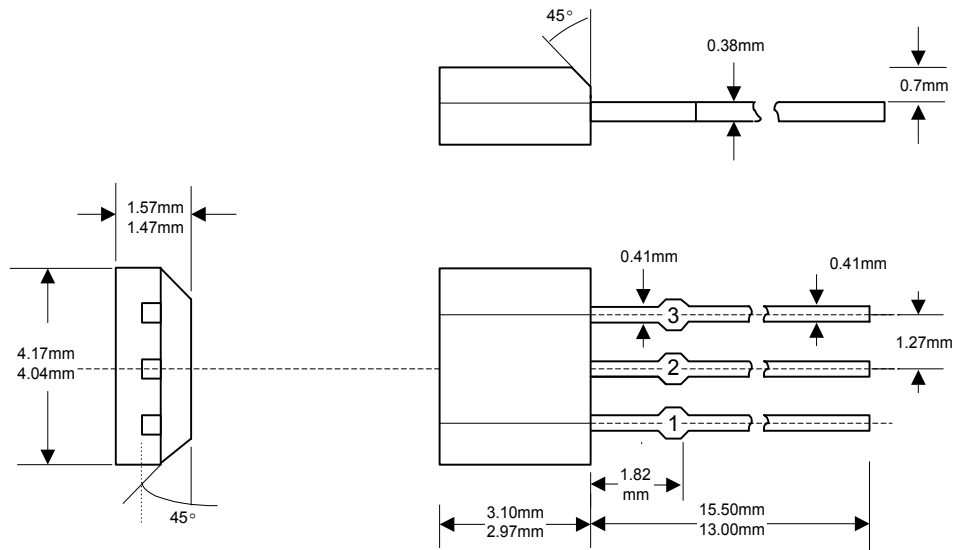

## Single Phase Hall Effect Latch

### ■ Package Information (Continued)

(2) Package Type: SOT23-3L

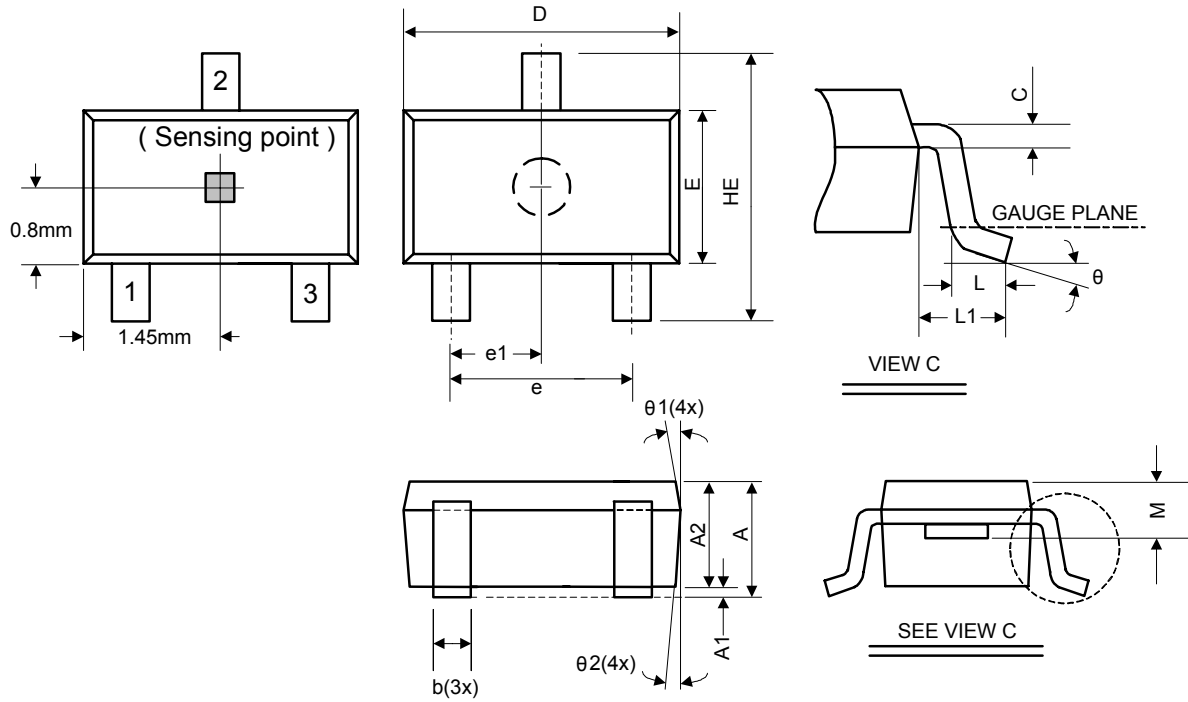

Symbol	Dimensions In Millimeters			Dimensions In Inches		
	Min.	Nom.	Max.	Min.	Nom.	Max.
A	1.05	-	1.35	0.041	-	0.053
A1	0.05	-	0.15	0.002	-	0.006
A2	1.00	1.10	1.20	0.039	0.043	0.047
b	0.25	-	0.50	0.010	-	0.020
C	0.08	-	0.20	0.003	-	0.008
D	2.70	2.90	3.00	0.106	0.114	0.118
E	1.50	1.60	1.70	0.059	0.063	0.067
HE	2.60	2.80	3.00	0.102	0.110	0.118
L	0.30	-	0.60	0.012	-	0.024
L1	0.50	0.60	0.70	0.020	0.024	0.028
M	0.73	0.78	0.83	0.029	0.031	0.033
e	1.80	1.90	2.00	0.071	0.075	0.079
e1	0.85	0.95	1.05	0.033	0.037	0.041
theta	0°	5°	10°	0°	5°	10°
theta1	3°	5°	7°	3°	5°	7°
theta2	6°	8°	10°	6°	8°	10°