



Bluetooth RS232 Serial Adapter Manual

Document Version: 1.3
Firmware Version: 6.5x



LM048



LM058



Document History

Revision	Date	Name	Description
1.0	25-03-2011	SV	Initial version
1.1	16-05-2011	PM	Add CE Certificates
1.2	15-02-2012	SV	1. Add LM058 Hardware Structure 2. Update LM149 Configuration Software screenshot
1.3	14-05-2013	SV	Added FCC Regulation Statement

Table of contents

1	Introduction	Page 1
2	Features	Page 1
3	Package	Page 2
4	General Specification	Page 2
5	RS232 Interface	Page 3
5.1	Pin-out	Page 3
5.2	Signals	Page 3
5.3	Factory Settings	Page 3
6	Installation	Page 4
6.1	LM048 Hardware Structure	Page 4
6.2	LM058 Hardware Structure	Page 4
6.3	Reset Button	Page 5
6.4	Slide Switch	Page 5
6.5	Power Supply	Page 5
6.6	Antenna Connector (LM058 only)	Page 5
6.7	LED Status	Page 5
6.8	Installation Procedure	Page 6
7	Usage	Page 6
7.1	Hyperterminal Settings	Page 6
7.2	Configuration Setup	Page 6
7.3	Master Role Configuration	Page 7
7.4	Configure Master Slave adapter pair	Page 7
7.5	3 wire configuration	Page 7
7.6	5 wire configuration	Page 7
7.7	7 wire configuration	Page 7
7.8	AT Command Set	Page 7
7.9	Modem Signal Settings	Page 12
8	Windows Configuration Software	Page 13
9	Warranty and Disposal Notice	Page 15
10	FCC Regulation Statement	Page 16
	LM048 CE Certificate	Page 18
	LM058 CE Certificate	Page 19

1. Introduction

Welcome to the LM Technologies Bluetooth RS232 Serial adapter. The LM048/LM058 adapter eliminates your conventional RS232 serial cables, providing an easy-to-use, invisible connection with superior freedom of movement. This adapter allows any device with a standard 9-pin serial port to communicate wirelessly.

This adapter can use both RTS/CTS flow control or DTR/DSR handshaking. This adapter is capable emulating a serial cable in true sense by transferring all the RS232 controls signals (RTS, CTS, DTR and DSR) wirelessly to the remote side over a bluetooth link. This capability is beneficial in case of Serial Printers which report error conditions like “Out of Paper”, “Power failure” etc by de-asserting the DTR or RTS lines.

This adapter is mostly used in pairs as serial cable replacement. However, you can communicate with another Bluetooth serial adapter or other Bluetooth enabled devices such as a laptop computer, PDA or mobile phone.

2 Features

- Supports Bluetooth Serial port profile and Generic Access profile
- No need of external host and software
- Ease of installation, maintenance and use
- Supports configuration of local device
- Supports up to 100 meters (open space)
- Support of RTS/CTS data flow control
- Support of DTR/DSR handshaking
- Ability to transfer RTS, CTS, DTR and DSR signals wirelessly over bluetooth link. This unique signal handling feature is used in reporting messages such as “Out of Paper” or “Off Line” from a Serial Printer back to the PC or Terminal equipment
- Certified by leading Serial Printer Manufacturers like Casio, Star Micronics and Casio
- Supports External SMA Antenna (LM058 only)

3. Package

Bluetooth serial adapter
DB9 male to female converter
USB cable for power supply
User manual
Warranty Card
2Dbi Antenna (LM058 only)
Optional:
9 pin to 25 pin converter
All in one power supply (UK, EU and US Plug)

4. General Specification

Specification	Description
Baud Rate	1.2/2.4/4.8/9.6/19.2/38.4/57.6/115.2/230.4/460.8/921.6 Kbps
Coverage	Up to 100 Meters
Connection	Point-to-Point (piconet)
Signal	TxD, RxD, GND, RTS, CTS, DTR, DSR
RS-232 Interface	D_SUB 9-pin female
Standard Bluetooth	v2.0+EDR. v2.1 +EDR firmware also available
Frequency	2.400 to 2.4835 GHz
Hopping	1,600/sec, 1MHz channel space
Modulation	GFSK-1 Mbps, DQPSK-2 Mbps, and 8-DPSK-3 Mbps
Tx. power	Max. 18 dBm (Class 1)
Rx. Sensitivity	-86 dBm typical
Antenna	Chip antenna
Antenna Gain	Max. 1 to 2 dBi
Power Supply	+4 to +12 V DC
Current Consumption	Max. 90 mA
Operation Temperature	-20°C to +75°C

Dimensions	LM048: 46.3 mm (W) x 34 mm (D) x 16 mm (H) LM058: 35 mm (W) x 65 mm (D) x 16 mm (H)
------------	--

5 RS232 Interface

5.1 Pin-out

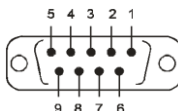

5.2 Signals

Pin	DTE Signal	DTE to DCE Direction	DCE to DTE Direction	Description
1	CD	Input	Output	Not connected
2	RxD	Input	Output	Received data
3	TxD	Output	Input	Transmitted data
4	DTR	Output	Input	Data Terminal Ready
5	GND	N/A	N/A	Signal ground
6	DSR	Input	Output	Data Set Ready
7	RTS	Output	Input	Request to Send
8	CTS	Input	Output	Clear to Send
9	Vcc	Input	Input	Power supply

5.3. Factory Settings

The factory settings of COM port are as follows: Baud rate: 19200 bps

Data bit: 8

Parity: none

Stop bit: 1

Flow control: None

Others: please refer to section 7.8 AT Command Set.

6 Installation

6.1 LM048 Hardware Structure

The figure below is an outline of the adapter.

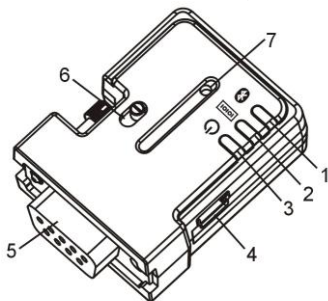

1. Link LED	2. Data LED	3. Power LED	4. Mini USB connector
5. RS232 connector	6. Slide Switch	7. Reset Button	

6.2 LM058 Hardware Structure

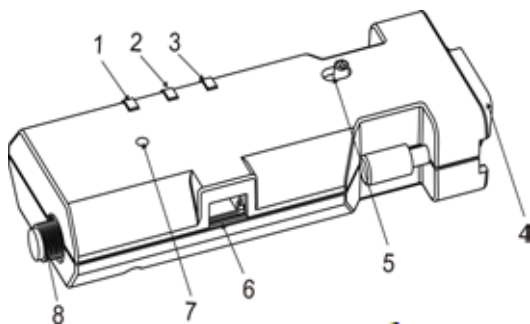

1. Power LED	2. Data LED	3. Link LED	4. RS232 connector
5. Slide Switch	6. Mini USB Connector	7. Reset Button	8. Antenna Connector

6.3 Reset Button

By pressing the Reset button, you can:
Disconnect and reconnect a wireless connection (after a short press). Restore the factory settings (after over three seconds' press).

6.4 Slide Switch

The slide switch can swap TXD/RXD, RTS/CTS and DTR/DSR signals. Using this switch, you can set the adapter either as a DTE (towards antenna connector) or a DCE (towards RS232 connector).

6.5 Power Supply

The adapter can be powered via:
An AC/DC converter (output power: +5 to +12 V DC/300 mA)
A mini- USB cable
Pin 9 of the RS232 DB9 connector

6.6 Antenna Connector (LM058 only)

The LM058 has a Reverse Polarity (RP) SMA Antenna Connector to connect the 2dBi antenna provided with it. User can also connect a high gain antenna instead of 2 dBi antenna to increase the range.

6.7 LED Status

The following is LED status information.

Status	Description
All LED on/off three times	Device boot OK.
Data LED on	Transmitting/Receiving data.
Link LED off	No pairing established.
Link LED fast (0.1 sec) blinking	Pairing
Link LED fast (0.3 sec) blinking	Discoverable and waiting for a connection (slave mode)
Link LED slow (0.9 sec) blinking	Inquiring (master mode).
Link LED very slow (1.2 sec) blinking	Connecting (master mode).
Link LED steadily on	Connection established.

6.8 Installation Procedure

Step 1: Plug the adapter into the COM port of device.

Step 2: Adjust the slide switch, depending on whether the device is a DCE or DTE.

Step 3: Power the adapter on.

Step 4: Configure the adapter using LM149 Software if necessary.

Note: The UART settings on adapter should match the COM Port settings on the device.

7 Usage

You can reprogram the adapter settings using HyperTerminal.

7.1 HyperTerminal Settings

Bits per second: 19200 bps (baud rate)

Data bit: 8

Parity: None

Stop bit: 1

Flow control: None

7.2 Configuration Start-up

Step 1: Plug the adapter into a COM port of PC.

Step 2: Power the adapter on.

Step 3: Create a HyperTerminal file.

Step 4: On the interface of the new Hyper Terminal file, click **Properties Button**.

Step 5: Select the COM port where the adapter is attached to your PC and set the port properties as described in section 7.1 Hyper Terminal Settings.

Step 6: Input "A" in the file.

If no echo, that is, nothing is displayed when you input "A", it indicates that the COM port settings are incorrect or slide switch is in the wrong position.

Step 7: Input "AT", and then press <Enter>. "OK" is displayed.

If necessary, reprogram the configuration of adapter using AT commands. For related commands, please refer to section 7.8 AT Command Set.

7.3 Master Role Configuration

You can use “AT+ROLEM” to change the adapter to the master role. When the adapter is in the master role, you can use “AT+ACON-” to manually set up a connection and “AT+FIND?” to find the device you want to connect.

7.4 Configure Master-Slave adapter pair

Please refer to configuration utility software (Section 8) to configure a master slave adapter pair. Once the configuration is done, the pair will connect to each other automatically.

7.5 3 wire configuration

The default configuration is the 3 wire configuration in which only Tx, Rx and GND lines are used. Set the 3 wire configuration by sending AT+FLOW- and AT+MODEM- command.

7.6 5 wire configuration (Tx, Rx, GND, RTS, CTS)

Set 5 wire configuration which uses RTS, CTS flow control signals by sending AT+FLOW+ and AT+MODEM- command. RTS, CTS status is not transferred wirelessly over Bluetooth link to the remote side.

7.7 7 wire configuration (Tx, Rx, GND, RTS, CTS, DTR, DSR)

Set 7 wire configuration by sending AT+FLOW+ and AT+MODEMR command. RTS, CTS lines are used for local flow control between device and adapter. DTR, DSR lines are used for handshaking between local device and remote connected device. The DTR, DSR line status is transmitted wirelessly over bluetooth link
For all settings refer section 7.9

7.8 AT Command Set

The following is the AT command set for the local adapter in the command mode (that is, the local adapter is in the disconnection state). All the commands and parameters are case insensitive. Please note “AT+FIND?” command is available only when the adapter is in the manual master role. In other words, you should send “AT+ROLEM”, “AT+ACON-” before sending “AT+FIND?” command“

Command	Description
+++	Switch the device from online Data mode to online command mode while maintaining the connection to the remote device. The characters should be send with 1000 ms guard time..
AT	Check the serial port communication with the adapter
AT+VER	Inquire the current firmware version
AT+ENQ	Lists all the settings along with their brief description. The settings include serial port, Bluetooth related and other misc settings
AT+ACON	Enable/disable auto-connection feature in master role. Note: This command will cause a reboot.
ACON+ (default)	Automatically connect to the adapter specified in AT+BOND=xxxxxxx. If no device is specified then connect to any device which is ready to accept connection.
ACON-	Disable auto-connection feature. After it is executed, you need to execute "AT+CONN" to manually connect a remote device
ACON?	Inquire the current setting
AT+CONN	Establish a connection. It is available only when the adapter is in the manual master role.
AT+CONN	Connect to the specified bonded device. It is available only when AT+BOND=xxxxxxxxxx is executed where "xxxxxxxxxxxx" is the 12 hex digit string specifying remote device bluetooth address.
AT+CONN=xxxxxxxxxxxx	Connect the adapter to a specified Bluetooth device. "xxxxxxxxxxxx" is 12 hexadecimal digit string specifying Remote device Bluetooth address
AT+CONNn (n=1-8)	Connect the adapter to a device in the neighborhood found through "AT+FIND?". N is the index of the discovered Bluetooth device during inquiry
AT+DROP	Drop the connection when the device is in either master or slave role. It is only allowed when the device is in connected state
AT+ADDR	
AT+ADDR?	Inquire the Bluetooth address of the local adapter.

AT+BOND	For security purpose, this command is used to specify a unique remote Bluetooth serial adapter to be connected. In the master role, the adapter pairs and connects with the designated remote slave address. In the slave mode, this command is a filter condition to accept the inquiry of the master device.
AT+BOND=xxxxxxxxxxx	“xxxxxxxxxxx” is a string of 12 hexadecimal digits specifying the slave Bluetooth Device address.
AT+BOND-	Restore the status in which the adapter can connect with any remote address.
AT+BOND?	Inquire the designated address that can be paired and connected.
AT+FIND	Search for any Bluetooth device in the neighborhood within one minute. If any device is found, its name and address will be listed. The search ends with a message “Inquiry ends. xx device(s) found.” This command is available only when the adapter is in the manual master role.
AT+FIND?	Start the inquiry
AT+FIND-	Cancel the ongoing inquiry
AT+ROLE	Specify whether the adapter is in the master or slave role. If the device role is changed, the adapter will reboot and all paired records will be cleared.
AT+ROLEM	Set the adapter to the master role.
AT+ROLES (default)	Set the adapter to the slave role.
AT+ROLE?	Inquire the current role of the adapter.
AT+NAME	Specify a name for the adapter. You can specify a friendly name using 0 to 9, A to Z, a to z, space and -, which are all valid characters. Note that “first space or -, last space or - isn’t permitted”. The default name is “SerialADT”.
AT+NAME=xxxxx	“xxxxx” is a character string with a maximal length of 16.
AT+NAME?	Inquire the name of the local adapter.
AT+PIN	Specify a PIN. The default PIN is “1234”. Paired adapters should have a same PIN.
AT+PIN=xxxx	“xxxx” is a 4-8 digit string.
AT+PIN-	Cancel authentication by PIN.
AT+PIN?	Inquire the current PIN.
AT+RCFG	Enables/disable remote configuration from a remote device by executing the remote access handshaking
AT+RCFG+	Enables remote configuration.
AT+RCFG- (default)	Disables remote configuration.
AT+RCFG?	Inquire the current setting

AT+DCOV	Specify whether the adapter can be discovered by remote device. Changing this value causes a reboot.
AT+DCOV+ (default)	Device is in discoverable state.
AT+DCOV-	Device is non discoverable.
AT+DCOV?	Inquire the current discoverability status.
AT+RESP	Specify whether result messages are prompted when AT commands are executed. The result messages are: OK/ERROR for command execution, or CONNECT/DISCONNECT for connection status.
AT+RESP+ (default)	Prompt result messages.
AT+RESP-	Not prompt result messages.
AT+RESP?	Inquire the current setting.
AT+FLOW	Enables or disables RTS/CTS signals handshaking of the UART port. Note, the setting will cause a reboot
AT+FLOW- (default)	Disable RTS/CTS flow control
AT+FLOW+	Enable RTS/CTS flow control
AT+FLOW?	Inquire the current setting
AT+BAUD	Specify the baud rate of COM port.
AT+BAUD10	1200 bps
AT+BAUD11	2400 bps
AT+BAUD12	4800 bps
AT+BAUD13	9600 bps
AT+BAUD14 (default)	19200 bps
AT+BAUD15	38400 bps
AT+BAUD16	57600 bps
AT+BAUD17	115200 bps
AT+BAUD18	230.4 Kbps
AT+BAUD19	460.8 Kbps
AT+BAUD20	921.6 Kbps
AT+BAUD?	Inquire the current baud rate.
AT+PAR	Specify parity bit setting of COM port.
AT+PAR0(default)	None parity bit.
AT+PAR1	Odd parity.
AT+PAR2	Even parity
AT+PAR?	Inquire the current setting.

AT+SLEEP	Enable/disable auto-power saving feature of adapter
AT+SLEEP- (default)	Disable auto power saving
AT+SLEEP+	Enable auto power saving
AT+SLEEP?	Inquire the current setting.
AT+STOP	Specify one or two stop bits of COM port.
AT+STOP1(default)	One stop bit.
AT+STOP2	Two stop bits.
AT+STOP?	Inquire the current setting.
AT+ESC	Disable/Enable escape sequence “+++” handling.
AT+ESC-	Disable escape sequence handling.
AT+ESC+ (default)	Enable escape sequence handling.
AT+ESC?	Inquire the current setting.
AT+ECHO	Enable/disable echo of command characters from bluetooth device.
AT+ECHO-	Disable echo
AT+ECHO+ (default)	Enable echo
AT+ECHO?	Inquire the current setting
AT+RSSI	Inquire the RSSI value for current bluetooth connection. This command is only available when the device is in connected state.
AT+MODEM	Enable/disable RS232 modem signals. This command is used in conjunction with AT+FLOW command
AT+MODEM- (default)	Disable Modem Signals
AT+MODEML	Enable Local loopback. RS232 signals are looped back with each other, depending on flow control setting
AT+MODEMR	Enable Remote transfer. RS232 signals will be transferred over bluetooth link depending on flow control setting
AT+MODEM?	Inquire the current setting
AT+RESET	Restore the default settings and reboot.

7.9 Modem Signal Settings

The modem signal setting is used in conjunction with AT+FLOW setting to enable/disable RS232 control signals as per the table below.

FLOW CONTROL (AT+FLOW)	MODEM SIGNAL (AT+MODEM)	RS232 SIGNALS	Description
FLOW-	MODEM-	Tx, Rx, GND	3 wire configuration
FLOW+	MODEM-	Tx, Rx, GND, RTS, CTS	RTS CTS signals are used for data flow control between host and adapter, and NOT transferred to remote side wirelessly.
FLOW-	MODEML	Tx, Rx, GND, RTS<->CTS, DTR<->DSR	RTS looped back to CTS, DTR looped back to DSR
FLOW+	MODEML	Tx, Rx, GND, RTS, CTS, DTR<->DSR	RTS CTS signals used for data flow control between host and adapter, and NOT transferred to remote side wirelessly. DTR looped back to DSR. This configuration is equivalent to LM048 adapter running v4.5x firmware.
FLOW-	MODEMR	Tx, Rx, GND, RTS(R), CTS(R), DTR(R), DSR(R)	All 7 signals used. All RS232 control signals (DTR, DSR, RTS and CTS) transferred wirelessly to remote side.

FLOW+	MODEMR	Tx, Rx, GND, RTS, CTS, DTR(R), DSR(R)	All 7 lines used. Only DTR, DSR signals transferred wirelessly to remote side. If RTS, CTS signals are not used, then this configuration is equivalent to LM048 SPA Adapter running v4.6X firmware.
-------	--------	---	--

8. Windows configuration software

The [LM149 Configuration Software](#) allows easy setup of LM048/LM058 RS232 Bluetooth serial adapters.

To start the configuration software click “Read Settings” or “Get Device Info” in order to view current settings of LM048/LM058 adapter. Once you have setup the configuration that you require you will then need to click “Save Settings” or “Program Device”.

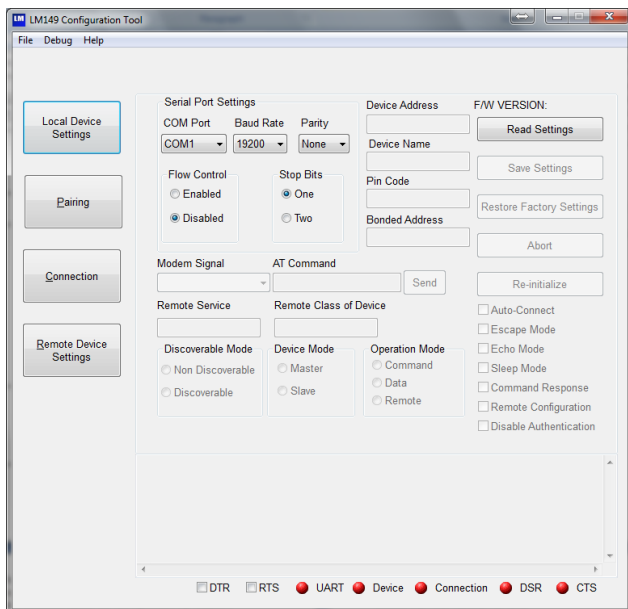

The LM048/LM058 can also be paired via the configuration program using the “Pairing” button. It takes you to the page which provides option for Pairing/Unpairing adapters.

If you want to set the adapter back to the factory default settings please click the “Restore Factory Settings” button.

9. Warranty and Disposal Notice

One (1) Year International warranty

Your LM Technologies LM048/LM058 is warranted by your supplier for a period of one (1) year from the original date of purchase under the terms and conditions of this warranty. This warranty covers materials and manufacturing defects. Your supplier will require proof of purchase before replacing the defective product.



Important Notice

DISPOSAL OF OLD ELECTRICAL AND ELECTRONIC EQUIPMENT

The symbol indicates that this product shall not be mixed with unsorted municipal waste when disposed of. There is separate collection system for waste electrical and electronic equipment. Usually old electrical and electronic equipment can be returned free of charge. For further information please contact the competent municipal authorities or shop where you purchased the product. Correct disposal ensures that waste electrical and electronic Equipment is recycled and reused appropriately. It helps avoid potential damage for the environment and human health and to preserve natural resources.

10. FCC Regulation Statement

This device complies with Part 15 of the FCC Rules. Operation is subject to the following two conditions:

- 1) This device may not cause harmful interference, and
- 2) This device must accept any interference received, including interference that may cause undesired operation

This equipment has been tested and found to comply with the limits for a class B digital device, pursuant to part 15 of the FCC Rules. These limits are designed to provide reasonable protection against harmful interference in a residential installation. This equipment generates, uses and can radiate radio frequency energy and, if not installed and used in accordance with the instructions, may cause harmful interference to radio communications. However, there is no guarantee that interference will not occur in a particular installation. If this equipment does cause harmful interference to radio or television reception, which can be determined by turning the equipment off and on, the user is encouraged to try to correct the interference by one or more of the following measures:

- Reorient or relocate the receiving antenna.
- Increase the separation between the equipment and receiver.
- Connect the equipment into an outlet on a circuit different from that to which the receiver is connected.
- Consult the dealer or an experienced radio/TV technician for help.

Installation and use of this device must be in strict accordance with the instructions included in the user documentation provided with the product. Any changes or modifications (including the antennas) made to this device that are not expressly approved by the manufacturer may void the user's authority to operate the equipment. The manufacturer is not responsible for any radio or television interference caused by unauthorized modification of this device, or the substitution of the connecting cables and equipment other than manufacturer specified. It is the responsibility of the user to correct any interference caused by such unauthorized modification, substitution or attachment.

Manufacturer and its authorized resellers or distributors will assume no liability for any damage or violation of government regulations arising from failing to comply with these guidelines. This equipment complies with FCC radiation exposure limits set forth for an uncontrolled environment. This transmitter must not be co-located or operating in conjunction with any other antenna or transmitter.

EU Declaration of Conformity (RTTE)

LM Technologies, 26 D Guosheng Tai, Guozhan block, Buji Town, Shenzhen, China.

(Factory name, address)

Declare under our sole responsibility that the product

Bluetooth RS232 Adapter (LM048)

To which this declaration relates is in conformity with

RTTE Directive 1999/5/EC (Annex II)
Low Voltage Directive 73/23/EEC-93/68/EEC
EMC Directive 89/336/EEC-92/31/EEC
By application of the following standards



EN 300 328	November 2004	V1.6.1
EN 301 489-1	August 2002	V1.4.1
EN 301 489-17	August 2003	V1.2.1
EN 609 950-1	2001	
EN 50371	14 June 2002	

(Manufacturer)

LM Technologies,
26D Guosheng tai,
Guozhan block,
Buji Town, Shenzhen,
China.

08/01/2008

(Place and date of issue)

Mr Lee Parry / Director

(name and signature of authorized person)

(Representative in the EU)

LM Technologies Ltd
Unit 10, Caroline Point,
82 Caroline Street,
Birmingham, B3 1 UF,
UK

08/01/2008

(place and date of issue)

Mr Lee Parry / Director

(name and signature of authorized person)

Copyright © LM Technologies Ltd - 2013

