



32M(2Mx16) Low Power SDRAM

Revision 0.2

January, 2007

Document Title

32M(2Mx16) Low Power SDRAM

Revision History

Revision No.	History	Draft date	Remark
0.0	Initial Draft	Mar.3 rd , 2005	Preliminary
0.1	Add H(Pb-Free & Halogen Free) descriptions	Nov. 1 st , 2005	Final
0.2	Corrected Typo.	Jan. 3 rd , 2007	Final

Features

- **Functionality**
 - Standard SDRAM Functionality
 - Programmable burst lengths : 1, 2, 4, 8, or full page
 - JEDEC Compatibility
- **Low Power Features**
 - Low voltage power supply : 2.5V/3.0V
 - Auto TCSR(Temperature Compensated Self Refresh)
 - Partial Array Self Refresh power-saving mode
 - Deep Power Down Mode
 - Driver Strength Control
- **Operating Temperature Ranges:**
 - Special (-10°C to +60°C)
 - Commercial (0°C to +70°C)
 - Extended (-25°C to +85°C)
 - Industrial (-40°C to +85°C)

- **LVC MOS Compatible IO Interface**
- **54ball FBGA with 0.8mm ball pitch**
 - CMS3216LAF : Normal
 - CMS3216LAG : Pb-Free
 - CMS3216LAH : Pb-Free & Halogen Free

Functional Description

The CMS3216LAX-xxxx family is high-performance CMOS Dynamic RAMs (DRAM) organized as 2M x 16. These devices feature advanced circuit design to provide ultra-low active current and extremely low standby current. This is ideal for providing More Battery Life in portable applications such as wireless handsets. The device is compatible with the JEDEC standard LP-SDRAM specifications.

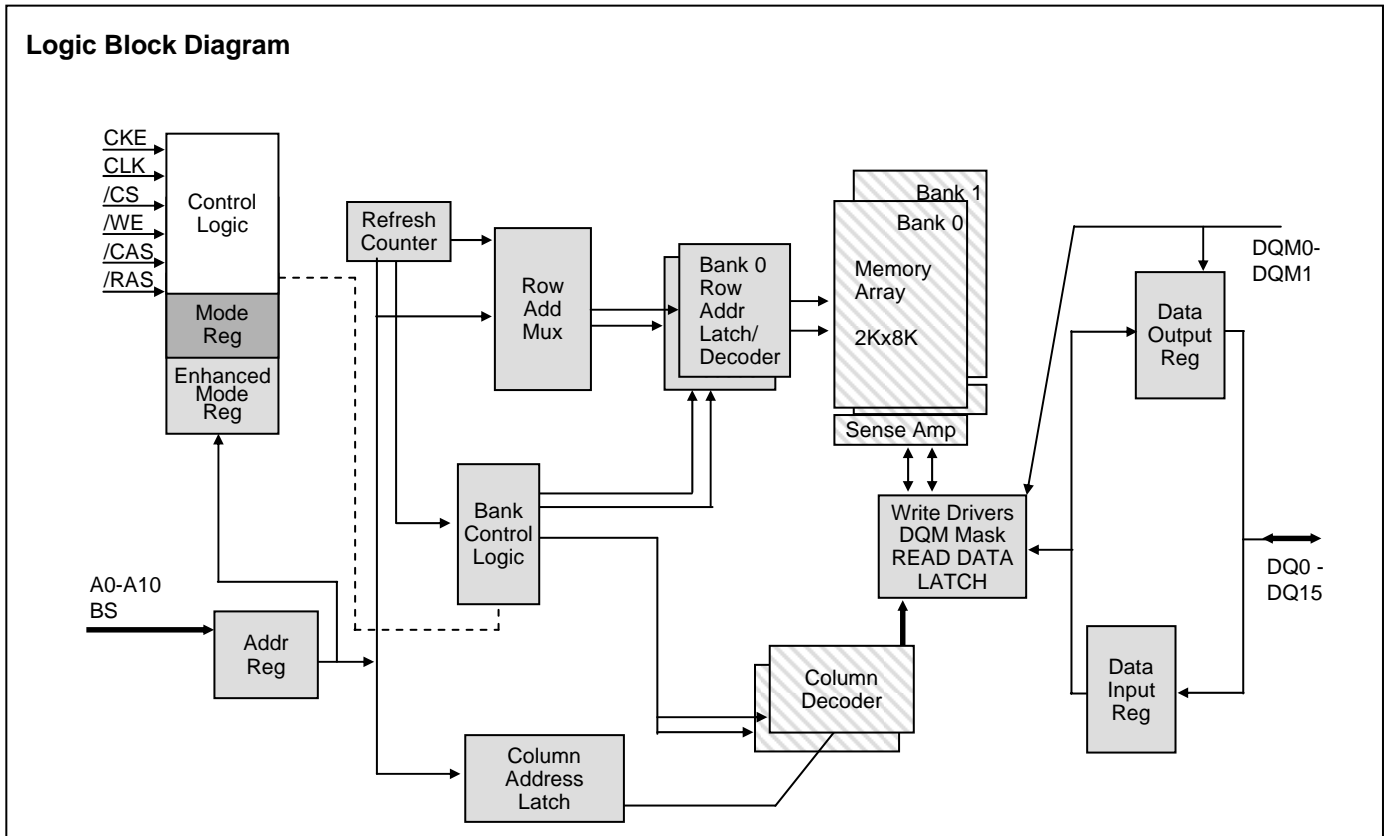
Logic Block Diagram

Selection Guide

Device	Voltage		Frequency	Access Time(t_{AC})		t_{RCD}	t_{RP}
	V_{DD}	V_{DDQ}		CL=2	CL=3		
CMS3216LAX-75xx	2.3-3.3V	1.65- V_{DD}	133MHz		6ns	18ns	18ns
			100MHz	7.5ns		20ns	20ns

Pin Configuration
54 ball FBGA(8mm x 8mm)

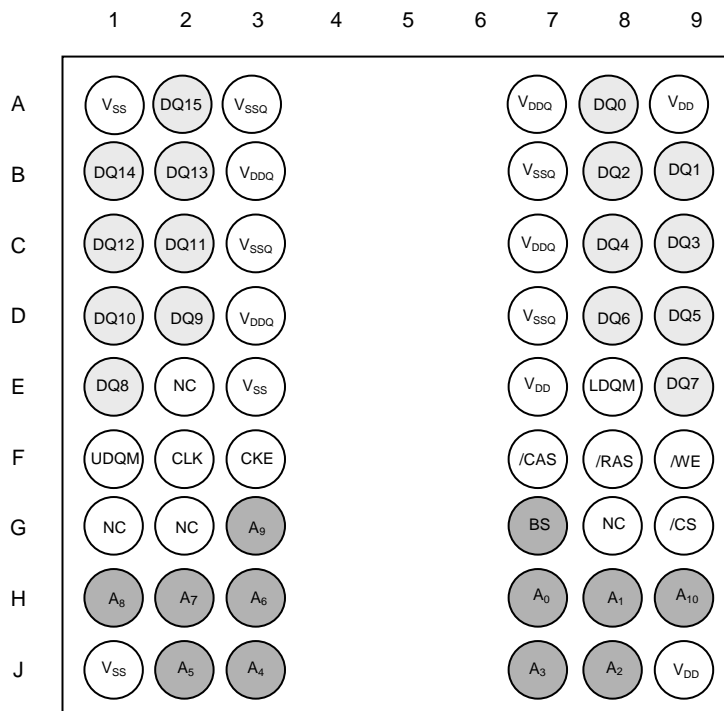
Top View



Pin Description

Symbol	Type	Description
CLK	Input	Clock : CLK is driven by the system clock. All SDRAM input signals are sampled on the positive edge of CLK. CLK also increments the internal burst counter and controls the output registers.
CKE	Input	Clock Enable: CKE activates(HIGH) and deactivates(LOW) the CLK signal. Deactivating the clock provides PRECHARGE POWER-DOWN and SELF REFRESH operation(all banks idle), ACTIVE POWER-DOWN(row active in any bank) or CLOCK SUSPEND operation(burst/access in progress). CKE is synchronous except after the device enters power-down and self refresh modes, where CKE becomes asynchronous until after exiting the same mode. The input buffers, including CLK, are disabled during power-down and self refresh modes, providing low standby power. CKE may be tied HIGH.
/CS	Input	Chip Select: CS# enables (registered LOW) and disables (registered HIGH) the command decoder. All commands are masked when /CS is registered HIGH. /CS provides for external bank selection on systems with multiple banks. /CS is considered part of the command code.
/CAS, /RAS, /WE	Input	Command Inputs : /CAS, /RAS, and /WE (along with /CS) define the command being entered.
DQM0 ~ DQM1	Input	Input/Output Mask: DQM is sampled HIGH and is an input mask signal for write accesses and an output enable signal for read accesses. Input data is masked during a WRITE cycle. The output buffers are placed in a High-Z state (two-clock latency) when during a READ cycle. DQM0 corresponds to DQ0 – DQ7, DQM1 corresponds to DQ8–DQ15,
BS	Input	Bank Address Input(s): BS define to which bank the ACTIVE, READ, WRITE or PRECHARGE command is being applied. These pins also provide the op-code during a LOAD MODE REGISTER command.
A0-A10	Input	Address Inputs: A0–A10 are sampled during the ACTIVE command (row-address A0–A10) and READ/WRITE command (column-address A0–A8; with A10 defining auto precharge) to select one location out of the memory array in the respective bank. A10 is sampled during a PRECHARGE command to determine if all banks are to be precharged (A10 HIGH) or bank selected by BS (A10 LOW). The address inputs also provide the op-code during a LOAD MODE REGISTER command.
DQ	I/O	Data Input/Output : Data bus
NC	-	No Connect
V _{DDQ}	Supply	DQ Power: Provide isolated power to DQs for improved noise immunity.
V _{SSQ}	Supply	DQ Ground: Provide isolated ground to DQs for improved noise immunity.
V _{DD}	Supply	Power Supply: Voltage dependent on option.
V _{SS}	Supply	Ground.

FUNCTIONAL DESCRIPTION

The Fidelix 32Mb SDRAM is a dual-bank DRAM that operates at 2.3~3.3V and includes a synchronous interface (all signals are registered on the positive edge of the clock signal, CLK). Each of 16,777,216-bit banks is organized as 2,048 rows by 512 columns by 16 bits. Read and write accesses to the SDRAM are burst oriented; accesses start at a selected location and continue for a programmed number of locations in a programmed sequence. Accesses begin with the registration of an ACTIVE command, which is then followed by a READ or WRITE command. The address bits registered coincident with the ACTIVE command are used to select the bank and row to be accessed (BS select the bank, A0- A10 select the row). The address bits (A0-A8) registered coincident with the READ or WRITE command are used to select the starting column location for the burst access. The SDRAM must be initialized prior to normal operation. The following sections provide detailed information regarding device initialization, register definition, command descriptions and device operation.

Initialization

SDRAMs must be powered up and initialized in a predefined manner. Operational procedures other than those specified may result in undefined operation. Once power is applied to V_{DD} and V_{DDQ} (simultaneously) and the clock is stable (meets the clock specifications in the AC characteristics), the SDRAM requires a 100 μ s delay prior to issuing any command other than a COMMAND INHIBIT or NOP. The COMMAND INHIBIT or NOP should be applied at least once during the 100 μ s delay. After the 100 μ s delay, a PRECHARGE command should be applied. All banks must then be precharged, thereby placing the device in the all banks idle state. Once in the idle state, two AUTO REFRESH cycles must be performed. After the AUTO REFRESH cycles are complete, the SDRAM is ready for mode register programming. Because the mode register will power up in an unknown state, it should be loaded prior to applying any operational command. Refer to Figure 1.

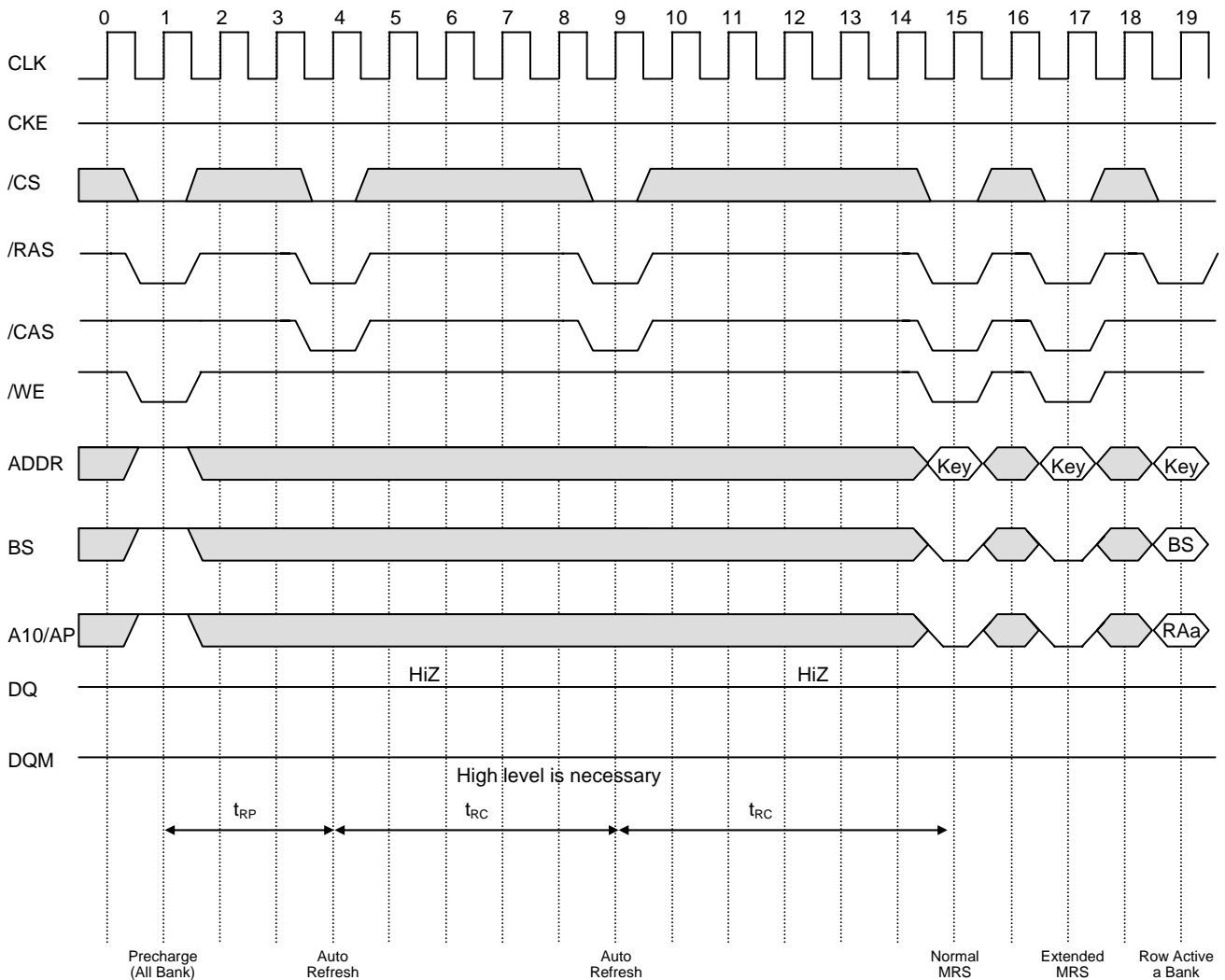
Figure 1. Initialize and Load Mode Register^[1,2,3]

Note :

1. The two AUTO REFRESH commands at T4 and T9 may be applied before either LOAD MODE REGISTER (LMR) command.
2. PRE = PRECHARGE command, LMR = LOAD MODE REGISTER command, AR = AUTO REFRESH command, ACT = ACTIVE command, RA = Row Address, BA = Bank Address
3. The Load Mode Register for both MR/EMR and 2 Auto Refresh commands can be in any order; However, all must occur prior to an Active command.

Register Definition

There are two mode registers which contain settings to achieve low power consumption. The two registers : Mode Register and Extended Mode Register are discussed below.

Mode Register

The mode register is used to define the specific mode of operation of the SDRAM. This definition includes the selection of a burst length, a burst type, a CAS latency, an operating mode and a write burst mode, as shown in Table 1. The mode register is programmed via the LOAD MODE REGISTER command and will retain the stored information until it is programmed again or the device loses power. Mode Register bits M0-M2 specify the burst length, M3 specifies the type of

burst (sequential or interleaved), M4-M6 specify the CAS latency, M7 and M8 specify the operating mode, M9 specifies the write burst mode, M10 and M11 should be set to zero. The Mode register must be loaded when all banks are idle, and the controller must wait the specified time before initiating the subsequent operation. Violating either of these requirements will result in unspecified operation.

Burst Length

Read and write accesses to the SDRAM are burst oriented. The burst length is programmable, as shown in Table 2. The burst length determines the maximum number of column locations that can be accessed for a given READ or WRITE command. Burst lengths of 1,2, 4, or 8 locations are available for both the

sequential and the interleaved burst types, and a full-page burst is available for the sequential type. The full-page burst is used in conjunction with the BURST TERMINATE command to generate arbitrary burst lengths. Reserved states should not be used, as unknown operation or incompatibility with future versions may result. When a READ or WRITE command is issued, a block of columns equal to the burst length is effectively selected. All accesses for that burst take place within this block, meaning that the burst will wrap within the block if a boundary is reached. The block is uniquely selected by A1-A8 when the burst length is set to two; by A2-A8 when the burst length is set to four; and by A3-A8 when the burst length is set to eight.

The remaining(least significant) address bit(s) is (are) used to select the starting location within the block. Full-page bursts wrap within the page if the boundary is reached.

Burst Type

The burst type can be set to either Sequential or Interleaved by using the M3 bit in the Mode register. The ordering of accesses within a burst is determined by the burst length, the burst type and the starting column address, as shown in Table 2. [4.5.6.7.8.9.10.]

M11-BS	M10-A10	M9-A9	M8-A8	M7-A7	M6-A6	M5-A5	M4-A4	M3-A3	M2-A2	M1-A1	M0-A0
Reserved(Set to '0')		WB	Op Mode		CAS Latency			BT	Burst Length		

M2 M1 M0	Burst Length	
	M3=0	M3=1
0 0 0	1	1
0 0 1	2	2
0 1 0	4	4
0 1 1	8	8
1 0 0	Reserved	Reserved
1 0 1	Reserved	Reserved
1 1 0	Reserved	Reserved
1 1 1	Full Page	Reserved

M3	Burst Type
0	Sequential
1	Interleaved

M9	Write Burst Mode
0	Prog. Burst Length
1	Single Mode Access

M6 M5 M4	CAS Latency
0 0 0	Reserved
0 0 1	1
0 1 0	2
0 1 1	3
1 0 0	Reserved
1 0 1	Reserved
1 1 0	Reserved
1 1 1	Reserved

M8	M7	M6-M0	Operating Mode
0	0	Defined	Standard Operation
-	-	-	All other states reserved

Note :

4. For full-page accesses: y = 256
5. For a burst length of two, A1-A8 select the block-of-two burst; A0 selects the starting column within the block.
6. For a burst length of four, A2-A8 select the block-of-four burst; A0-A1 select the starting column within the block.
7. For a burst length of eight, A3-A8 select the block-of-eight burst; A0-A2 select the starting column within the block.
8. For a full-page burst, the full row is selected and A0-A8 select the starting column.
9. Whenever a boundary of the block is reached within a given sequence above, the following access wraps within the block.
10. For a burst length of one, A0-A8 select the unique column to be accessed, and mode register bit M3 is ignored.

Table 1. Mode Register Definition.

Burst Length	Starting Column Address	Order of Accesses within a Burst	
		Type=Sequential	Type=Interleaved
2	A0		
	0	0-1	0-1
	1	1-0	1-0
4	A1 A0		
	0 0	0-1-2-3	0-1-2-3
	0 1	1-2-3-0	1-0-3-2
	1 0	2-3-0-1	2-3-0-1
	1 1	3-0-1-2	3-2-1-0
8	A2 A1 A0		
	0 0 0	0-1-2-3-4-5-6-7	0-1-2-3-4-5-6-7
	0 0 1	1-2-3-4-5-6-7-0	1-0-3-2-5-4-7-6
	0 1 0	2-3-4-5-6-7-0-1	2-3-0-1-6-7-4-5
	0 1 1	3-4-5-6-7-0-1-2	3-2-1-0-7-6-5-4
	1 0 0	4-5-6-7-0-1-2-3	4-5-6-7-0-1-2-3
	1 0 1	5-6-7-0-1-2-3-4	5-4-7-6-1-0-3-2
	1 1 0	6-7-0-1-2-3-4-5	6-7-4-5-2-3-0-1
	1 1 1	7-0-1-2-3-4-5-6	7-6-5-4-3-2-1-0
Full Page(y)	n=A0-A8(location 0-y)	Bn, Bn+1, Bn+2.....Bn,...	Not supported

Table 2. Burst Length Definition.

Operating Mode

The normal operating mode is selected by setting M7 and M8 to zero; the other combinations of values for M7 and M8 are reserved for future use and/or test modes. The programmed burst length applies to both READ and WRITE bursts. Test modes and reserved states should not be used because unknown operation or incompatibility with future versions may result.

CAS Latency

The CAS latency is the delay, in clock cycles, between the registration of a READ command and the availability of the first piece of output data. The latency can be set to one, two, or three clocks. If a READ command is registered at clock edge r , and the latency is q clocks, the data will be available by clock edge $r + q$. The DQs will start driving as a result of the clock edge one cycle earlier ($r + q - 1$), and provided that the relevant access times are met, the data will be valid by clock edge $r + q$. For example, assuming that the clock cycle time is such that all relevant access times are met, if a READ command is registered at T0 and the latency is programmed to two clocks, the DQs will start driving after T1 and the data will be valid by T2, as shown in Figure 2.

Reserved states should not be used as unknown operation or incompatibility with future versions may result.

Write Burst Mode

When M9=0, the burst length programmed via M0-M2 applies to both READ and WRITE bursts; when M9=1, the programmed burst length applies to READ bursts, but write accesses are single-location (non-burst) accesses.

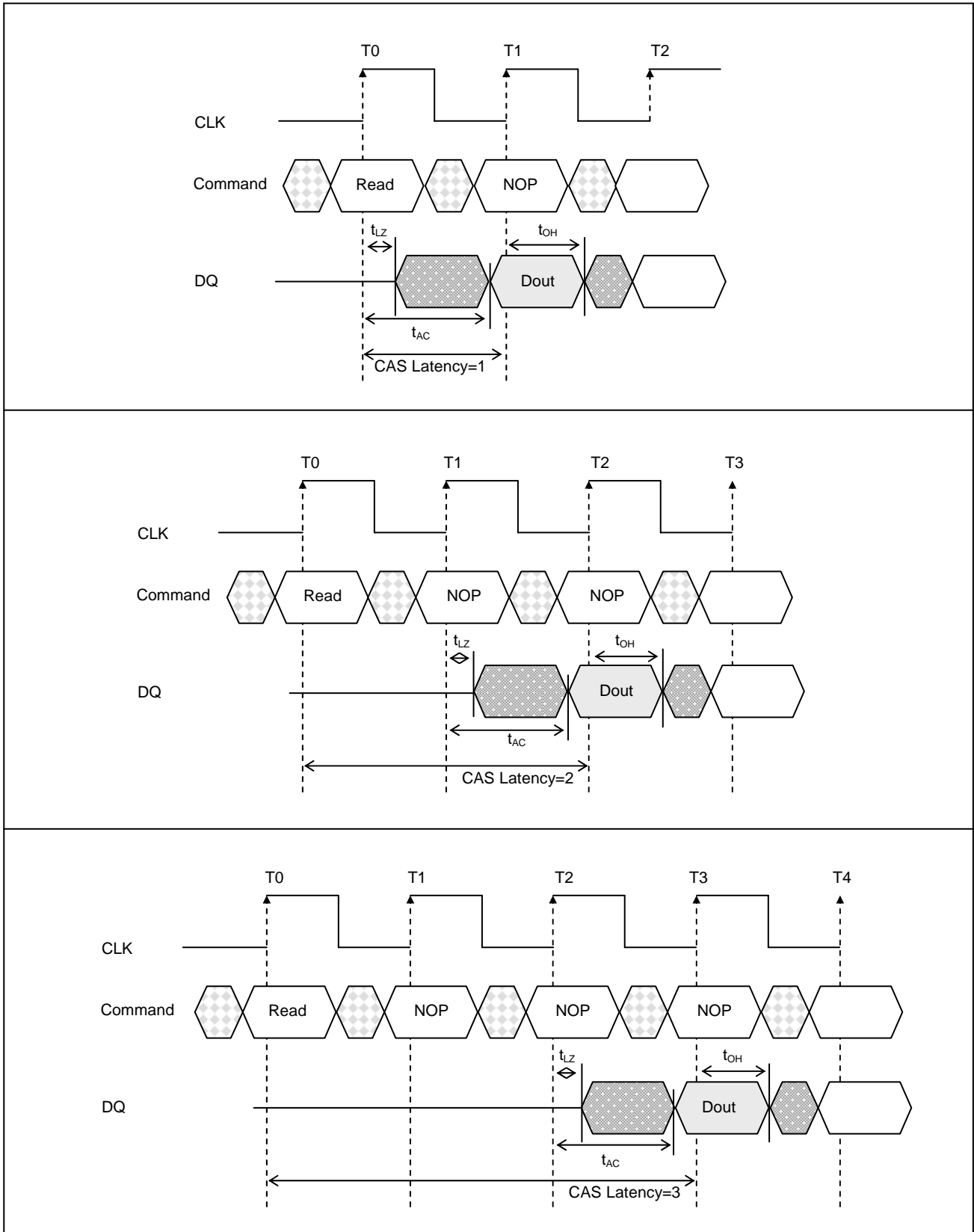

Figure 2. CAS Latency

EXTENDED MODE REGISTER

The Extended Mode Register controls additional functions such as Partial Array Self Refresh (PASR), and Output Drive Strength. The Extended Mode Register is programmed via the Mode Register Set command (BS=1) and retains the stored information until it is programmed again or the device loses power. The Extended Mode Register must be programmed with M8 through M10 set to "0". The Extended Mode Register must be loaded when all banks are idle and no bursts are in progress, and the controller must wait the specified time initiating any subsequent operation. Violating either of these requirements results in unspecified operation.

AUTO TEMPERATURE COMPENSATED SELF REFRESH

Every cell in the DRAM requires refreshing due to the capacitor losing its charge over time. The refresh rate is dependent on temperature. At higher temperatures a capacitor loses charge quicker than at lower temperatures, requiring the cells to be refreshed more often. In order to save power consumption, according to the temperature, Mobile-SDRAM includes the internal temperature sensor and control units to control the self refresh cycle automatically.

PARTIAL ARRAY SELF REFRESH

The Partial Array Self Refresh (PASR) feature allows the controller to select the amount of memory that will be refreshed during SELF REFRESH. The refresh options are all banks (banks 0, 1); one bank (bank 0 or 1 by M7). WRITE and READ commands occur to any bank selected during standard operation, but only the selected banks in PASR will be refreshed during SELF REFRESH. The data in banks 1 will be lost when the one bank option with M7=0 is used. Similarly the data will be lost in bank 0 when the one bank option with M7=1 is used down .

Driver Strength Control

The driver strength feature allows one to reduce the drive strength of the I/O's on the device during low frequency operation. This allows systems to reduce the noise associated with the I/O's switching.

Table 4. Extended Mode Register Definition

EM11-BS	EM10-A10	EM9-A9	EM8-A8	EM7-A7	EM6-A6	EM5-A5	EM4-A4	EM3-A3	EM2-A2	EM1-A1	EM0-A0
1	All must be set to '0'			Bank Up/Down	Driver Strength	0	0	PASR			

Table 5. Extended Mode Register Table^[11,12].

A7	A2	A1	A0	Self Refresh Coverage	A6	A5	Driver Strength
0	0	0	0	All Banks (Bank 0,1)	0	0	100%
	0	0	1	RFU	0	1	75%
	0	1	0	One Bank (Bank 0)	1	0	50%
	0	1	1	RFU	1	1	25%
	1	X	X	RFU			
1	0	0	0	All Banks (Bank 0,1)			
	0	0	1	RFU			
	0	1	0	One Bank (Bank1)			
	0	1	1	RFU			
	1	X	X	RFU			

Note :

11. EM11 (BS) must be "1" to select the Extended Mode Register(vs. the base Mode Register).
12. RFU: Reserved for Future Use

Table 6. Commands^[13,14,15,16,17,18,19,20] .

Name(Function)	CKE	/CS	/RAS	/CAS	/WE	DQM	ADDR	DQ
COMMAND INHIBIT(NOP)	X	H	X	X	X	X	X	X
NO OPERATION(NOP)	H	L	H	H	H	X	X	X
ACTIVE(Select bank and activate row) ^[15]	H	L	L	H	H	X	Bank/Row	X
READ(Select bank and column, and start READ burst) ^[16]	H	L	H	L	H	L/H	Bank/Col	X
WRITE(Select bank and column, and start WRITE burst) ^[16]	H	L	H	L	L	L/H	Bank/Col	Valid
BURST TERMINATE	H	L	H	H	L	X	X	Active
PRECHARGE(Deactivate row in bank or banks) ^[17]	H	L	L	H	L	X	Code	X
AUTO REFRESH or SELF REFRESH(Enter Self Refresh Mode) ^[18, 19]	H	L	L	L	H	X	X	X
LOAD MODE REGISTER) ^[14]	H	L	L	L	L	X	Opcode	X
Write Enable/Output Enable) ^[20]	H	-	-	-	-	L	-	Active
Write Inhibit/Output High-Z) ^[20]	H	-	-	-	-	H		High Z
Deep Power Down(Enter DPD Mode)	L	L	H	H	L	X	X	X

Table 6. Commands^[13,14,15,16,17,18,19,20,]
Note :

13. CKE is HIGH for all commands shown except SELF REFRESH.
14. A0-A10 define the op-code written to the mode register.
15. A0-A10 provide row address, and BS determine which bank is made active.
16. A0-A8 provide column address; A10 HIGH enables the auto precharge feature (non-persistent), while A10 LOW disables the auto precharge feature; BS determine which bank is being read from or written to.
17. A10 LOW: BS determine the bank being precharged. A10 HIGH: All banks precharged and BS is "Don't Care."
18. This command is AUTO REFRESH if CKE is HIGH, SELF REFRESH if CKE is LOW.
19. Internal refresh counter controls row addressing; all inputs and I/Os are "Don't Care" except for CKE.
20. Activates or deactivates the DQs during WRITES (zero-clock delay) and READs (two-clock delay).
DQM0 controls DQ 0-7, DQM1 controls DQ 8-15, DQM2 controls DQ 16-23 and DQM3 controls DQ 24-31.

Commands

Table 6. provides a reference of all the commands available with the state of the control signals for executing a specific command.

COMMAND INHIBIT

The COMMAND INHIBIT function effectively deselects the SDRAM by preventing new commands from being executed by the SDRAM, regardless of whether the CLK signal is enabled. Operations already in progress are not affected.

LOAD MODE REGISTER

The mode register is loaded via inputs A0-A10, BS. The LOAD MODE REGISTER and LOAD EXTENDED MODE REGISTER commands can only be issued when all banks are idle, and a subsequent executable command cannot be issued until t_{MRD} is met. Table 1. and Table 4. provide the definition for the Mode Register and Extended Mode Register.

NO OPERATION (NOP)

The NO OPERATION (NOP) command is used to perform a NOP to an SDRAM which is selected (/CS is LOW). This prevents unwanted commands from being registered during idle or wait states. Operations already in progress are not affected.

ACTIVE

The ACTIVE command is used to activate a row in a particular bank for a subsequent access. The value on the BS inputs selects the bank, and the address provided on inputs A0-A10 selects the row. This row remains active for accesses until a PRECHARGE command is issued to that bank. A PRECHARGE command must be issued before opening a different row in the same bank.

READ

READ command is used to initiate a burst read access to an active row. The value on the BS inputs selects the bank, and the address provided on inputs A0-A8 selects the starting column location. The value on input A10 determines whether or not auto precharge is used. If auto precharge is selected, the row being accessed will be precharged at the end of the READ burst. If auto precharge is not selected, the row will remain open for subsequent accesses. Read data appears on the DQs subject to the logic level on the DQM inputs two clocks earlier. If a given DQM signal was registered HIGH, the corresponding DQs will be High-Z two clocks later; if the DQM signal was registered LOW, the DQs will provide valid data.

WRITE

The WRITE command is used to initiate a burst write access to an active row. The value on the BS inputs selects the bank, and the address provided on inputs A0-A8 selects the starting column location. The value on input A10 determines whether or not auto precharge is used. If auto precharge is selected, the row being accessed will be precharged at the end of the WRITE burst. If auto precharge is not selected, the row will remain open for subsequent accesses. Input data appearing on the DQs is written to the memory array subject to the DQM input logic level appearing coincident with the data. If a given DQM signal is registered LOW, the corresponding data will be written to memory; if the DQM signal is registered HIGH, the corresponding data inputs will be ignored, and a WRITE will not be executed to that byte/column location.

PRECHARGE

The PRECHARGE command is used to deactivate the active row in a particular bank or the active row in all banks. The bank(s) will be available for a subsequent row access a specified time (t_{RP}) after the PRECHARGE command is issued. Input A10 determines whether one or all banks are to be precharged, and in the case where only one bank is to be precharged, inputs BS select the bank. Otherwise BS is treated as "Don't Care." Once a bank has been pre-charged, it is in the idle state and must be activated prior to any READ or WRITE commands being issued to that bank.

AUTO PRECHARGE

AUTO PRECHARGE is accomplished by using A10 to enable auto precharge in conjunction with a specific READ or WRITE command. AUTO PRECHARGE thus performs the same PRECHARGE command described above, without requiring an explicit command. A PRECHARGE of the bank/row that is addressed with the READ or WRITE command is automatically performed upon completion of the READ or WRITE burst. AUTO PRECHARGE does not apply in the full page mode burst. Auto precharge is nonpersistent in that it is either enabled or disabled for each individual READ or WRITE command. Auto precharge ensures that the precharge is initiated at the earliest valid stage within a burst. The user must not issue another command to the same bank until the precharge time (t_{RP}) is completed.

BURST TERMINATE

The BURST TERMINATE command is used to truncate either fixed-length or full-page bursts. The most recently registered READ or WRITE command prior to the BURST TERMINATE command will be truncated.

AUTO REFRESH

AUTO REFRESH is used during normal operation of the SDRAM. This command is nonpersistent, so it must be issued each time a refresh is required. All active banks must be PRECHARGED prior to issuing an AUTO REFRESH command. The AUTO REFRESH command should not be issued until the minimum t_{RP} has been met after the PRECHARGE command. The addressing is generated by the internal refresh controller. The address bits thus are a "Don't Care" during an AUTO REFRESH command. The Fidelix 32Mb SDRAM requires 2,048 AUTO REFRESH cycles every 64ms (t_{REF}), regardless of width option. Providing a distributed AUTO REFRESH command every 31.25 μ s will meet the refresh requirement and ensure that each row is refreshed.

Alternatively, 2,048 AUTO REFRESH commands can be issued in a burst at the minimum cycle rate (t_{RFC}), once every 64ms.

SELF REFRESH

The SELF REFRESH command can be used to retain data in the SDRAM (without external clocking), even if the rest of the system is powered down. The SELF REFRESH command is initiated like an AUTO REFRESH command except CKE is disabled (LOW). Once the SELF REFRESH command is registered, all the inputs to the SDRAM become "Don't Care" with the exception of CKE, which must remain LOW. Once self refresh mode is engaged, the SDRAM provides its own internal clocking, causing it to perform its own AUTO REFRESH cycles. The SDRAM must remain in self refresh mode for a minimum period equal to t_{RAS} and may remain in self refresh mode for an indefinite period beyond that. The procedure for exiting self refresh requires a sequence of commands. First, CLK must be stable (meet the clock specifications in the AC characteristics) prior to CKE going back HIGH. Once CKE is HIGH, the SDRAM must have NOP commands issued (a minimum of two clocks) for t_{XSR} because time is required for the completion of any internal refresh in progress. Upon exiting the self refresh mode, AUTO REFRESH commands must be issued every 31.25 μ s or less as both SELF REFRESH and AUTO REFRESH utilize the row refresh counter.

DEEP POWER DOWN

Deep Power Down Mode is an operating mode to achieve maximum power reduction by cutting the power of the whole memory array of the device.

Data will not be retained once the device enters DPD Mode.

Full initialization is required when the device exits from DPD Mode.

The DC value of DPD Mode can't be zero due to transistor's leakage current; a reverse PN diode leakage current which is called 'Junction leakage current' and a punch-through leakage current.

[Figure29.30]

Absolute Maximum Ratings

Voltage on V_{DD}/V_{DDQ} Supply
 Relative to V_{SS} -1V to + 3.3V
 Voltage on Inputs, NC or I/O Pins
 Relative to V_{SS} -1V to +3.3V
 Storage Temperature(plastic) -55°C to + 150°C
 Power Dissipation1W

*Stresses greater than those listed under “Maximum Ratings” may cause permanent damage to the device. This is a stress rating only, and functional operation of the device at these or any other conditions above those indicated in the operational sections of this specification is not implied. Exposure to absolute maximum rating conditions for extended periods may affect reliability.

Operating Range

Device	Range	Ambient Temperature	V_{DD}	V_{DDQ}
CMS3216LAX-75xS	Special	-10°C to +60°C	2.3V to 3.3V	1.65V to V_{DD}
CMS3216LAX-75xC	Commercial	0°C to +70°C		
CMS3216LAX-75xE	Extended	-25°C to +85°C		
CMS3216LAX-75xI	Industrial	-40°C to +85°C		

DC ELECTRICAL CHARACTERISTICS AND OPERATING CONDITIONS^[21,22]

Parameter / Condition	Symbol	Min	Max	Units
Supply Voltage	V_{DD}	2.3	3.3	V
I/O Supply Voltage	V_{DDQ}	1.65	3.3	V
Input High Voltage : Logic 1 All Inputs ^[23.]	V_{IH}	0.8* V_{DDQ}	$V_{DDQ} + 0.3$	V
Input Low Voltage : Logic 0 All Inputs ^[23.]	V_{IL}	-0.3	0.3	V
Data Output High Voltage : Logic 1 : All Inputs(-0.1mA)	V_{OH}	0.9* V_{DDQ}		V
Data Output Low Voltage : Logic 0 : All Inputs(0.1mA)	V_{OL}		0.2	V
Input Leakage Current : Any Input 0V= $V_{IN}=V_{DD}$ (All other pins not under test=0V)	I _I	-5	5	μA
Output Leakage Current : DQs are disabled ; 0V= $V_{OUT}=V_{DDQ}$	I _{OZ}	-5	5	μA

Table 7. AC OPERATING CONDITIONS^[21.22.23.24.25.26.]

Parameter / Condition	Symbol	Value	Units
Input High Voltage : Logic 1 All Inputs	V_{IH}	0.9* V_{DDQ}	V
Input Low Voltage : Logic 0 All Inputs	V_{IL}	0.2	V
Input and Output Measurement Reference Level		0.5* V_{DDQ}	V

Table 8. I_{DD} Specifications and Conditions [21.22.26.27.]

Parameter	Description	-75	Units
I _{DD1}	Operating Current : Active Mode ; Burst =1 ; Read or Write ; t _{RC} = t _{RC} (min); CAS Latency =3 [28.29.30.]	45	mA
I _{DD2p}	Precharge Standby Current in Power Down Mode ; CKE=LOW ; All banks Idle	300	μA
I _{DD2n}	Precharge Standby Current in non ower down Mode; CKE=HIGH ; All banks Idle	12	mA
I _{DD3p}	Active Standby Current in Power Down Mode ; CS#=HIGH ; CKE=LOW ; All banks active after t _{RC} D met ; No access in progress[28.30.31.]	2	mA
I _{DD3n}	Active Standby Current in non Power Down Mode ; CS#=HIGH ; CKE=HIGH ; All banks active after t _{RC} D met ; No access in progress[28.30.31.]	16	mA
I _{DD4}	Operating Current : Burst Mode ; Continuous Burst ; Read or Write ; All banks Active ; CAS Latency =3[28.29.30.]	45	mA
I _{DD5}	Auto Refresh Current : t _{RC} =t _{RC} (min) CAS Latency=3 ; CKE,CS#=HIGH[28.29.30.32.32.]	70	mA
I _{DD6}	Self Refresh Current : CKE <=0.2V, 2 Banks	200	μA
	Self Refresh Current : CKE <=0.2V, 1 Banks	150	μA
I _{DD7}	Deep power down	10	μA

Note :

21. The minimum specifications are used only to indicate cycle time at which proper operation over the full temperature range (-40°C = TA = +85°C for IT parts) is ensured.
22. An initial pause of 100μs is required after power-up, followed by two AUTO REFRESH commands, before proper device operation is ensured. (V_{DD} and V_{DDQ} must be powered up simultaneously. V_{SS} and V_{SSQ} must be at same potential.) The two AUTO REFRESH command wake-ups should be repeated any time the t_{REF} refresh requirement is exceeded.
23. All states and sequences not shown are illegal or reserved.
24. In addition to meeting the transition rate specification, the clock and CKE must transit between V_{IH} and V_{IL} (or between V_{IL} and V_{IH}) in a monotonic manner.
25. t_{HZ} defines the time at which the output achieves the open circuit condition; it is not a reference to V_{OH} or V_{OL}. The last valid data element will meet t_{OH} before going High-Z.
26. AC timing and I_{DD} tests have V_{IL} and V_{IH}, with timing referenced to V_{IH2} = crossover point. If the input transition time is longer than t_r (MAX), then the timing is referenced at V_{IL} (MAX) and V_{IH} (MIN) and no longer at the V_{IH2} crossover point.
27. I_{DD} specifications are tested after the device is properly initialized.
28. I_{DD} is dependent on output loading and cycle rates. Specified values are obtained with minimum cycle time and the outputs open.
29. The I_{DD} current will increase or decrease proportionally according to the amount of frequency alteration for the test condition.
30. Address transitions average one transition every two clocks.
31. Other input signals are allowed to transition no more than once every two clocks and are otherwise at valid V_{IH} or V_{IL} levels.
32. CKE is HIGH during refresh command period t_{RFC} (MIN) else CKE is LOW. The I_{DD} 6 limit is actually a nominal value and does not result in a fail value

Capacitance

Parameter	Description	Test Conditions	Max	Units
C _{IN}	Input Capacitance	T _A =25°C, f=1Mhz, V _{DD} (typ)	4	pF
C _{OUT}	Output Capacitance		6	pF

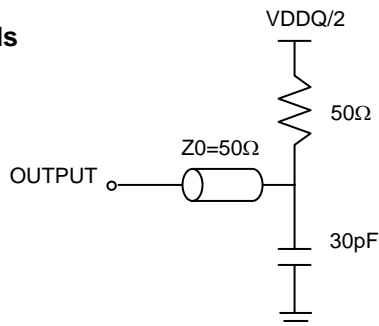
AC Test Loads

AC Characteristics

AC Characteristics		Symbol	-75		Units
			Min	Max	
Parameter					
Clock Period ^[33.]		tCLKS3	7.5		ns
		tCLKS2	10		ns
Clock High Time		tCH	2.5		ns
Clock Low Time		tCL	2.5		ns
Address Setup Time to Clock		tCAS	2.0		ns
Address Hold Time to Clock		tCAH	1.0		ns
CKE Setup Time to Clock		tCKS	2.0		ns
CKE Hold Time to Clock		tCKH	1.0		ns
Clock Access Time	CL=3	tAC(3)		6	ns
	CL=2	tAC(2)		7.5	ns
	CL=1	tAC(1)		-	ns
Output Hold Time from Clock		tOH	2.5		ns
Data In Setup Time to Clock		tCDS	2.0		ns
Data In Hold Time to Clock		tCDH	1.0		ns
/CS, /RAS, /CAS, /WE, /DQM Setup Time to Clock		tCMS	2.0		ns
/CS, /RAS, /CAS, /WE, /DQM Hold Time to Clock		tCMH	1.0		ns
Data High Impedance Time ^[25.]	CL=3	tHZ(3)		6	ns
	CL=2	tHZ(2)		7.5	ns
	CL=1	tHZ(1)		-	ns
Active to Precharge Command		tRAS	45	120000	ns
Active to Active Command Period		tRC	70		ns
Active to Read/Write Delay		tRCD	18		ns
Refresh Period(2048 rows)		tREF		64	ms
Auto Refresh Period		tRFC	70		ns
Precharge Command Period		tRP	18		ns
Active Banka to Active Bankb Command		tRRD	15		ns
Transition Time ^[34.]		tT	0.5	1.2	ns
Write Recovery Time ^[35.]		tWR	2		tck
Write Recovery Time ^[36.]		tWR	15		ns
Exit Self Refresh to Active Command ^[37.]		tXSR	80		ns
READ/WRITE command to READ/WRITE command ^[38.]		tCCD	1		tck
CKE to clock disable or power-down entry mode ^[39.]		tCKED	1		tck
CKE to clock enable or power-down exit setup mode ^[39.]		tPED	1		tck
DQM to input data delay ^[38.]		tDQD	0		tck
DQM to data mask during WRITES ^[38.]		tDQM	0		tck
DQM to data high-impedance during READS ^[38.]		tDQZ	2		tck
WRITE command to input data delay ^[38.]		tDWD	0		tck
Data-in to ACTIVE command ^[40.]		tDAL	tWR+tRP		ns
Data-in to PRECHARGE command ^[41.]		tDPL	2		tck
Last data-in to burst STOP command ^[38.]		tBDL	1		tck

AC Characteristics

AC Characteristics		Symbol	-75		Units
Parameter			Min	Max	
Last data-in to new READ/WRITE command ^[38.]		tCDL	1		tCK
Last data-in to PRECHARGE command ^[41.]		tRDL	2		tCK
LOAD MODE REGISTER command to ACTIVE or REFRESH command ^[42.]		tMRD	2		tCK
Data-out to high-impedance from PRECHARGE command ^[38.]	CL=3	tROH(3)	3		tCK
	CL=2	tROH(2)	2		tCK
	CL=1	tROH(1)	1		tCK

Note :

33. The clock frequency must remain constant (stable clock is defined as a signal cycling within timing constraints specified for the clock pin) during access or precharge states (READ, WRITE, including t_{WR} , and PRECHARGE commands). CKE may be used to reduce the data rate.
34. AC characteristics assume $t_T = 1\text{ ns}$.
35. Auto precharge mode only.
36. Precharge mode only.
37. CLK must be toggled a minimum of two times during this period.
38. Required clocks are specified by JEDEC functionality and are not dependent on any timing parameter.
39. Timing actually specified by t_{CKS} ; clock(s) specified as a reference only at minimum cycle rate.
40. Timing actually specified by t_{WR} plus t_{RP} ; clock(s) specified as a reference only at minimum cycle rate.
41. Timing actually specified by t_{WR} .
42. JEDEC and PC100 specify three clocks.

Operation

BANK / ROW ACTIVATION

Before any READ or WRITE commands can be issued to a bank within the SDRAM, a row in that bank must be “opened” (activated). This is accomplished via the ACTIVE command, which selects both the bank and the row to be activated. A READ or WRITE command may then be issued to that row, subject to the t_{RCD} specification. t_{RCD} (MIN) should be divided by the clock period and rounded up to the next whole number to determine the earliest clock edge after the ACTIVE command on which a READ or WRITE command can be entered. For example, a t_{RCD} specification of 20ns with a 125 Mhz clock (8ns period) results in 2.5 clocks, rounded to 3. (The same procedure is used to convert other specification limits from time units to clock cycles.) A subsequent ACTIVE command to a different row in the same bank can only be issued after the previous active row has been “closed” (precharged). The minimum time interval between successive ACTIVE commands to the same bank is defined by t_{RC} . A subsequent ACTIVE command to another bank can be issued while the first bank is being accessed, which results in a reduction of total row-access overhead. The minimum time interval between successive ACTIVE commands to different banks is defined by t_{RRD} .

READS

READ bursts are initiated with a READ command, as shown in

Figure 3. The starting column and bank addresses are provided with the READ command, and auto precharge is either enabled or disabled for that burst access. For the generic READ commands used in the following illustrations, auto precharge is disabled. During READ bursts, the valid data-out element from the starting column address will be available following the CAS latency after the READ command. Each subsequent data-out element will be valid by the next positive clock edge. Figure 2. shows general timing for each possible CAS latency setting.

Upon completion of a burst, assuming no other commands have been initiated, the DQs will go High-Z. A fullpage burst will continue until terminated. (The burst will wrap around at the end of the page). A continuous flow of data can be maintained by having additional Read Burst or single Read Command. The first data element from the new burst follows either the last element of a completed burst or the last desired data element of a longer burst that is being truncated.

The new READ command should be issued x cycles before the clock edge at which the last desired data element is valid, where x equals the CAS latency minus one.

This is shown in Figure 4. for CAS latencies of one, two and three; data element $n + 3$ is either the last of a burst of four or the last desired of a longer burst. Full-speed random read accesses can be performed to the same bank, as shown in Figure 5. , or each subsequent READ may be performed to a different bank.

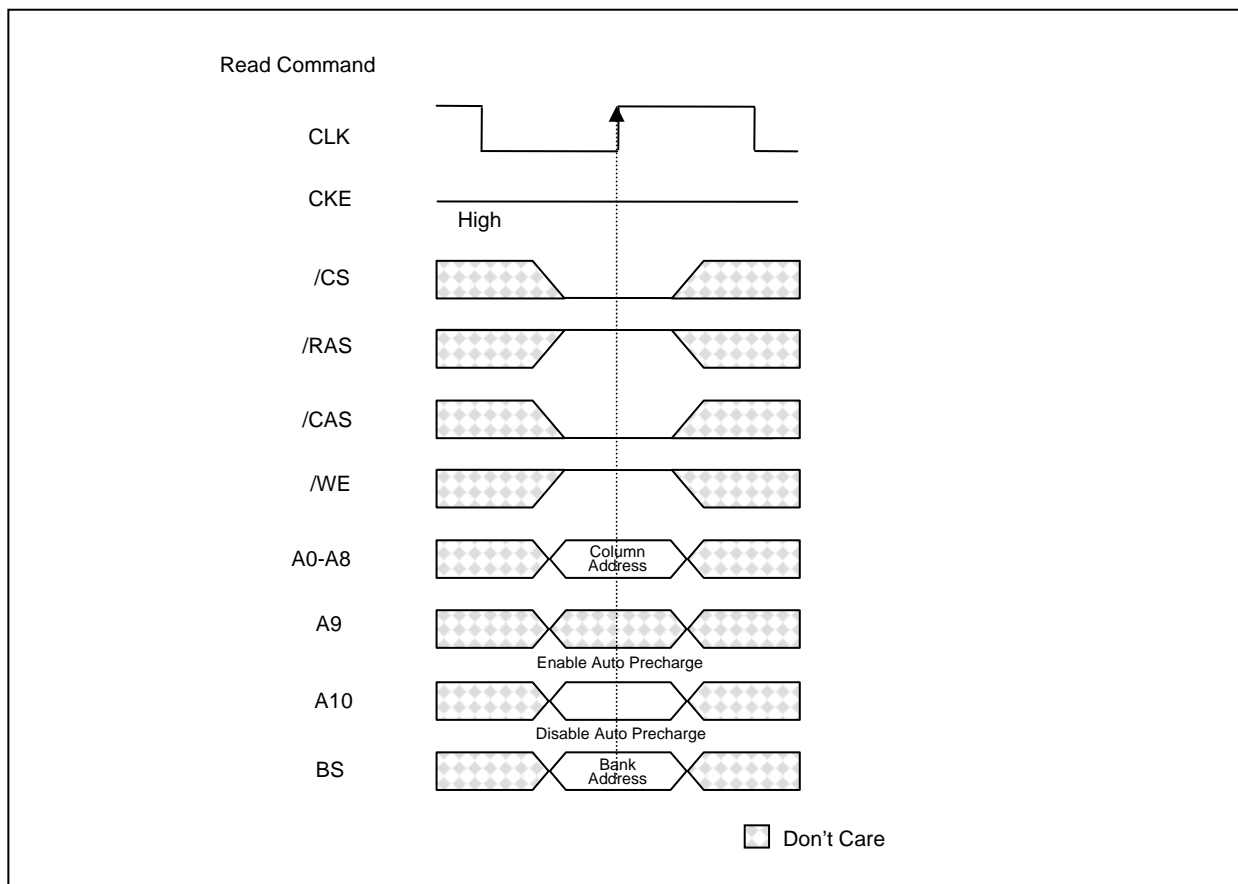

Figure 3. Read Command

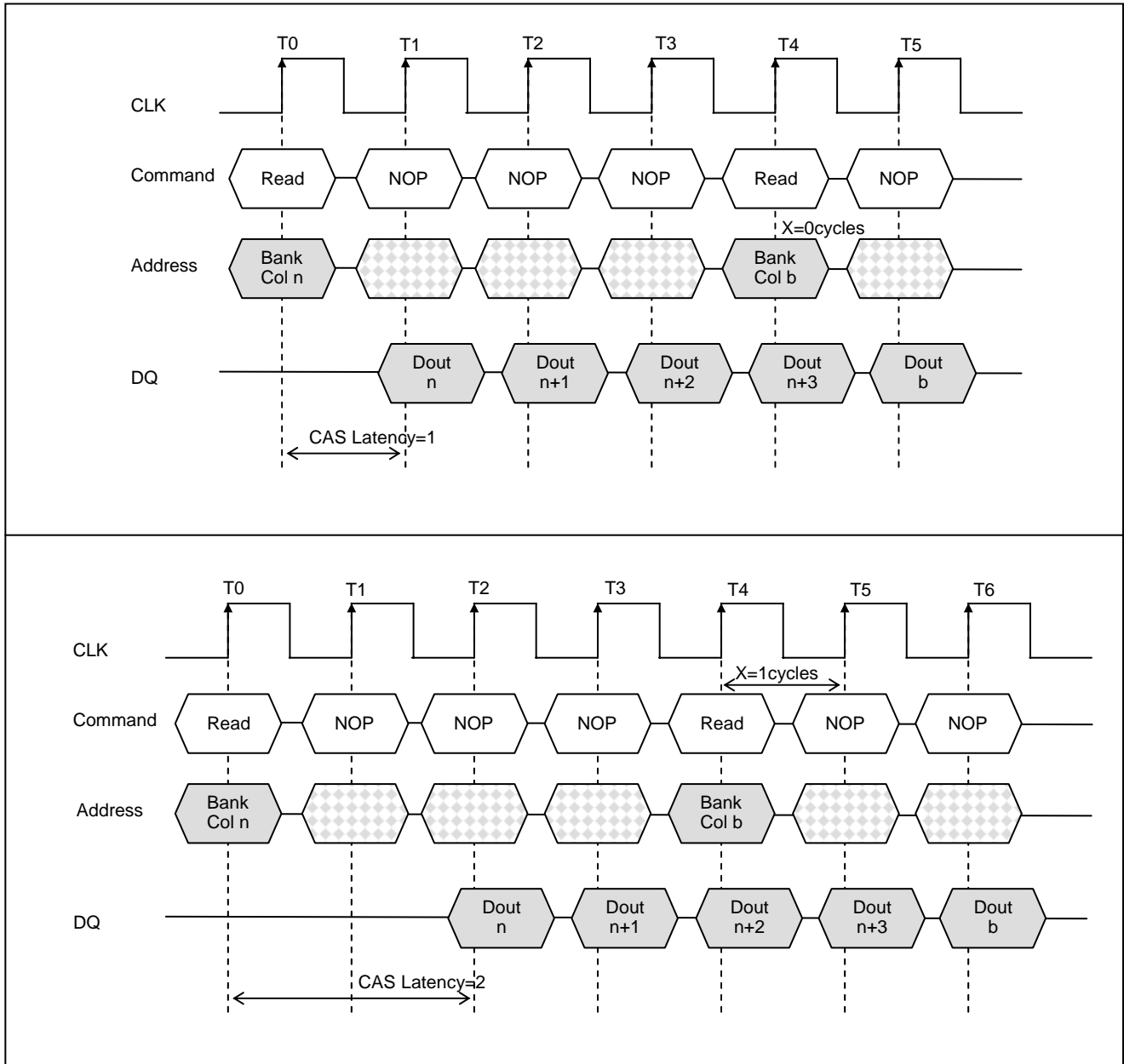

Figure 4. Consecutive Burst Reads -Transition from Burst of 4 Read to a Single read for CAS Latency 1,2,3

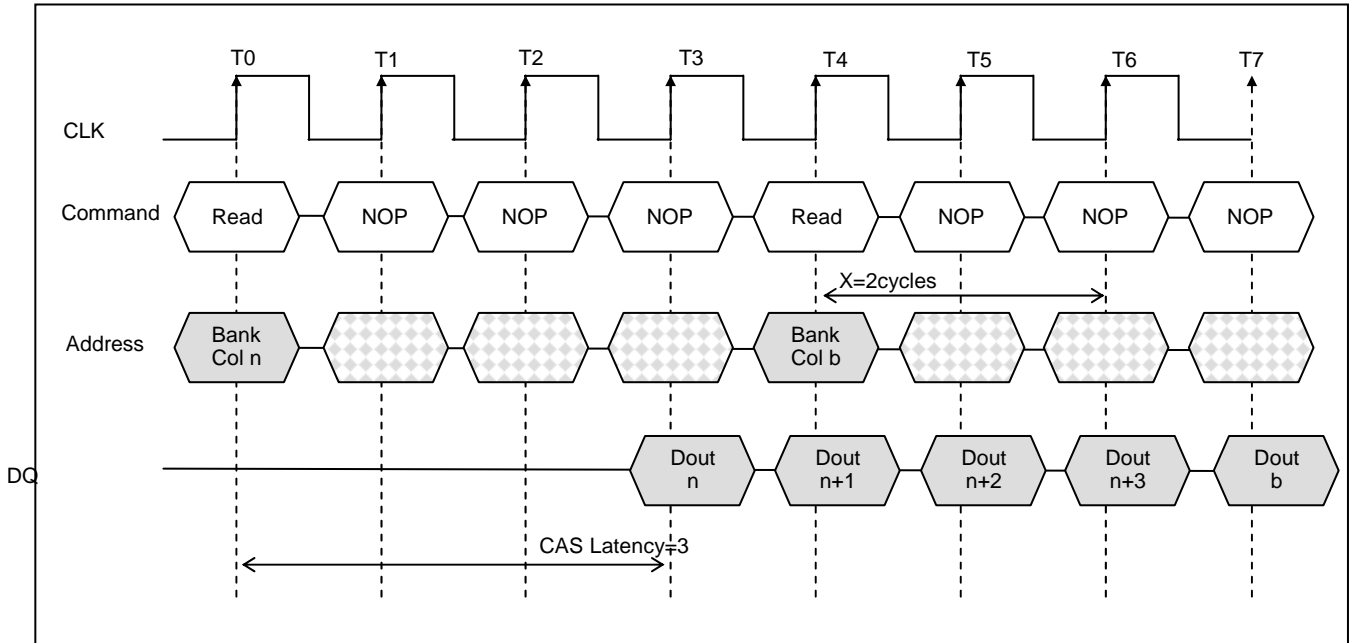

Figure 4. Consecutive Burst Reads -Transition from Burst of 4 Read to a Single read for CAS Latency 1,2,3

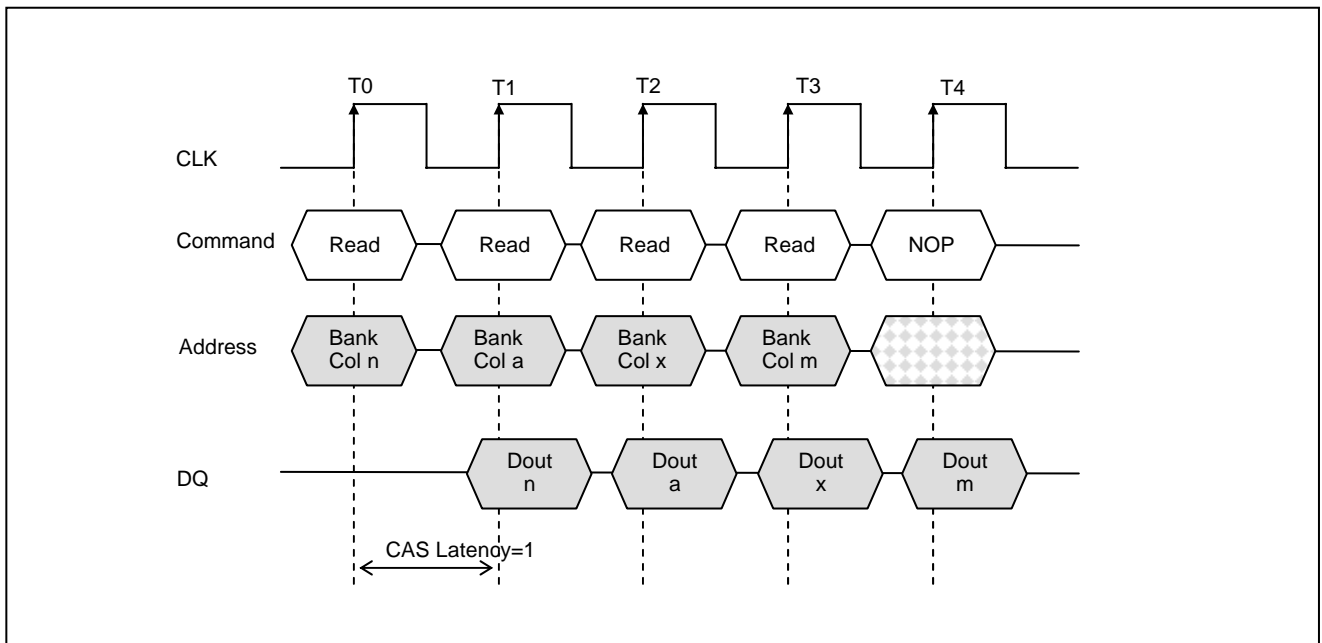

Figure 5. Random Read Accesses for CAS Latency =1,2,3

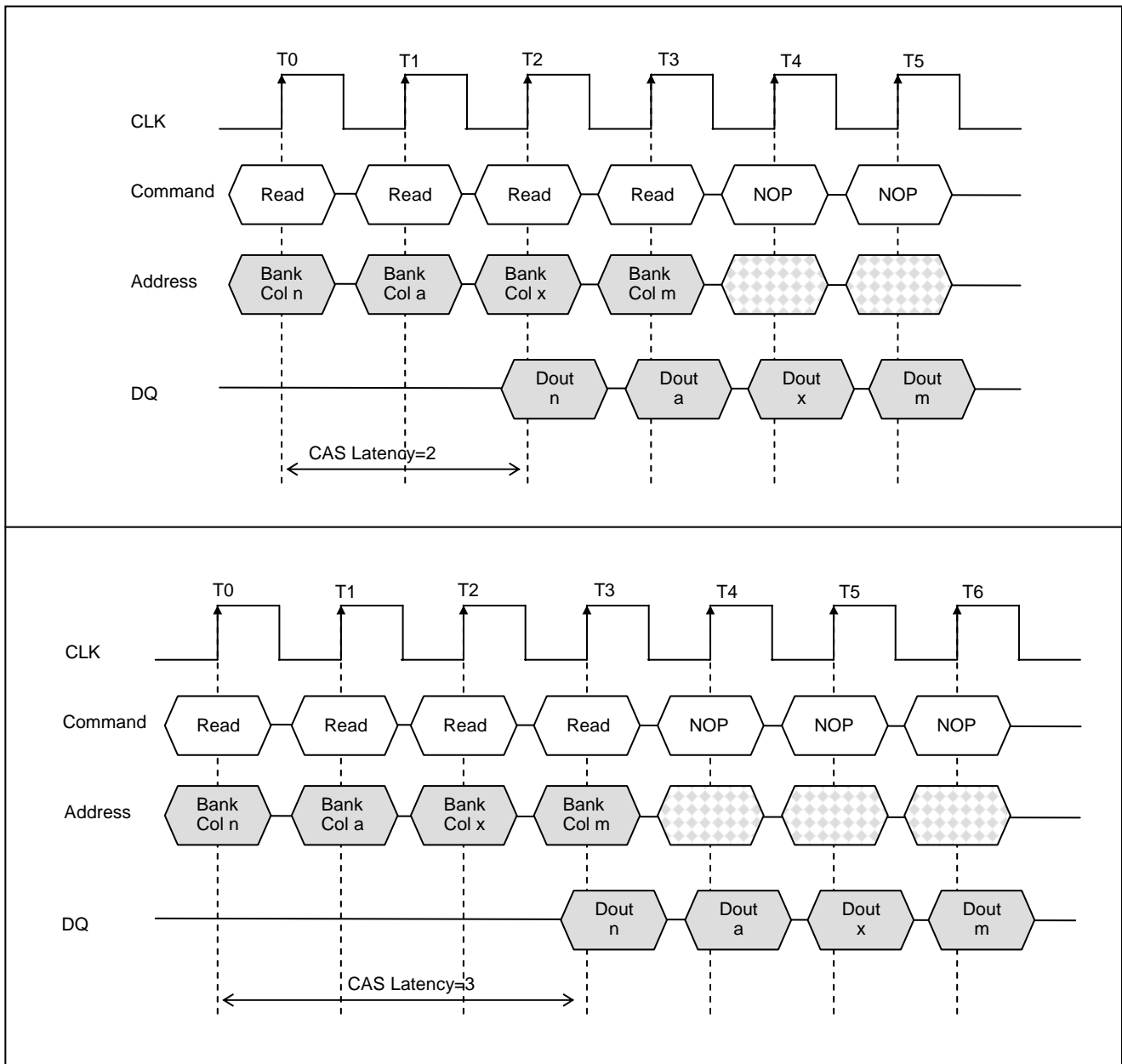

Figure 5. Random Read Accesses for CAS Latency =1,2,3

A Read Burst can be terminated by a subsequent Write command, and data from a fixed length READ burst may be immediately followed by data from a WRITE command (subject to bus turnaround limitations). The WRITE burst may be initiated on the clock edge immediately following the last (or last desired) data element from the READ burst, provided that I/O contention can be avoided. In a given system design, there may be a possibility that the device driving the input data will go Low-Z before the SDRAM DQs go High-Z. In this case, at least

a single-cycle delay should occur between the last read data and the WRITE command. The DQM input is used to avoid I/O contention, as shown in Figure 6. and Figure 7. . The DQM signal must be asserted (HIGH) at least two clocks prior to the WRITE command (DQM latency is two clocks for output buffers) to suppress data-out from the READ. Once the WRITE command is registered, the DQs will go High-Z (or remain High-Z), regardless of the state of the DQM signal, provided the DQM

was active on the clock just prior to the WRITE command that truncated the READ command. The DQM signal must be asserted prior to the WRITE command (DQM latency is zero clocks for input buffers) to ensure that the written data is not masked. Figure 6. shows the case where the clock frequency

allows for bus contention to be avoided without adding a NOP cycle, and Figure 7. shows the case where the additional NOP is needed.

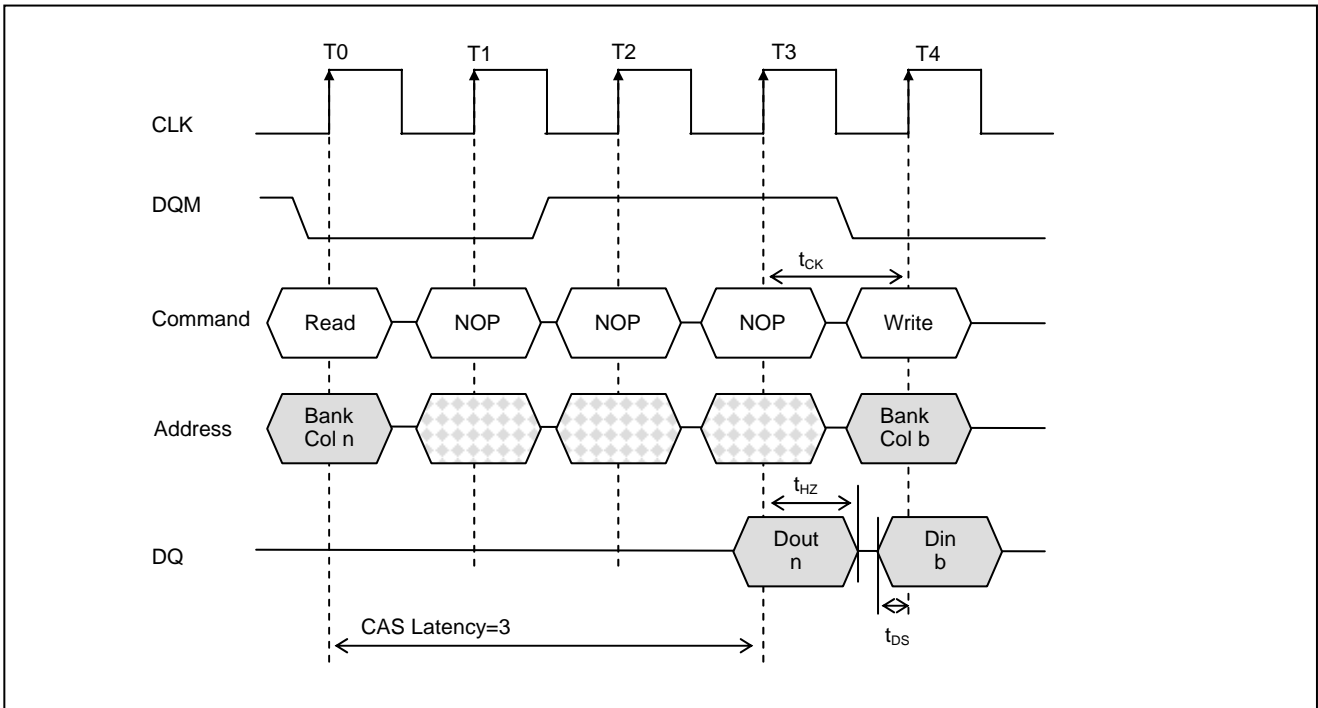

Figure 6. Read to Write

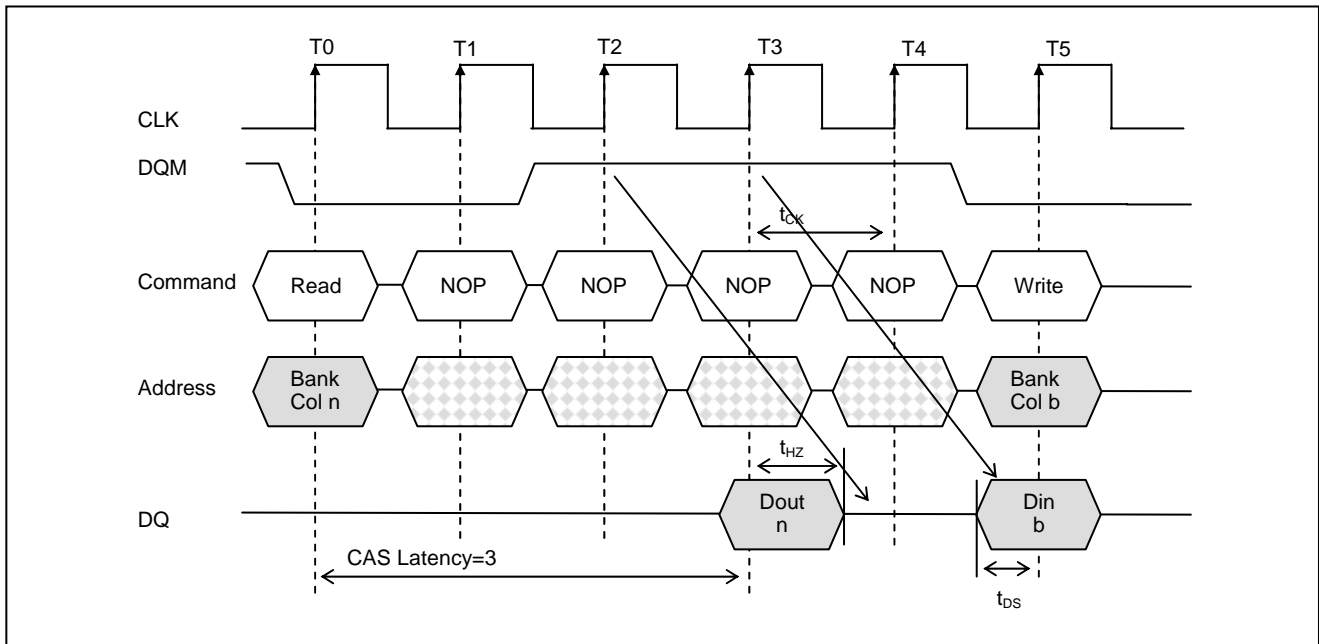

Figure 7. Read to Write with extra clock cycle

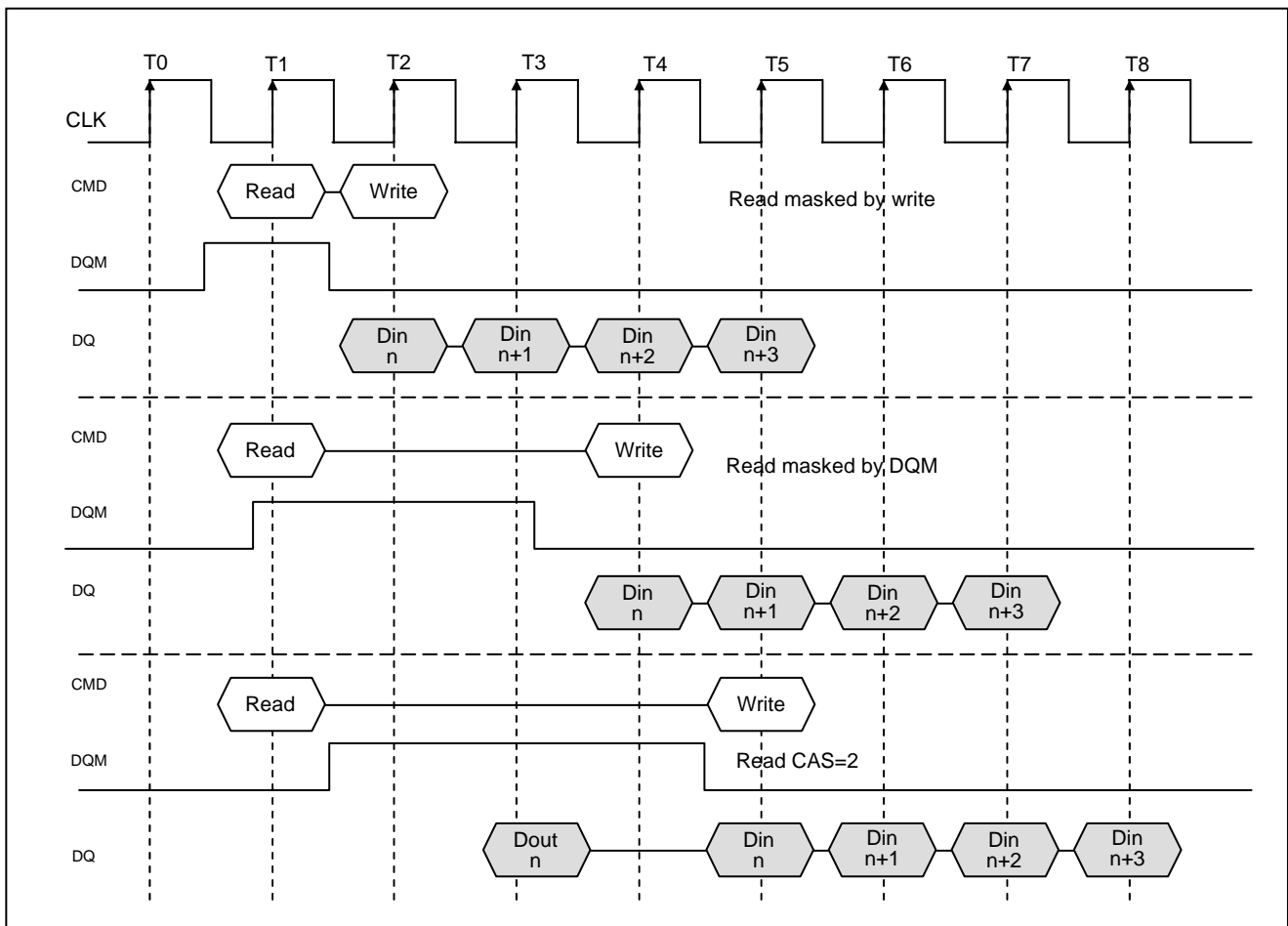

Figure 8. Read Interrupted by Write and DQM ; CAS Latency =2

A fixed-length READ burst or a full-page burst may be followed by, or truncated with, a PRECHARGE command to the same bank. The PRECHARGE command should be issued x cycles before the clock edge at which the last desired data element is valid, where x equals the CAS latency minus one. This is shown in Figure 9. for each possible CAS latency; data element $n + 3$ is either the last of a burst of four or the last desired of a longer burst. Following the PRECHARGE command,

a subsequent command to the same bank cannot be issued until t_{RP} is met. Note that part of the row precharge time is hidden during the access of the last data element(s). The BURST TERMINATE command should be issued x cycles before the clock edge at which the last desired data element is valid, where x equals the CAS latency minus one. This is shown in Figure 10. for each possible CAS latency; data element $n + 3$ is the last desired data element of a longer burst.

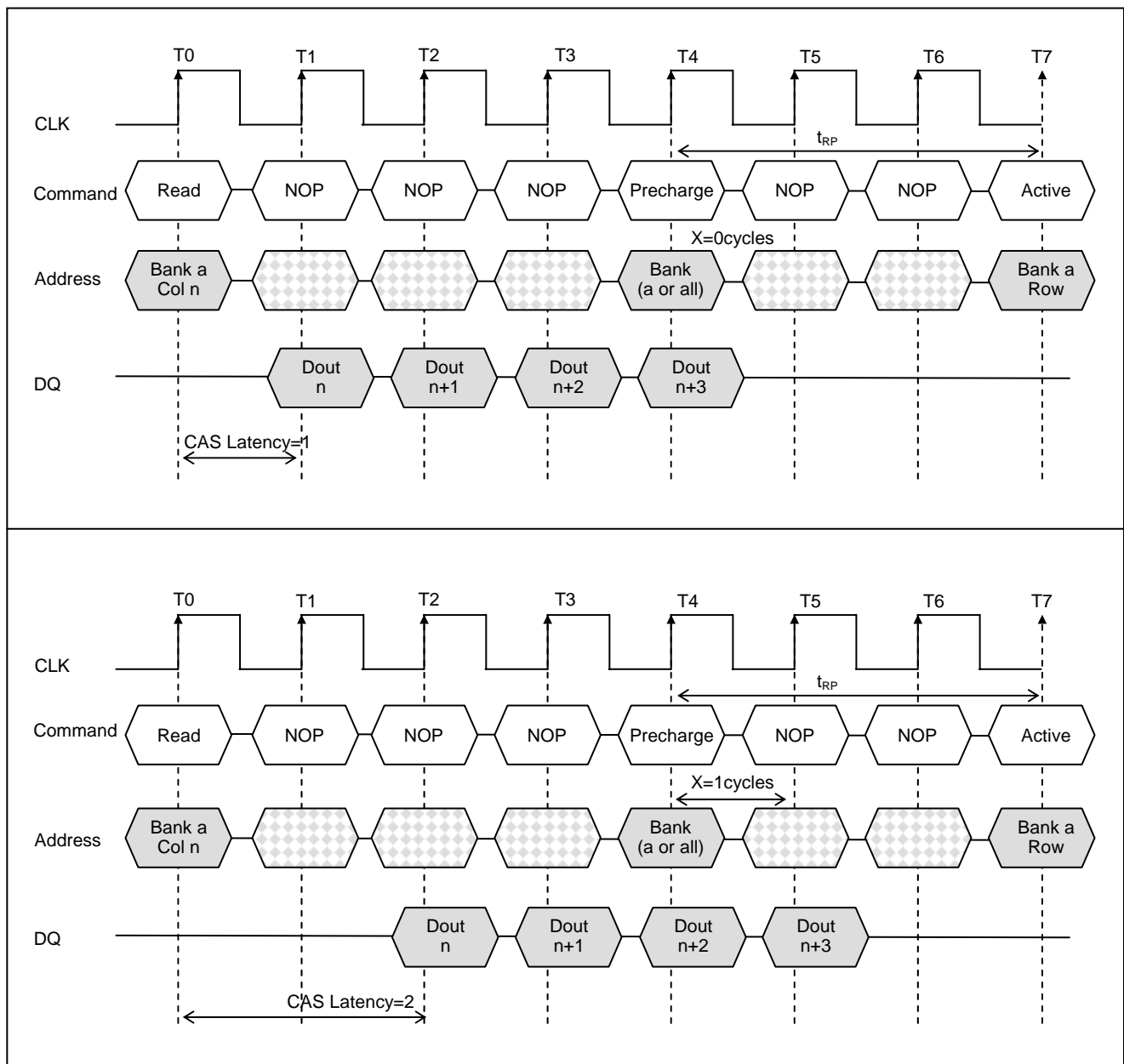

Figure 9. Read to Precharge

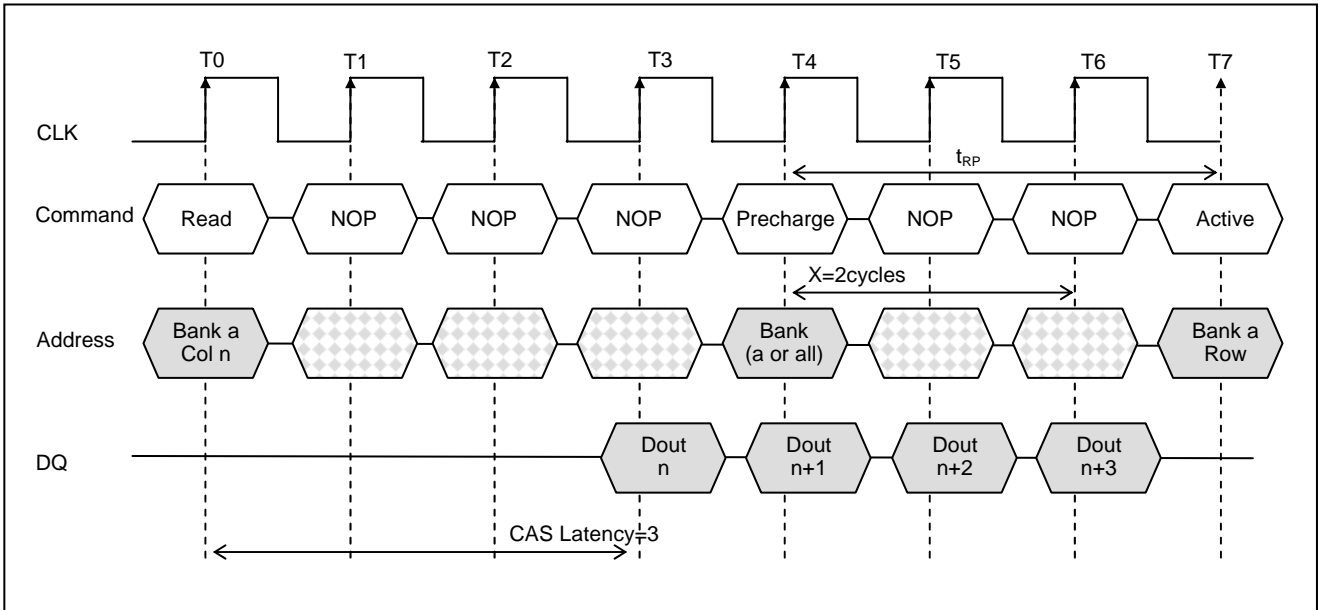

Figure 9. Read to Precharge

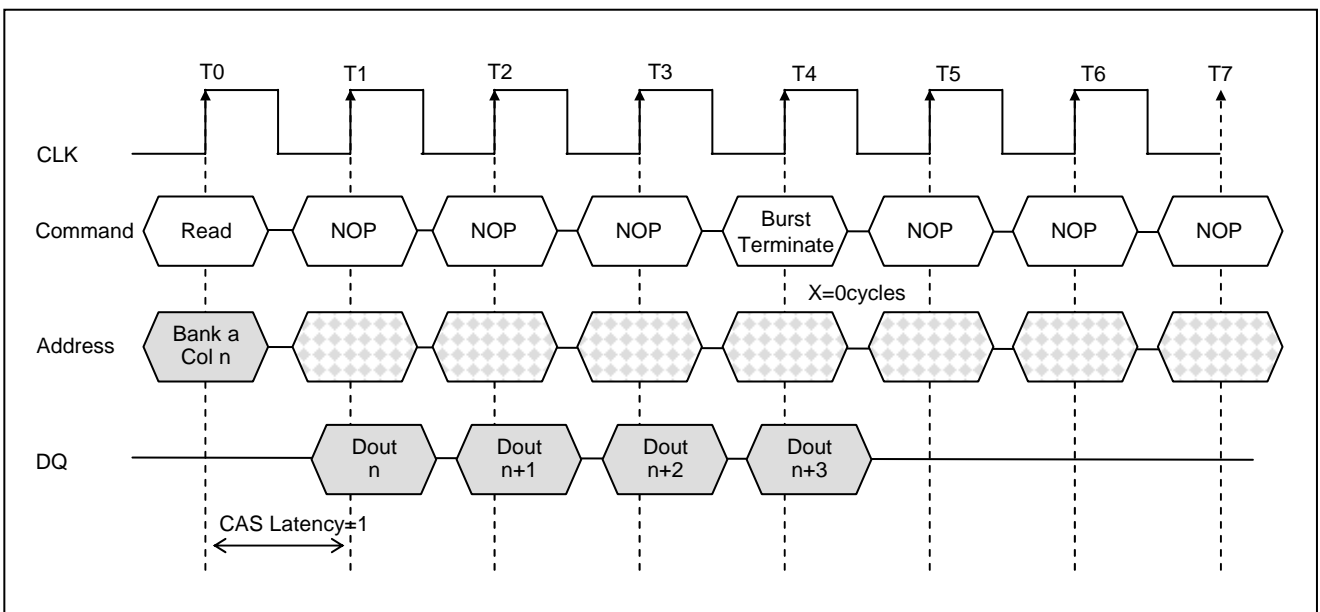

Figure 10. Terminating a Read Burst

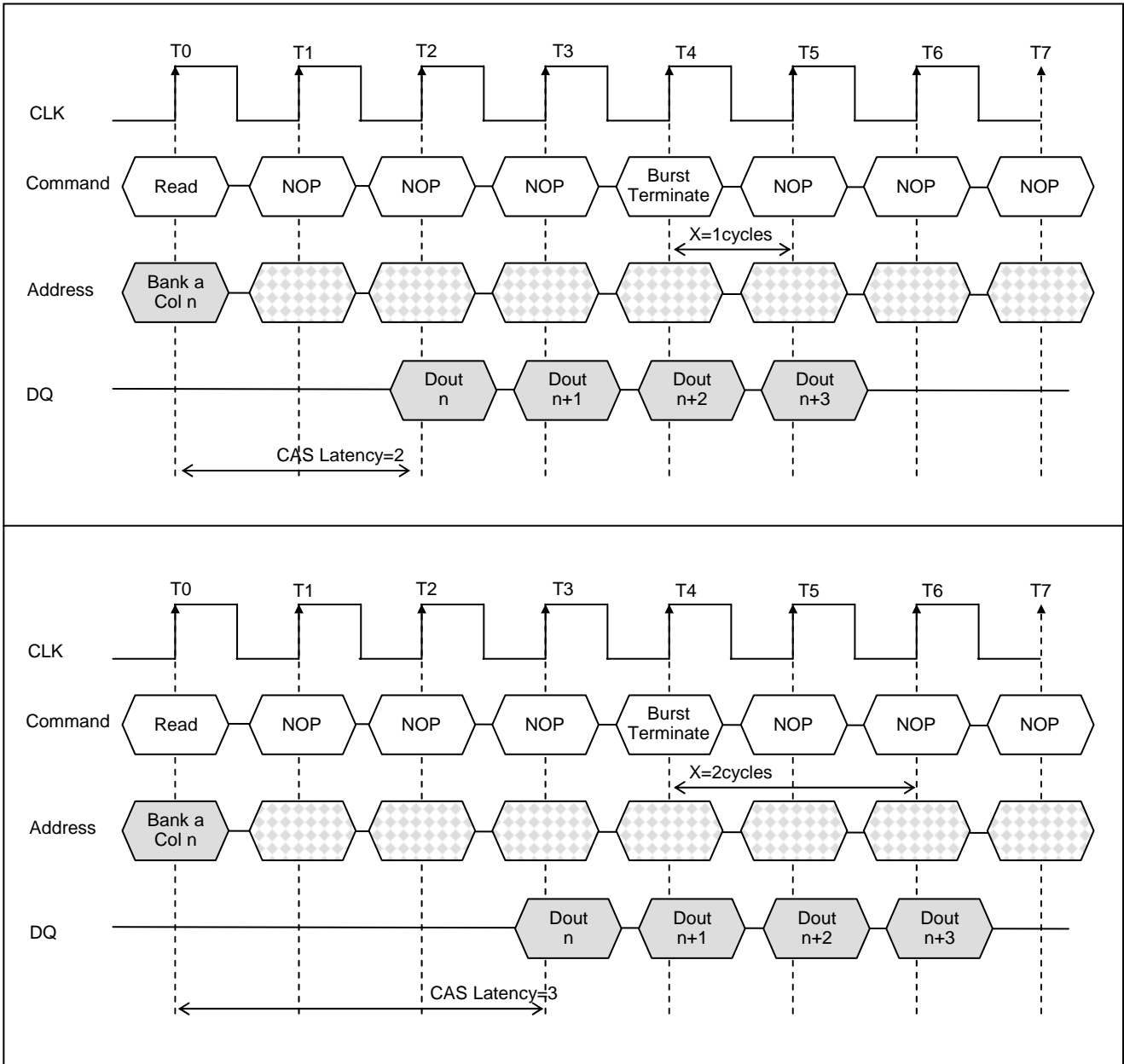
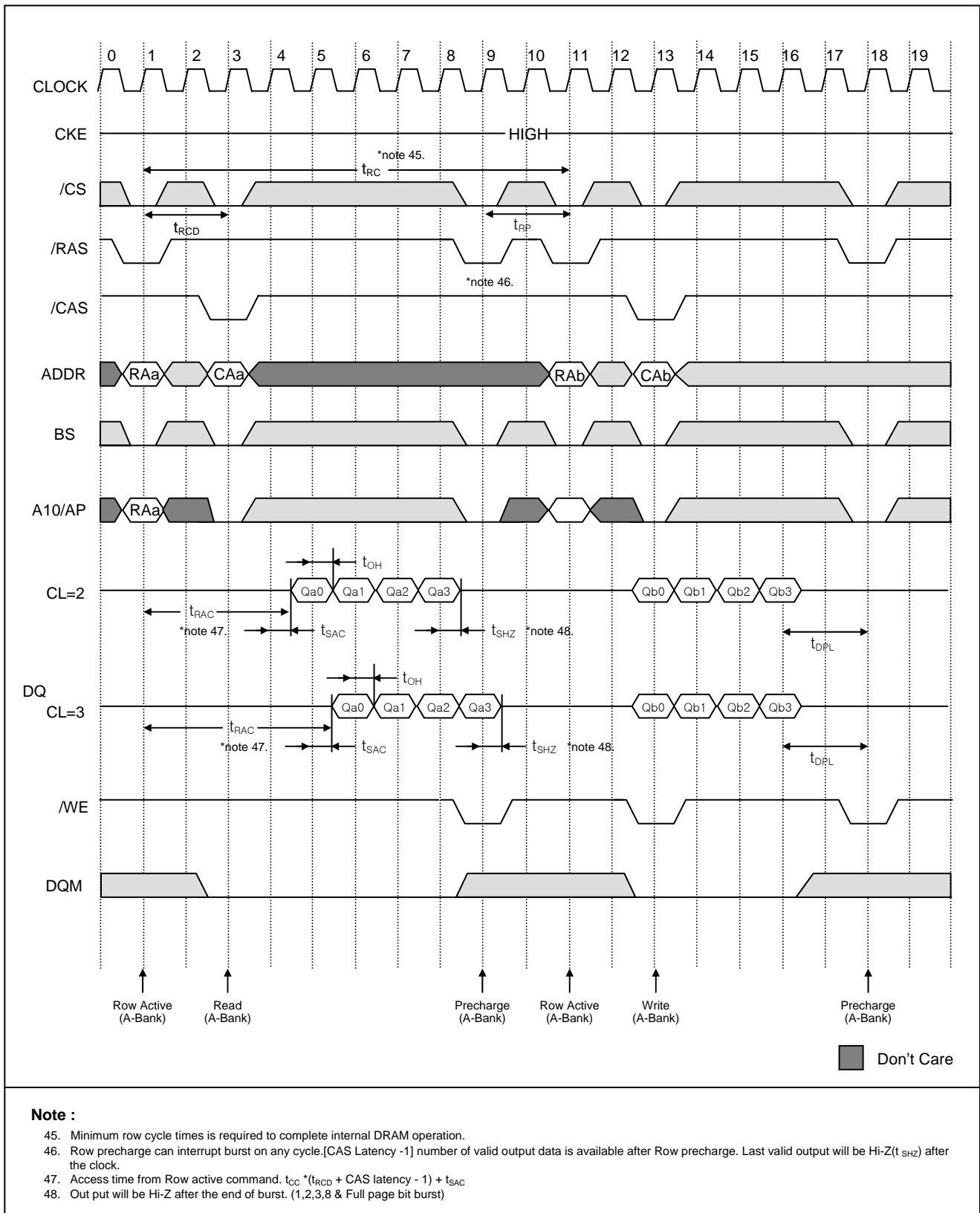

Figure 10. Terminating a Read Burst

Figure 11. Read & Write Cycle at Same Bank @Burst Length=4, $t_{DPL} = 2\text{CLK}$ (100Mhz)

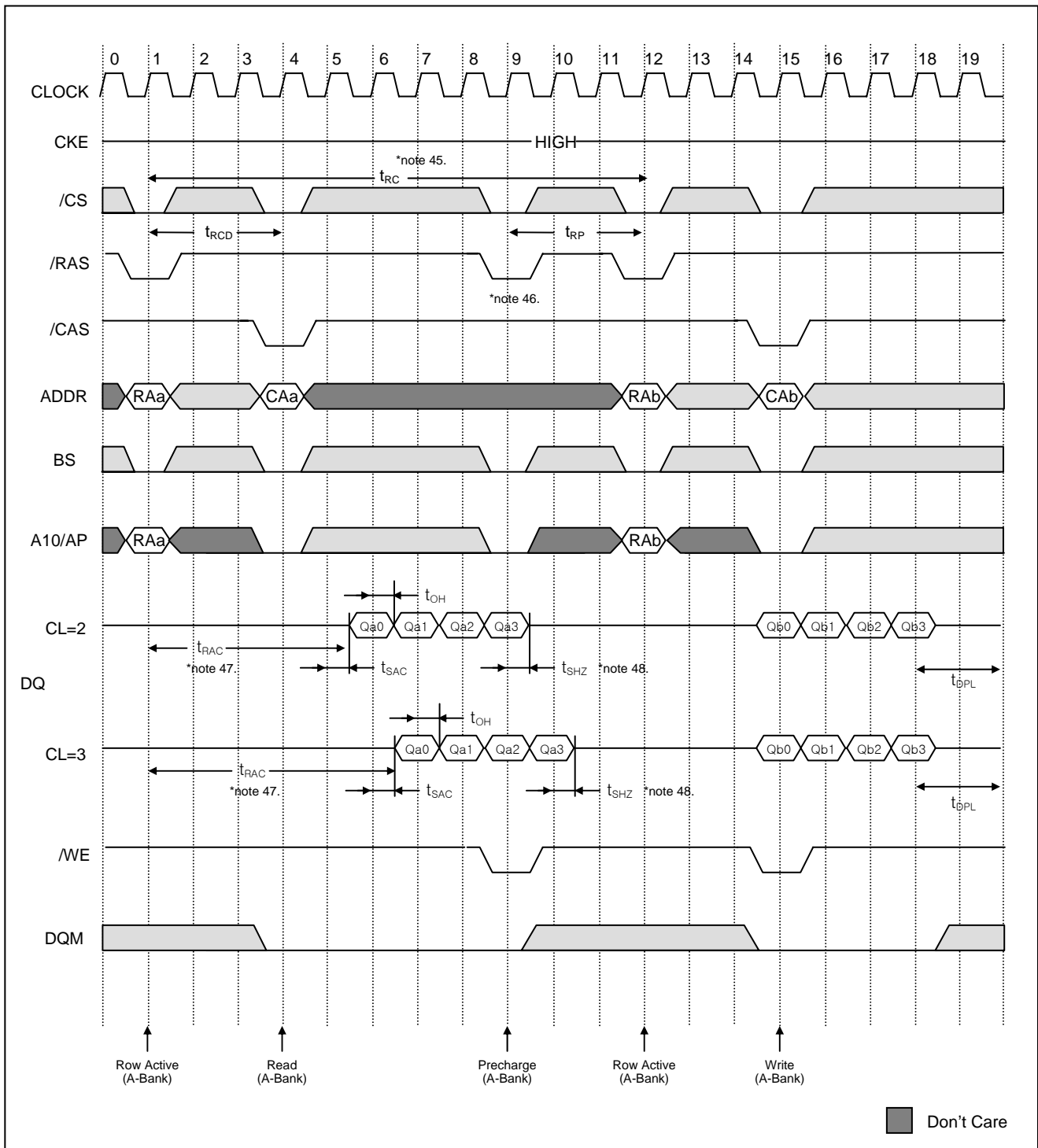

Figure 12. Read & Write Cycle at Same Bank @Burst Length=4, $t_{DPL}=2CLK$ (133Mhz)

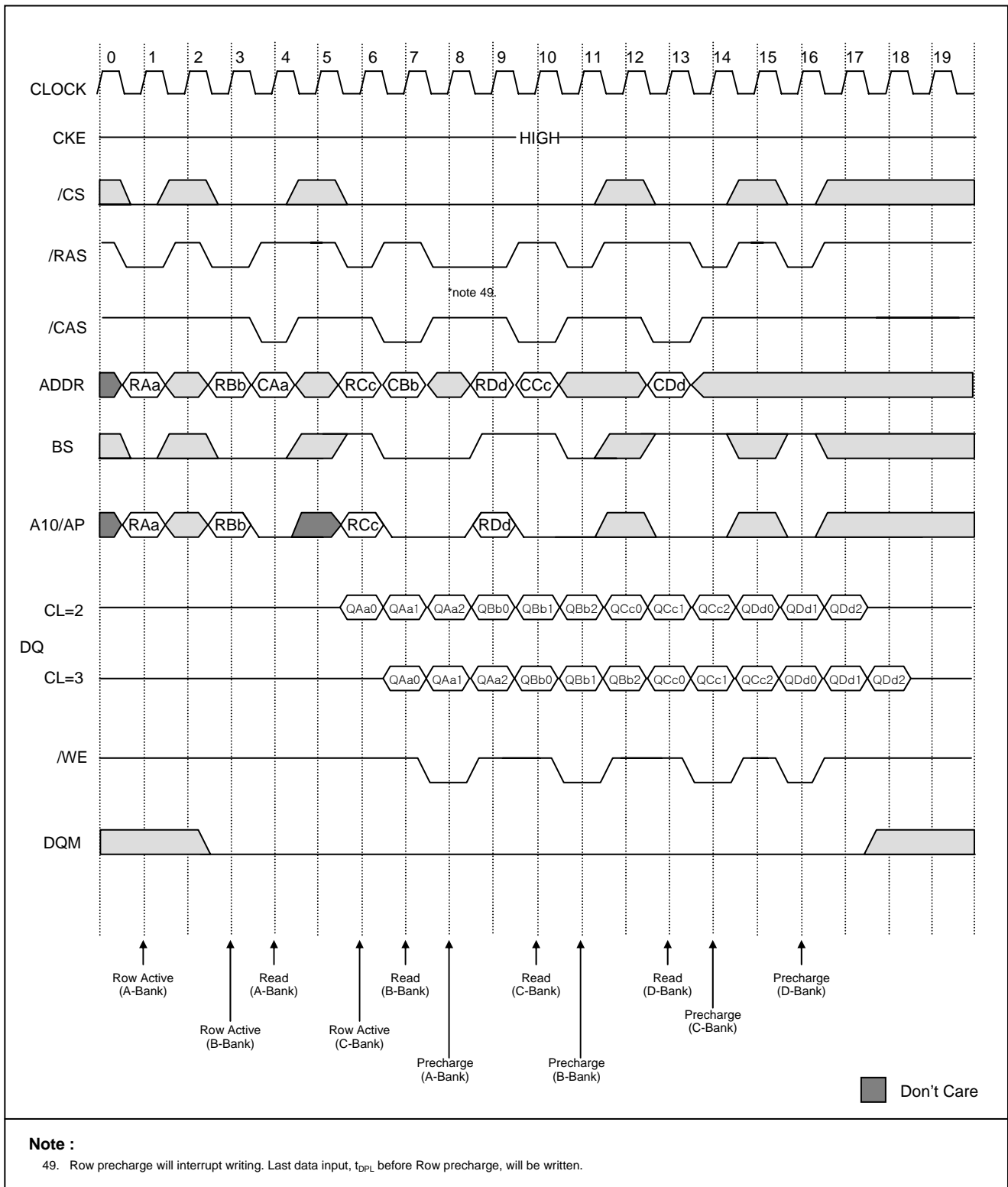

Figure 13. Page Read Cycle at Same Bank @ Burst Length=4

WRITE

WRITE bursts are initiated with a WRITE command, as shown

in Figure 14. The starting column and bank addresses are provided with the WRITE command, and auto precharge is

either enabled or disabled for that access. If auto precharge is enabled, the row being accessed is precharged at the completion of the burst. During WRITE bursts, the first valid data element will be registered coincident with the WRITE command. Subsequent data elements will be registered on each successive positive clock edge. Upon completion of a fixed-length burst, assuming no other commands have been initiated, the DQs will remain High-Z and any additional input data will be ignored (see Figure 15.). A fullpage burst will continue until

terminated. (wrap around at the end of the page) An example is shown in Figure 16. . Data $n + 1$ is either the last of a burst of two or the last desired of a longer burst.

A WRITE command can be initiated on any clock cycle following a previous WRITE command. Full-speed random write accesses within a page can be performed to the same bank, as shown in Figure 17. , or each subsequent WRITE may be performed to a different bank.

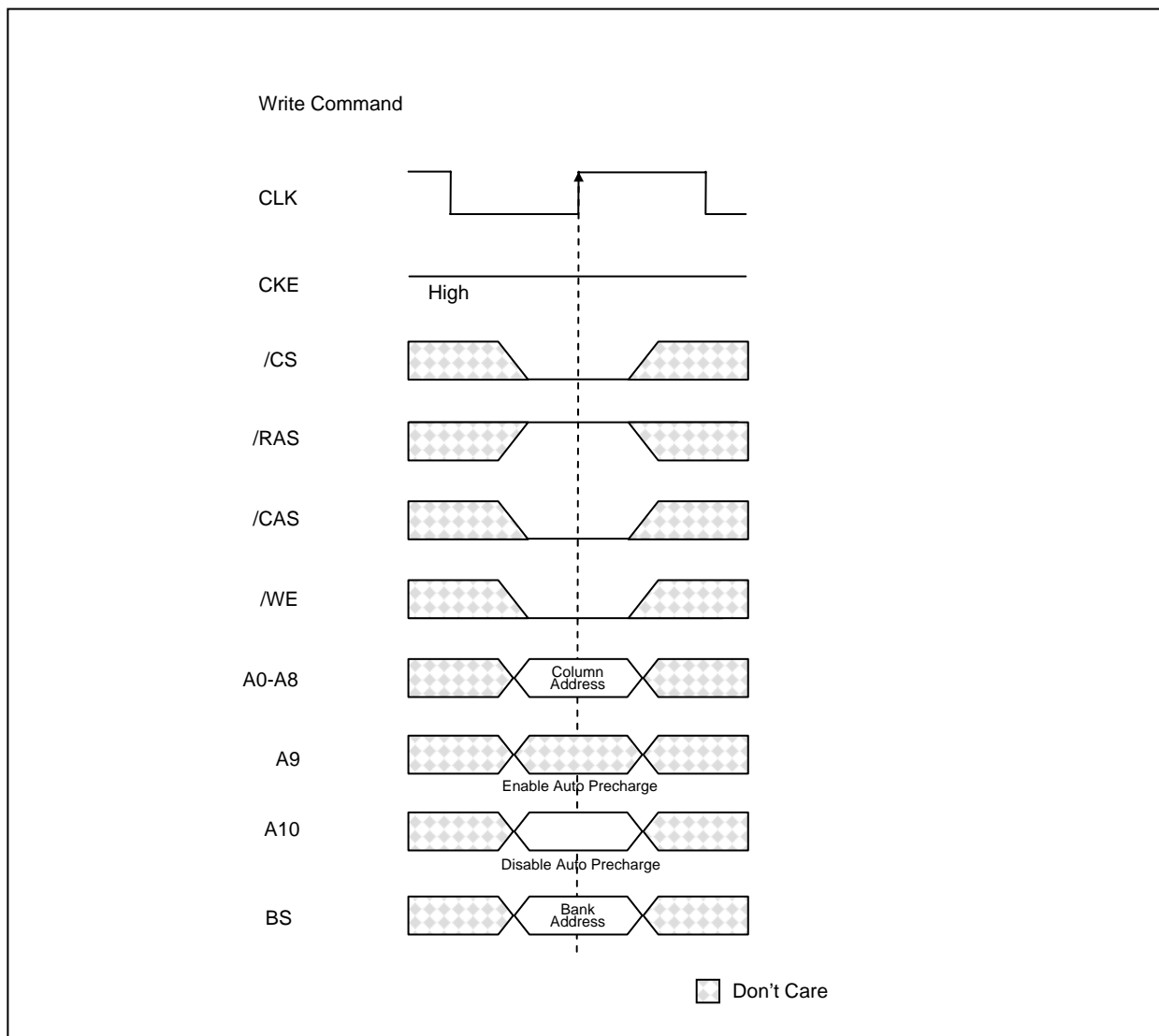

Figure 14. Write Command

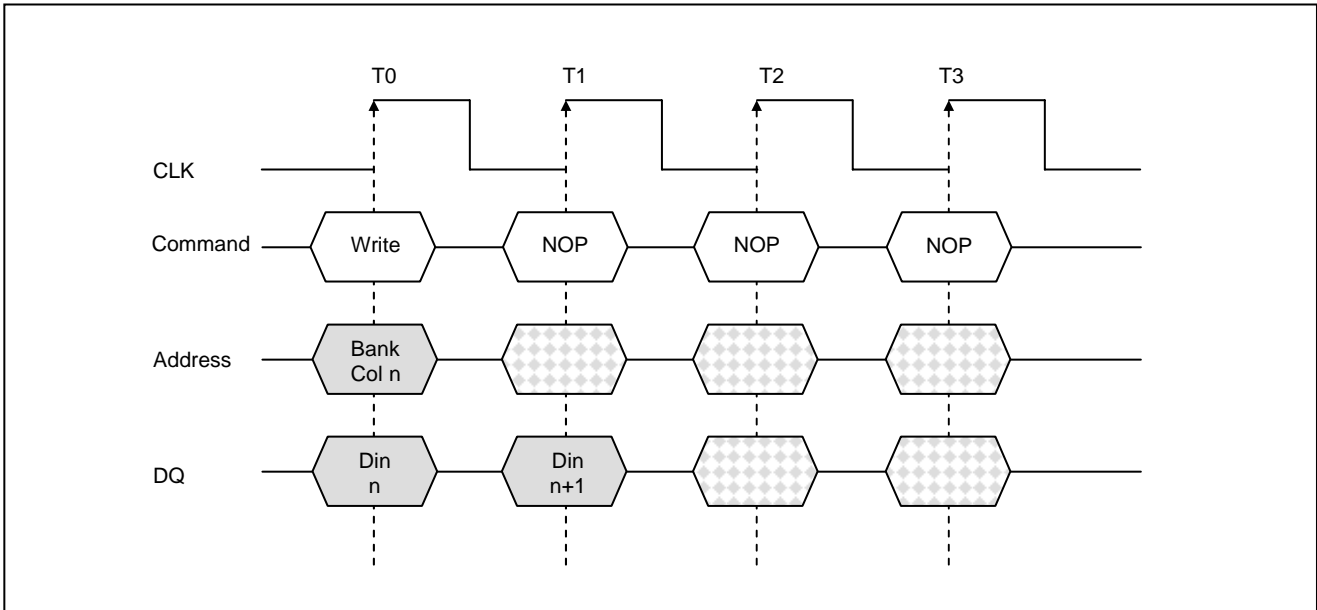

Figure 15. Write Burst - Burst length of 2

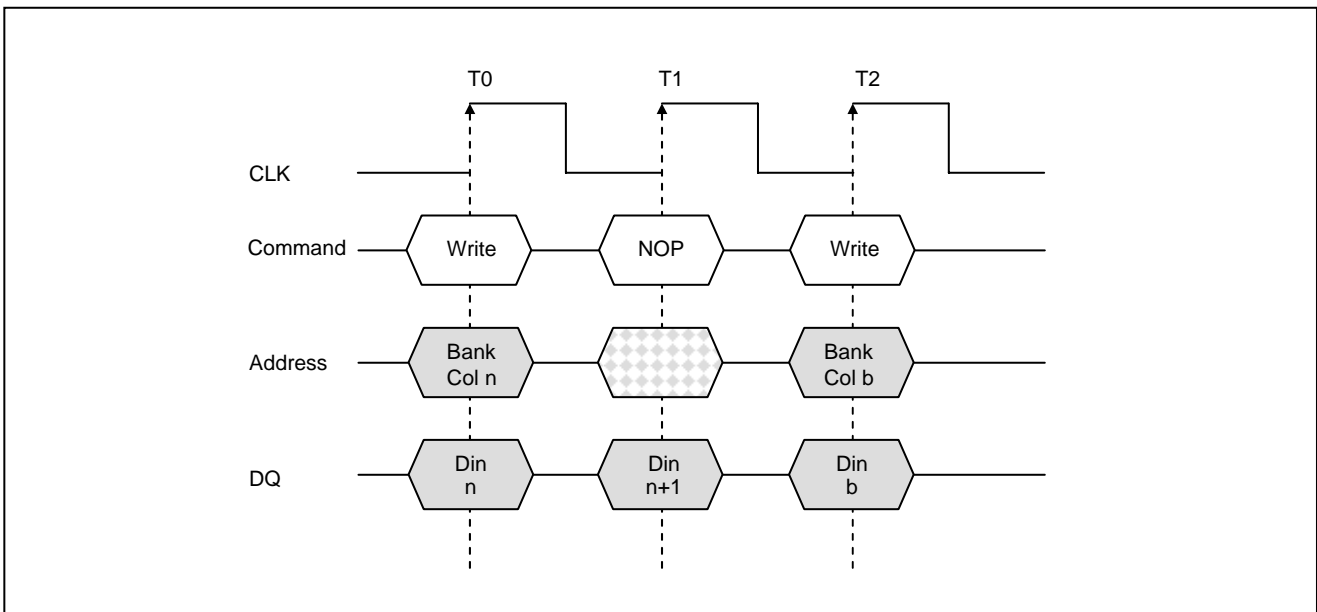

Figure 16. Write to Write - Transition from a burst of 2 to a single write

Data for a fixed-length WRITE burst a full-page WRITE burst may be followed by, or truncated with, a PRECHARGE command to the same bank. The PRECHARGE command should be issued t_{WR} after the clock edge at which the last desired input data element is registered. The auto precharge mode requires a t_{WR} of at least one clock plus time, regardless of frequency. In addition, when truncating a WRITE burst, the DQM signal must be used to mask input data for the clock edge

prior to, and the clock edge coincident with, the PRECHARGE command. An example is shown in Figure 19.

Data $n + 1$ is either the last of a burst of two or the last desired of a longer burst. Following the PRECHARGE command, a subsequent command to the same bank cannot be issued until t_{RP} is met.

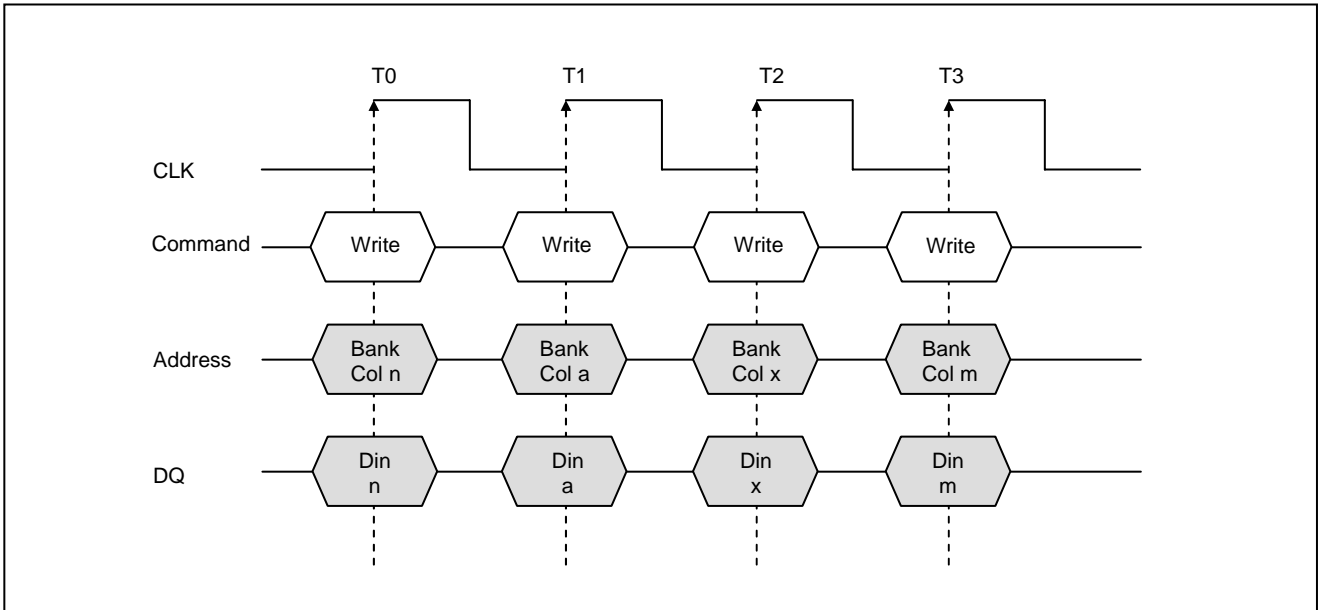

Figure 17. Random Write Cycles

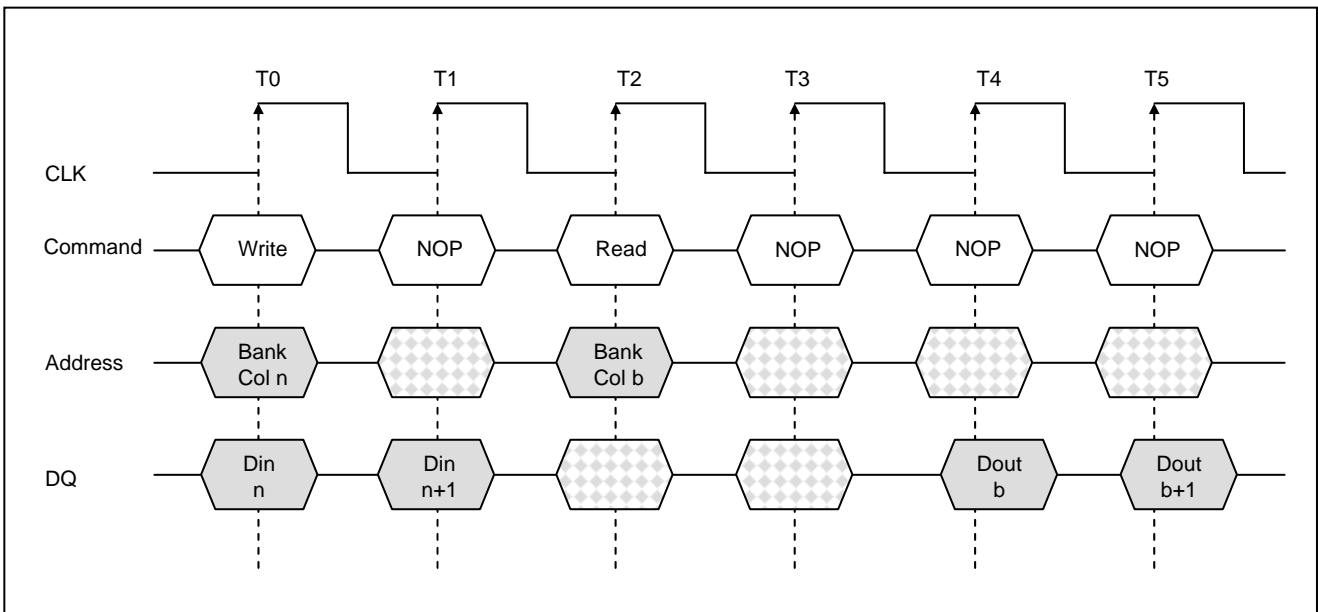

Figure 18. Write to Read Burst of 2 Write and Read(CAS Latency =2)

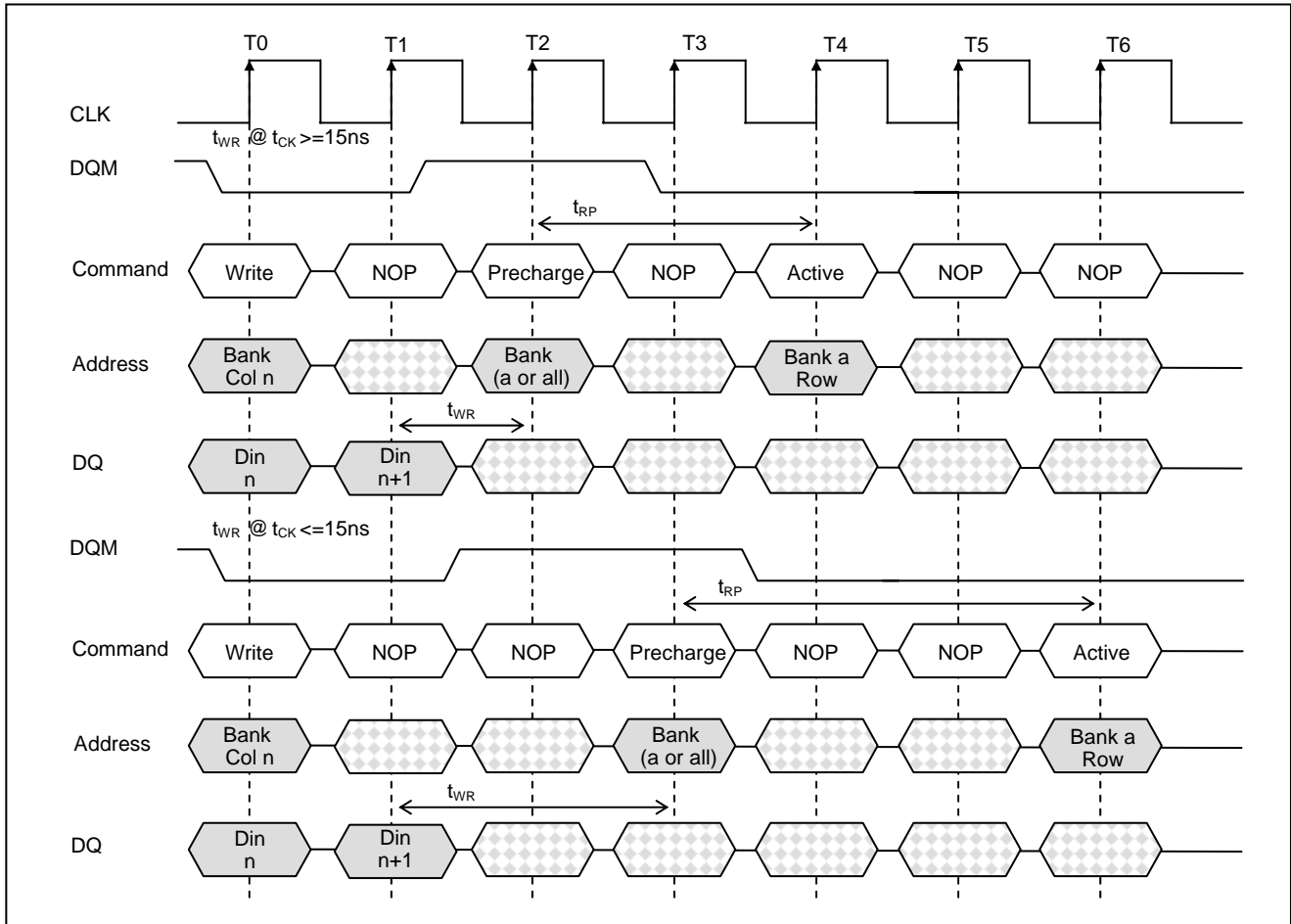

Figure 19. Write to Precharge

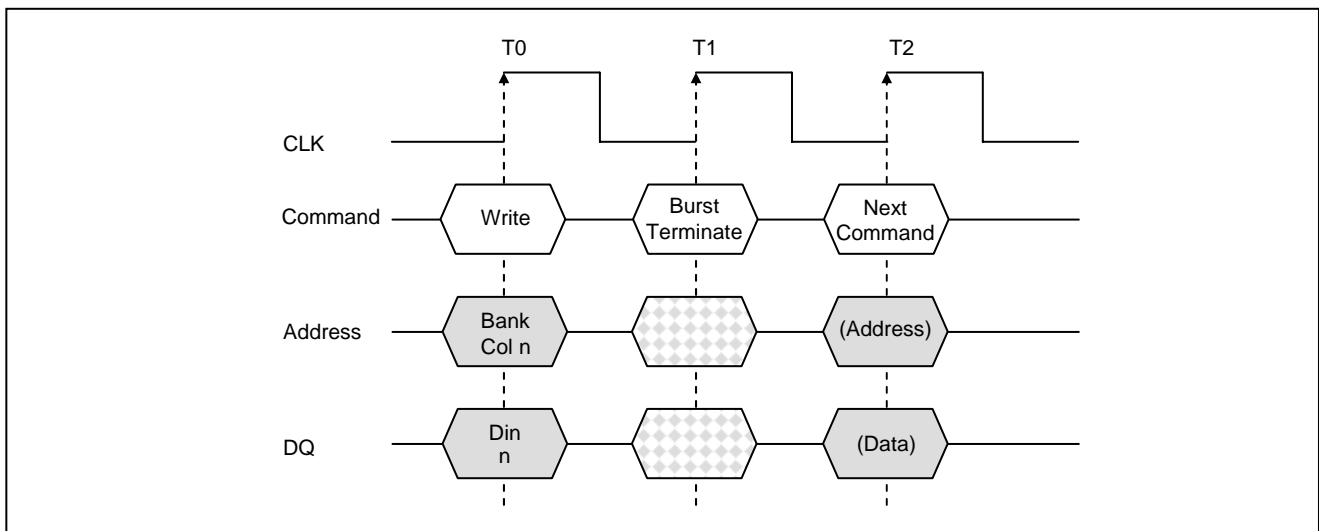

Figure 20. Terminating a Write Burst

Fixed-length or full-page WRITE bursts can be truncated with the BURST TERMINATE command. When truncating a WRITE burst, the input data applied coincident with the BURST

TERMINATE command will be ignored. The last data written (provided that DQM is LOW at that time) will be the input data applied one clock previous to the BURST TERMINATE

command. This is shown in Figure 20. , where data n is the last desired data element of a longer burst.

PRECHARGE

The PRECHARGE command (see Figure 21.) is used to deactivate the open row in a particular bank or the open row in all banks. The bank(s) will be available for a subsequent row access some specified time (t_{RP}) after the PRECHARGE command is issued. Input A10 determines whether one or all banks are to be precharged, and in the case where only one bank is to be precharged, inputs BS select the bank.

When all banks are to be precharged, inputs BS is treated as "Don't Care." Once a bank has been precharged, it is in the idle state and must be activated prior to any READ or WRITE commands being issued to that bank.

POWER-DOWN

Power-down occurs if CKE is registered LOW coincident with a NOP or COMMAND INHIBIT when no accesses are in progress. If power-down occurs when all banks are idle, this mode is referred to as precharge power-down; if power-down occurs when there is a row active in any bank, this mode is referred to as active power-down. Entering power-down deactivates the input and output buffers, excluding CKE, for maximum power savings while in standby. The device may not remain in the power-down state longer than the refresh period (64ms) since no refresh operations are performed in this mode. The power-down state is exited by registering a NOP or COMMAND INHIBIT and CKE HIGH at the desired clock edge(meeting t_{CKS}). See Figure 22. .

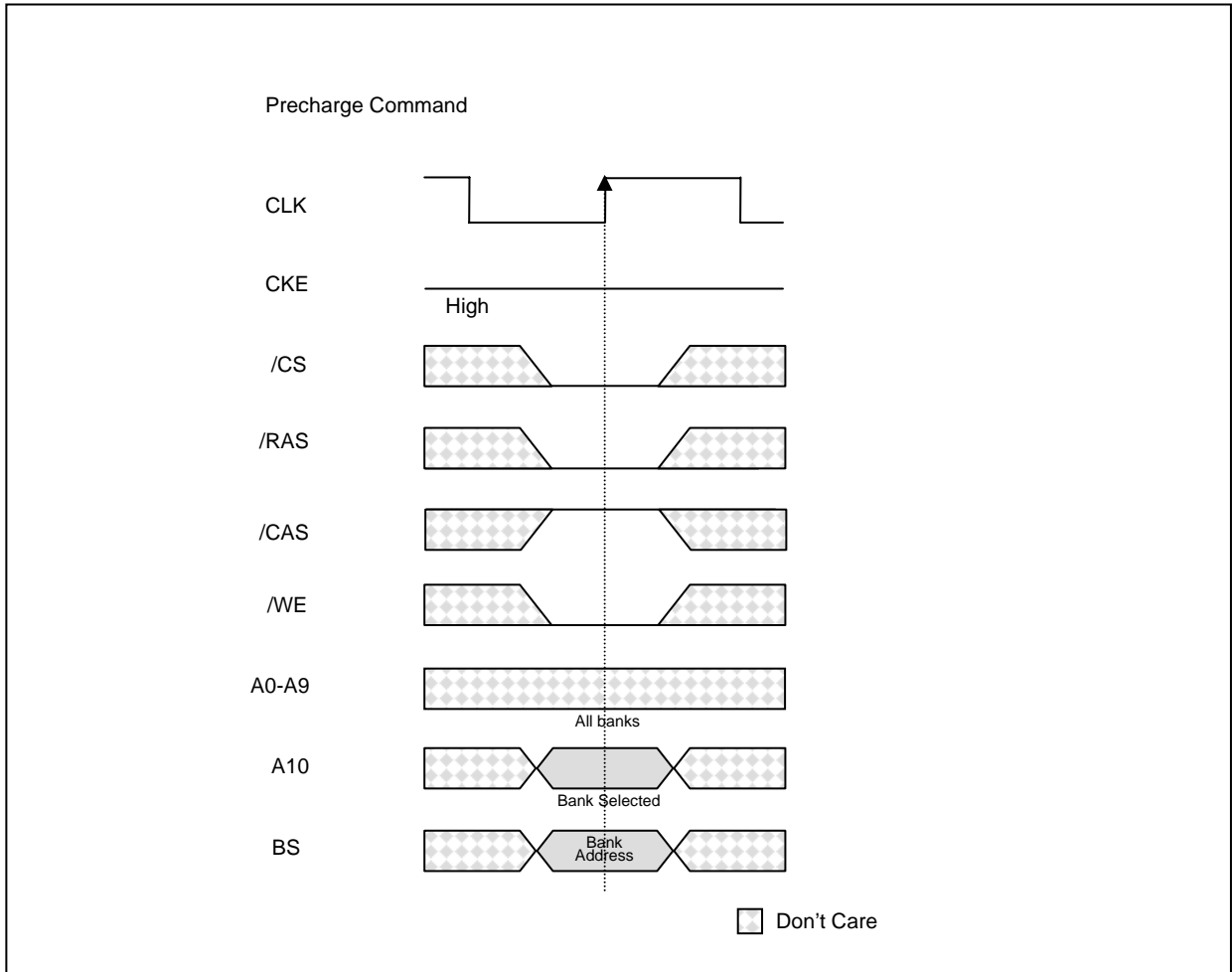

Figure 21. Precharge Command

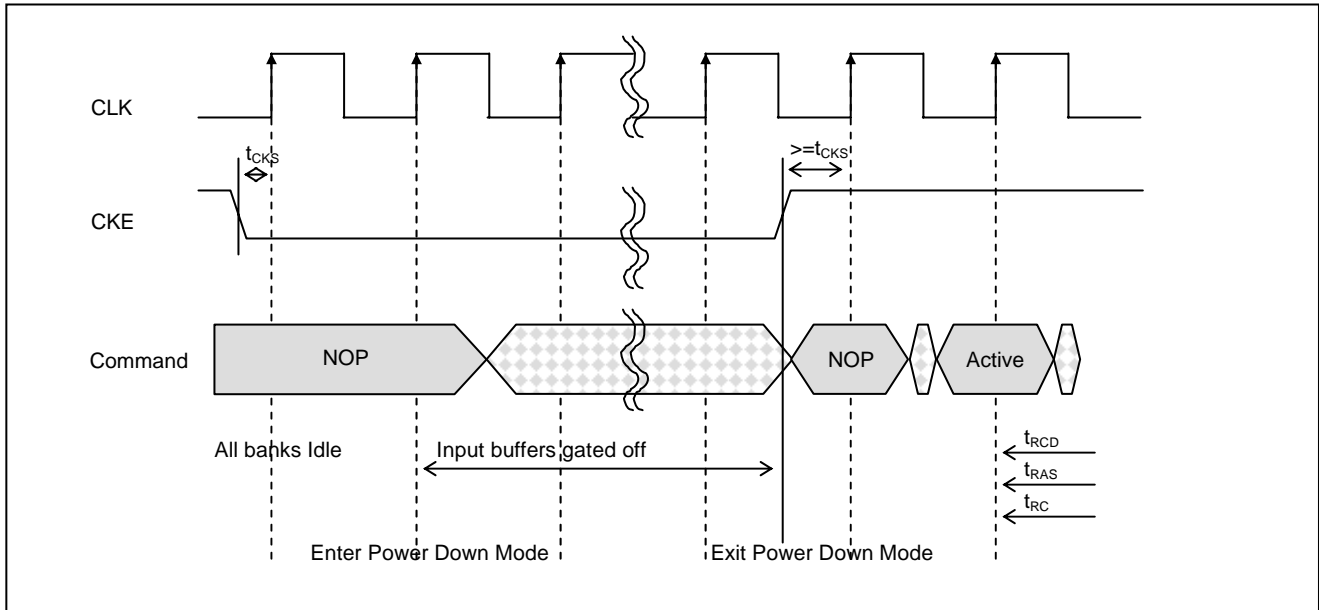

Figure 22. Power Down

CLOCK SUSPEND

The clock suspend mode occurs when a column access/burst is in progress and CKE is registered LOW. In the clock suspend mode, the internal clock is deactivated, “freezing” the synchronous logic. For each positive clock edge on which CKE is sampled LOW, the next internal positive clock edge is suspended. Any command or data present on the input pins at the time of a suspended internal clock edge is ignored; any data present on the DQ pins remains driven; and burst-counters are not incremented, as long as the clock is suspended. (See examples in Figure 23. and Figure 24. .) Clock

suspend mode is exited by registering CKE HIGH; the internal clock and related operation will resume on the subsequent positive clock edge.

BURST READ/SINGLE WRITE

In this mode, all WRITE commands result in the access of a single column location (burst of one), regardless of the programmed burst length. The burst read/single write mode is entered by programming the write burst mode bit (M9) in the mode register to a logic 1. READ commands access columns according to the programmed burst length and sequence.

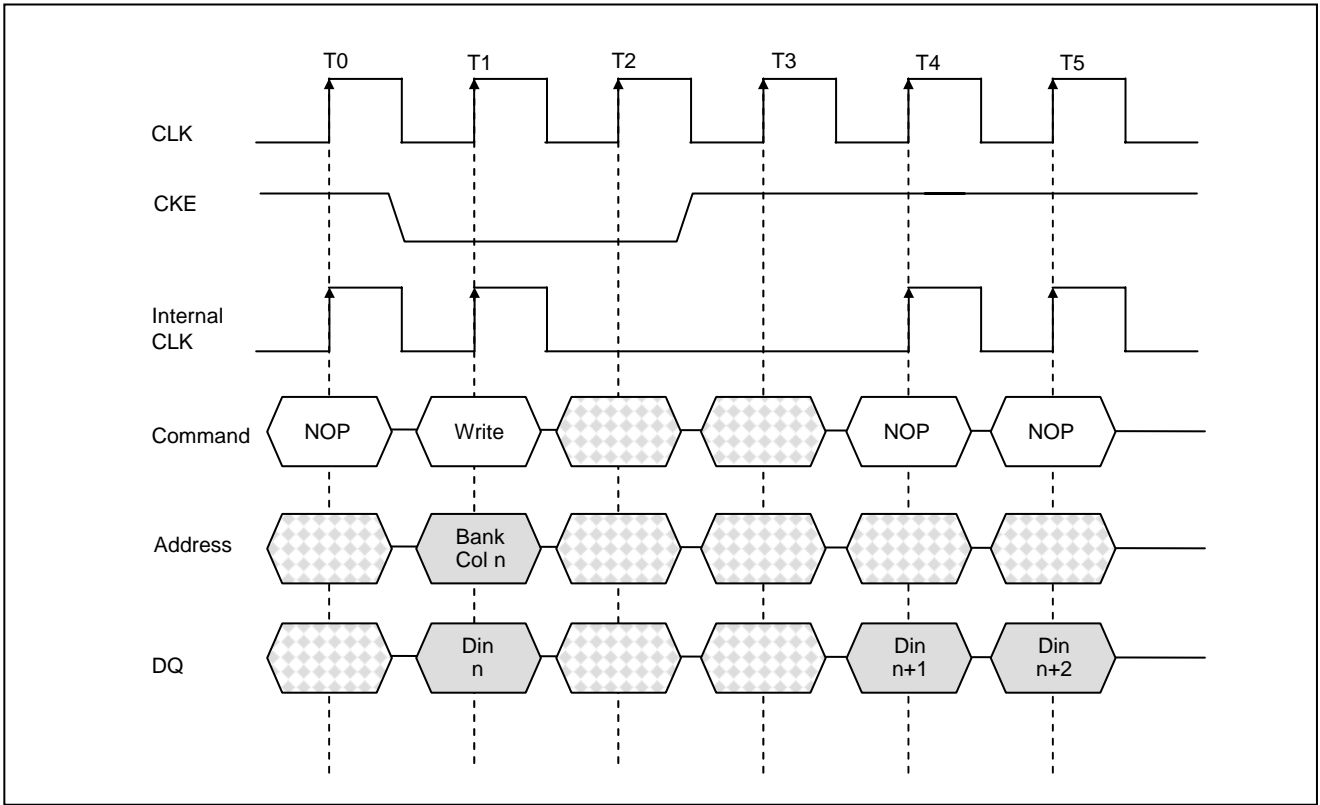

Figure 23. Clock Suspend During Write Burst

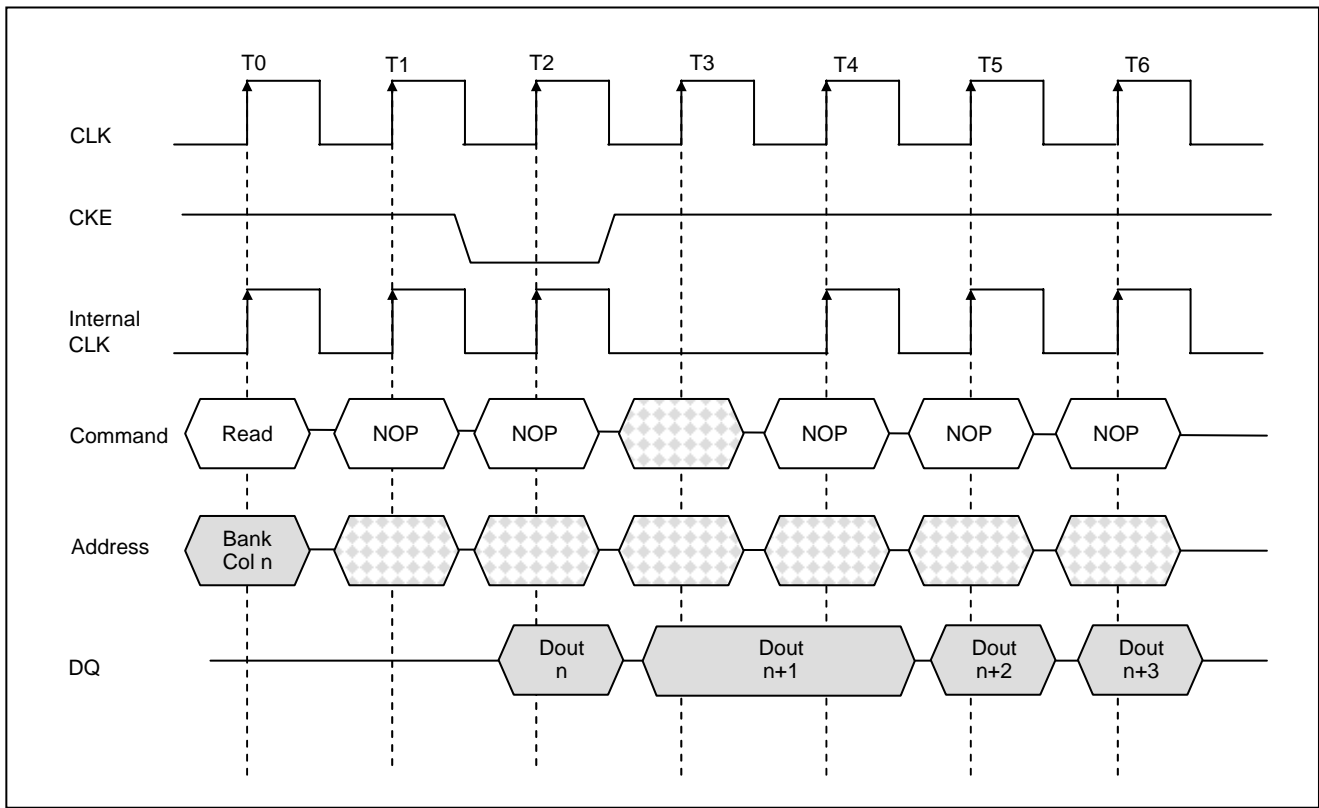

Figure 24. Clock Suspend During Read Burst - Burst of 4 (CAS latency =2)

Concurrent Auto Precharge

If an access command with Auto Precharge is being executed an access command (either a Read or Write) is not allowed by SDRAM's. If this feature is allowed then the SDRAM supports Concurrent Auto Precharge. Fidelix SDRAMs support Concurrent Auto Precharge. Four cases where Concurrent Auto Precharge occurs are defined below.

Read With Auto Precharge

1. Interrupted by a Read(with or without auto precharge): A read to bank m will interrupt a Read on bank n, CAS latency later. The precharge to bank n will begin when the Read to bank m is registered. (Figure 25.)
2. Interrupted by a Write(with or without auto precharge): A Write to bank m will interrupt a Read on bank n when registered.

DQM should be used two clocks prior to the Write command to prevent bus contention. The Precharge to bank n will begin when the write to bank m is registered. (Figure 26.)

Write with Auto Precharge

3. Interrupted by a Read(with or without auto precharge): A Read to bank m will interrupt a Write on bank n when registered , with the data-out appearing CAS latency later. The Precharge to bank n will begin after t_{WR} is met, where t_{WR} begins when the Read to bank m is registered. The last valid Write to bank n will be data-in registered one clock prior to the Read to bank m.(Figure 27.)
4. Interrupted by a Write (with or without auto Precharge): A Write to bank m will interrupt a Write on bank n when registered. The Precharge to bank n will begin after t_{WR} is met ,where t_{WR} begins when the Write to bank m is registered. The latest valid data Write to bank n will be data registered one clock prior to a Write to bank m.(Figure 28.)

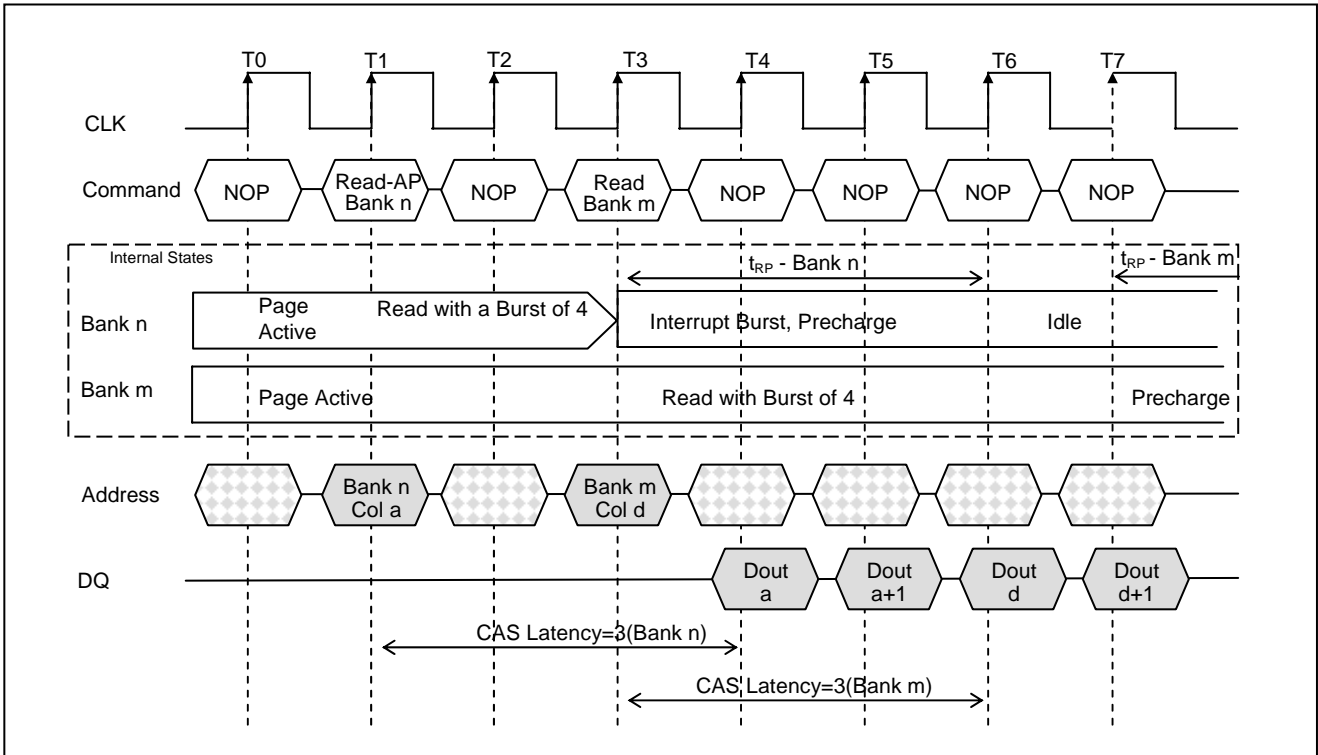

Figure 25. Read with Auto Precharge Interrupted by a Read(CAS Latency =3)

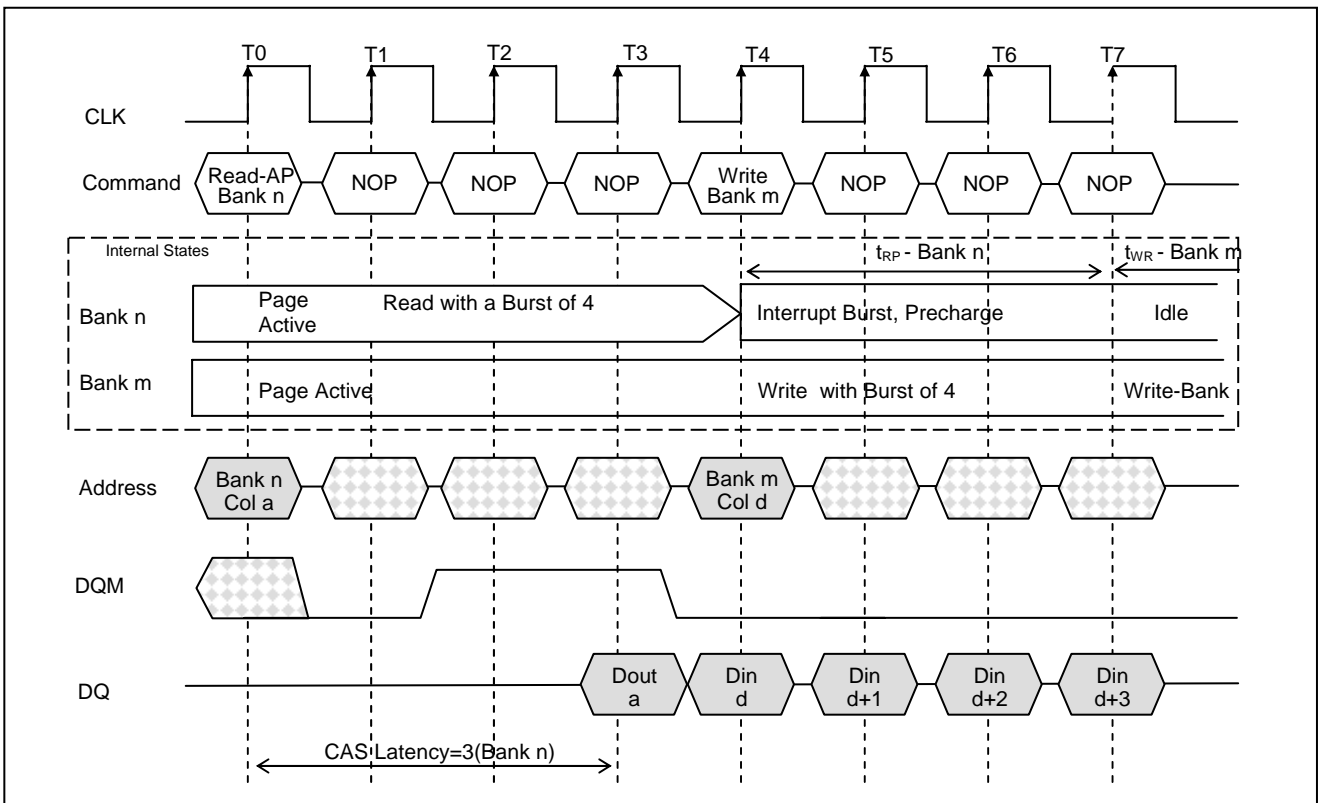

Figure 26. Read With Auto Precharge Interrupted by a Write(Read CAS Latency =3)

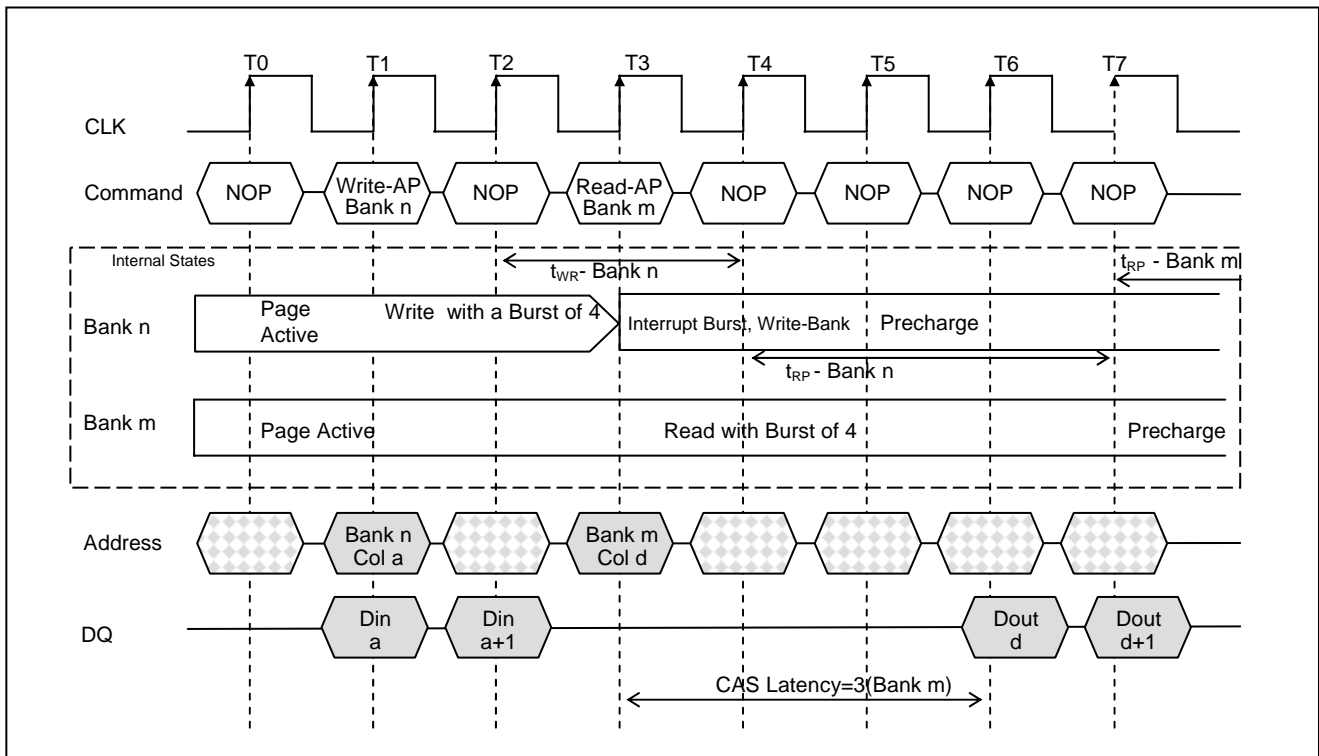

Figure 27. Write with Auto Precharge Interrupted by a Read with Auto Precharge (CAS Latency =3)

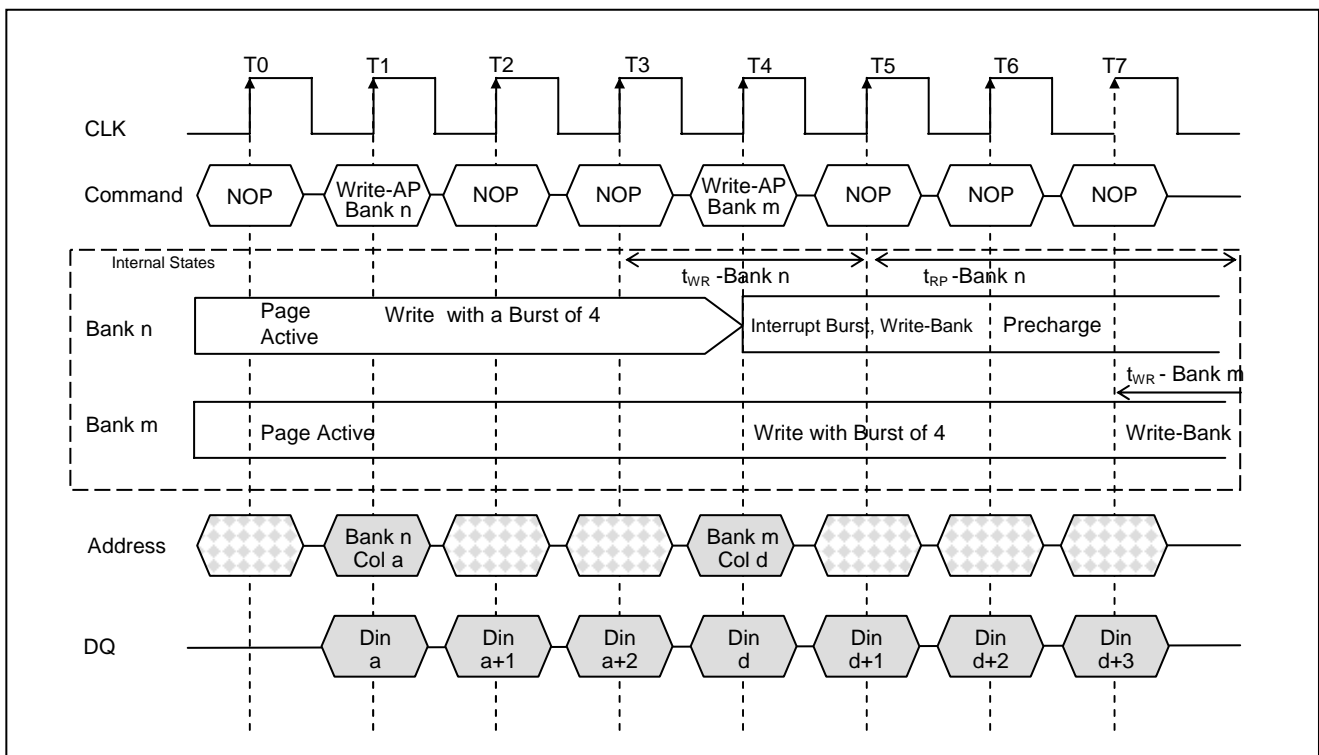

Figure 28. Write with Auto Precharge Interrupted by a Write with Auto Precharge

DEEP POWER DOWN MODE ENTRY

The Deep Power Down Mode is entered by having burst termination command, while CKE is low. The Deep Power Down Mode has to be maintained for a minimum of 100us.

The following diagram illustrates Deep Power Down mode entry.

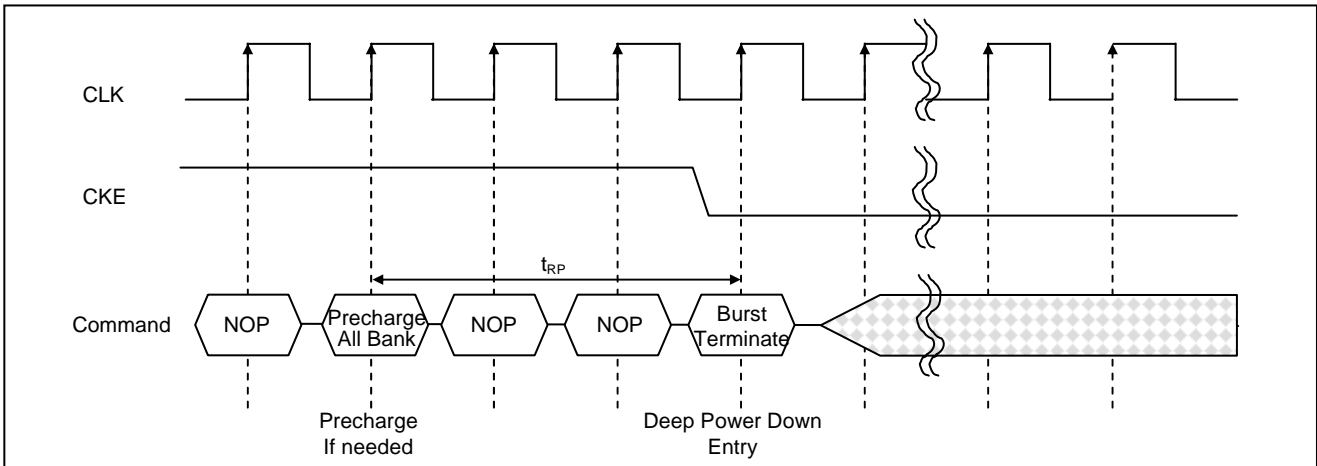

Figure 29. Deep Power Down Mode Entry

DEEP POWER DOWN MODE EXIT SEQUENCE

The Deep Power Down Mode is exited by asserting CKE high. After the exit, the following sequence is needed to enter a new command

1. Maintain NOP input conditions for a minimum of 200us
2. Issue precharge commands for all banks of the device
3. Issue 8 or more auto refresh commands
4. Issue a mode register set command to initialize the mode register
5. Issue a extended mode register set command to initialize the extended mode register

The following timing diagram illustrates deep power down exit sequence

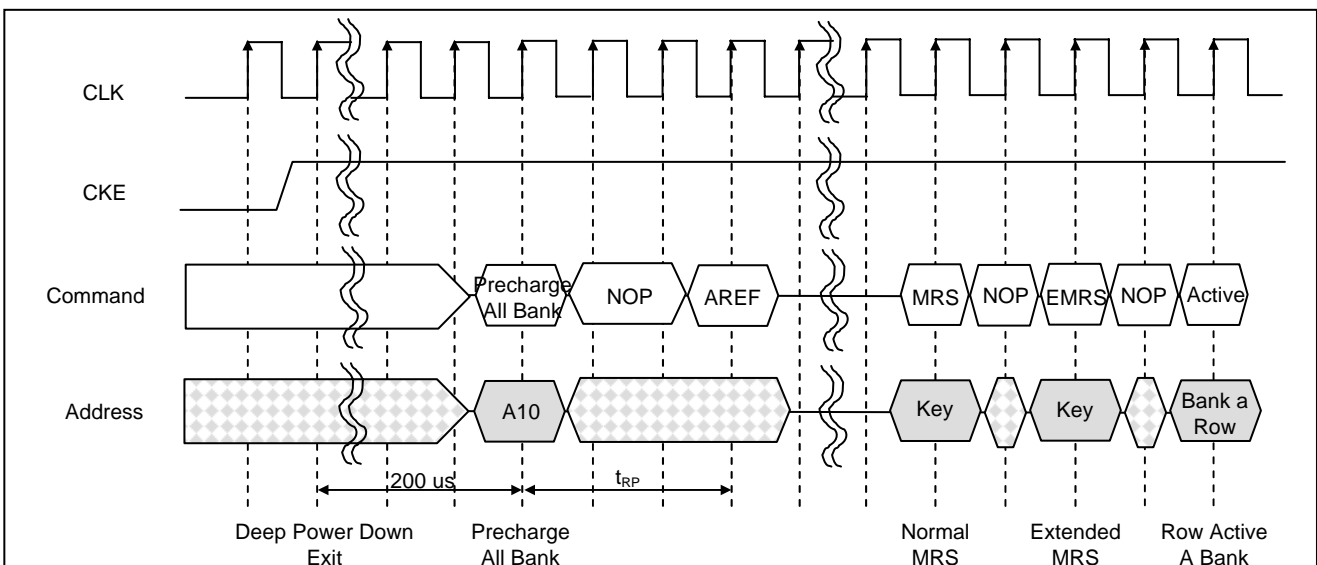

Figure 30. Deep Power Down Mode Exit

Table 9. CKE^[50.51.52.53] .

CKE _{n-1}	CKE _n	Current State	Command _n	Action _n
L	L	Power Down	X	Maintain Power Down
		Self Refresh	X	Maintain Self Refresh
		Clock Suspend	X	Maintain Clock Suspend
L	H	Power Down ^[54.] Self Refresh ^[55.]	Command Inhibit or NOP Command Inhibit or NOP	Exit Power Down Exit Self Refresh
		Clock Suspend ^[56.]	X	Exit Clock Suspend
H	L	All Banks Idle	Command Inhibit or NOP	Power Down Entry
		All Banks Idle Reading or Writing	Auto Refresh Valid	Self Refresh Entry Clock Suspend Entry
H	H		See Table 10.	

Note :

50. CKE_n is the logic state of CKE at clock edge n; CKE_{n-1} was the state of CKE at the previous clock edge.
51. Current State is the state of the SDRAM immediately prior to the clock edge n.
52. Command_n is the command registered at clock edge n , and Action_n is a result of Command_n.
53. All states and sequences not shown are illegal or reserved.
54. Exiting power down at clock edge n will put the device in all the banks idle state in time for clock edge n+1(provided the t_{CKS} is met)
55. Exiting self refresh at clock edge n will put the device in all the banks idle state once t_{XSR} is met. Command Inhibit or NOP commands should be issued on any clock edges occurring during the t_{XSR} period. A minimum of two NOP commands must be provided during the t_{XSR} period.
56. After exiting clock suspend at clock edge n, the device will resume operation and recognize the next command at clock edge n+1.

Table 10. Current State Bank n, Command to Bank n^[57.58.59.60.61.62] .

Current State	CS#	RAS#	CAS#	WE#	Command(Action)
Any	H	X	X	X	COMMAND INHIBIT (NOP/Continue previous operation)
	L	H	H	H	NO OPERATION (NOP/Continue previous operation)
Idle	L	L	H	H	ACTIVE (Select and activate row)
	L	L	L	H	AUTO REFRESH ^[63.]
	L	L	L	L	LOAD MODE REGISTER ^[63.]
	L	L	H	L	PRECHARGE ^[67.]

Note :

57. This table applies when CKE_{n-1} was HIGH and CKE_n is HIGH (see Table 9.) and after t_{XSR} has been met (if the previous state was self refresh).
58. This table is bank-specific, except where noted; i.e., the current state is for a specific bank and the commands shown are those allowed to be issued to that bank when in that state. Exceptions are covered in the notes below.
59. Current state definitions: Idle: The bank has been precharged, and t_{RP} has been met. Row Active: A row in the bank has been activated, and t_{RCD} has been met. No data bursts/accesses and no register accesses are in progress. Read: A READ burst has been initiated, with auto precharge disabled, and has not yet terminated or been terminated. Write: A WRITE burst has been initiated, with auto precharge disabled, and has not yet terminated or been terminated.
60. The following states must not be interrupted by a command issued to the same bank. COMMAND INHIBIT or NOP commands, or allowable commands to the other bank should be issued on any clock edge occurring during these states. Allowable commands to the other bank are determined by its current state and Table 10. and according to Table 11. . Precharging: Starts with registration of a PRECHARGE command and ends when t_{RP} is met. Once t_{RP} is met, the bank will be in the idle state. Row Activating: Starts with registration of an ACTIVE command and ends when t_{RCD} is met. Once t_{RCD} is met, the bank will be in the row active state. Read w/Auto Precharge Enabled: Starts with registration of a READ command with auto precharge enabled and ends when t_{RP} has been met. Once t_{RP} is met, the bank will be in the idle state. Write w/Auto Precharge Enabled: Starts with registration of a WRITE command with auto precharge enabled and ends when t_{RP} has been met. Once t_{RP} is met, the bank will be in the idle state.
61. The following states must not be interrupted by any executable command; COMMAND INHIBIT or NOP commands must be applied on each positive clock edge during these states. Refreshing: Starts with registration of an AUTO REFRESH command and ends when t_{RC} is met. Once t_{RC} is met, the SDRAM will be in the all banks idle state. Accessing Mode Register: Starts with registration of a LOAD MODE REGISTER command and ends when t_{MRD} has been met. Once t_{MRD} is met, the SDRAM will be in the all banks idle state. Precharging All: Starts with registration of a PRECHARGE ALL command and ends when t_{RP} is met. Once t_{RP} is met, all banks will be in the idle state.
62. All states and sequences not shown are illegal or reserved.
63. Not bank-specific; requires that all banks are idle.
64. May or may not be bank-specific; if all banks are to be precharged, all must be in a valid state for precharging.
65. Not bank-specific; BURST TERMINATE affects the most recent READ or WRITE burst, regardless of bank.
66. READs or WRITEs listed in the Command (Action) column include READs or WRITEs with auto precharge enabled and READs or WRITEs with auto precharge disabled.
67. Does not affect the state of the bank and acts as a NOP to that bank.

Table 10. Current State Bank n, Command to Bank n^[57.58.59.60.61.62.]

Current State	CS#	RAS#	CAS#	WE#	Command(Action)
Row Active	L	H	L	H	READ (Select column and start READ burst) ^[66.]
	L	H	L	L	WRITE (Select column and start WRITE burst) ^[66.]
	L	L	H	L	PRECHARGE (Deactivate row in bank or banks) ^[64.]
Read(Auto Precharge Disabled)	L	H	L	H	READ (Select column and start new READ burst) ^[66.]
	L	H	L	L	WRITE (Select column and start WRITE burst) ^[66.]
	L	L	H	L	PRECHARGE (Truncate READ burst, start RECHARGE) ^[64.]
	L	H	H	L	BURST TERMINATE ^[65.]
Write (Auto Precharge Disabled)	L	H	L	H	READ (Select column and start READ burst) ^[66.]
	L	H	L	L	WRITE (Select column and start new WRITE burst) ^[66.]
	L	L	H	L	PRECHARGE (Truncate WRITE burst, start PRECHARGE) ^[64.]
	L	H	H	L	BURST TERMINATE ^[65.]

Table 11. Current State Bank n, Command to Bank m^[68.69.70.71.72.73.]

Current State	CS#	RAS#	CAS#	WE#	Command(Action)
Any	H	X	X	X	COMMAND INHIBIT (NOP/Continue previous operation)
	L	H	H	H	NO OPERATION (NOP/Continue previous operation)
Idle	X	X	X	X	Any Command Otherwise Allowed to Bank <i>m</i>
Row Activating, Active, or Precharging	L	L	H	H	ACTIVE (Select and activate row)
	L	H	L	H	READ (Select column and start READ burst) ^[74.]
	L	H	L	L	WRITE (Select column and start WRITE burst) ^[74.]
	L	L	H	L	PRECHARGE
Read(Auto Precharge Disabled)	L	L	H	H	ACTIVE (Select and activate row)
	L	H	L	H	READ (Select column and start new READ burst) ^[74.78.]
	L	H	L	L	WRITE (Select column and start WRITE burst) ^[74.79.]
	L	L	H	L	PRECHARGE ^[76.]
Write(Auto Precharge Disabled)	L	L	H	H	ACTIVE (Select and activate row)
	L	H	L	H	READ (Select column and start READ burst) ^[74.79.]
	L	H	L	L	WRITE (Select column and start new WRITE burst) ^[76.80.]
	L	L	H	L	PRECHARGE ^[76.]

Table 11. Current State Bank n, Command to Bank m^[68.69.70.71.72.73.] .

Current State	CS#	RAS#	CAS#	WE#	Command(Action)
Read (With Auto Precharge)	L	L	H	L	ACTIVE (Select and activate row)
	L	H	L	H	READ (Select column and start new READ burst) ^[74.75.81.]
	L	H	L	L	WRITE (Select column and start WRITE burst) ^[74.75.82.]
	L	L	H	L	PRECHARGE ^[76.]
Write (With Auto Precharge)	L	L	H	H	ACTIVE (Select and activate row)
	L	H	L	H	READ (Select column and start READ burst) ^[74.75.83.]
	L	H	L	L	WRITE (Select column and start new WRITE burst) ^[74.75.84.]
	L	L	H	L	PRECHARGE ^[76.]

Note :

68. This table applies when CKE_{n-1} was HIGH and CKE_n is HIGH and after t_{XSR} has been met (if the previous state was self refresh).
69. This table describes alternate bank operation, except where noted; i.e., the current state is for bank n and the commands shown are those allowed to be issued to bank m (assuming that bank m is in such a state that the given command is allowable). Exceptions are covered in the notes below.
70. Current state definitions: Idle: The bank has been precharged, and t_{RP} has been met. Row Active: A row in the bank has been activated, and t_{RCD} has been met. No data bursts/accesses and no register accesses are in progress. Read: A READ burst has been initiated, with auto precharge disabled, and has not yet terminated or been terminated. Write: A WRITE burst has been initiated, with auto precharge disabled, and has not yet terminated or been terminated.
Read w/Auto Precharge Enabled: Starts with registration of a READ command with auto precharge enabled, and ends when t_{RP} has been met. Once t_{RP} is met, the bank will be in the idle state. Write w/Auto Precharge Enabled: Starts with registration of a WRITE command with auto precharge enabled, and ends when t_{RP} has been met. Once t_{RP} is met, the bank will be in the idle state.
71. AUTO REFRESH, SELF REFRESH and LOAD MODE REGISTER commands may only be issued when all banks are idle.
72. A BURST TERMINATE command cannot be issued to another bank; it applies to the bank represented by the current state only.
73. All states and sequences not shown are illegal or reserved.
74. READs or WRITEs to bank m listed in the Command (Action) column include READs or WRITEs with auto precharge enabled and READs or WRITEs with auto precharge disabled.
75. CONCURRENT AUTO PRECHARGE: Bank n will initiate the auto precharge command when its burst has been interrupted by bank m 's burst.
76. Burst in bank n continues as initiated.
77. For a READ without auto precharge interrupted by a READ (with or without auto precharge), the READ to bank m will interrupt the READ on bank n , CAS latency later.
78. For a READ without auto precharge interrupted by a WRITE (with or without auto precharge), the WRITE to bank m will interrupt the READ on bank n when registered. DQM should be used two clock prior to the WRITE command to prevent bus contention.
79. For a WRITE without auto precharge interrupted by a READ (with or without auto precharge), the READ to bank m will interrupt the WRITE on bank n when registered, with the data-out appearing CAS latency later. The last valid WRITE to bank n will be data-in registered one clock prior to the READ to bank m .
80. For a WRITE without auto precharge interrupted by a WRITE (with or without auto precharge), the WRITE to bank m will interrupt the WRITE on bank n when registered. The last valid WRITE to bank n will be data-in registered one clock prior to the READ to bank m .
81. For a READ with auto precharge interrupted by a READ (with or without auto precharge), the READ to bank m will interrupt the READ on bank n , CAS latency later. The PRECHARGE to bank n will begin when the READ to bank m is registered (Figure 25.).
82. For a READ with auto precharge interrupted by a WRITE (with or without auto precharge), the WRITE to bank m will interrupt the READ on bank n when registered. DQM should be used two clocks prior to the WRITE command to prevent bus contention. The PRECHARGE to bank n will begin when the WRITE to bank m is registered (Figure 26.).
83. For a WRITE with auto precharge interrupted by a READ (with or without auto precharge), the READ to bank m will interrupt the WRITE on bank n when registered, with the data-out appearing CAS latency later. The PRECHARGE to bank n will begin after t_{WR} is met, where t_{WR} begins when the READ to bank m is registered. The last valid WRITE to bank n will be data-in registered one clock prior to the READ to bank m (Figure 27.).
84. For a WRITE with auto precharge interrupted by a WRITE (with or without auto precharge), the WRITE to bank m will interrupt the WRITE on bank n when registered. The PRECHARGE to bank n will begin after t_{WR} is met, where t_{WR} begins when the WRITE to bank m is registered. The last valid WRITE to bank n will be data registered one clock prior to the WRITE to bank m (Figure 28.).

PACKAGE DIMENSION

Unit : millimeters

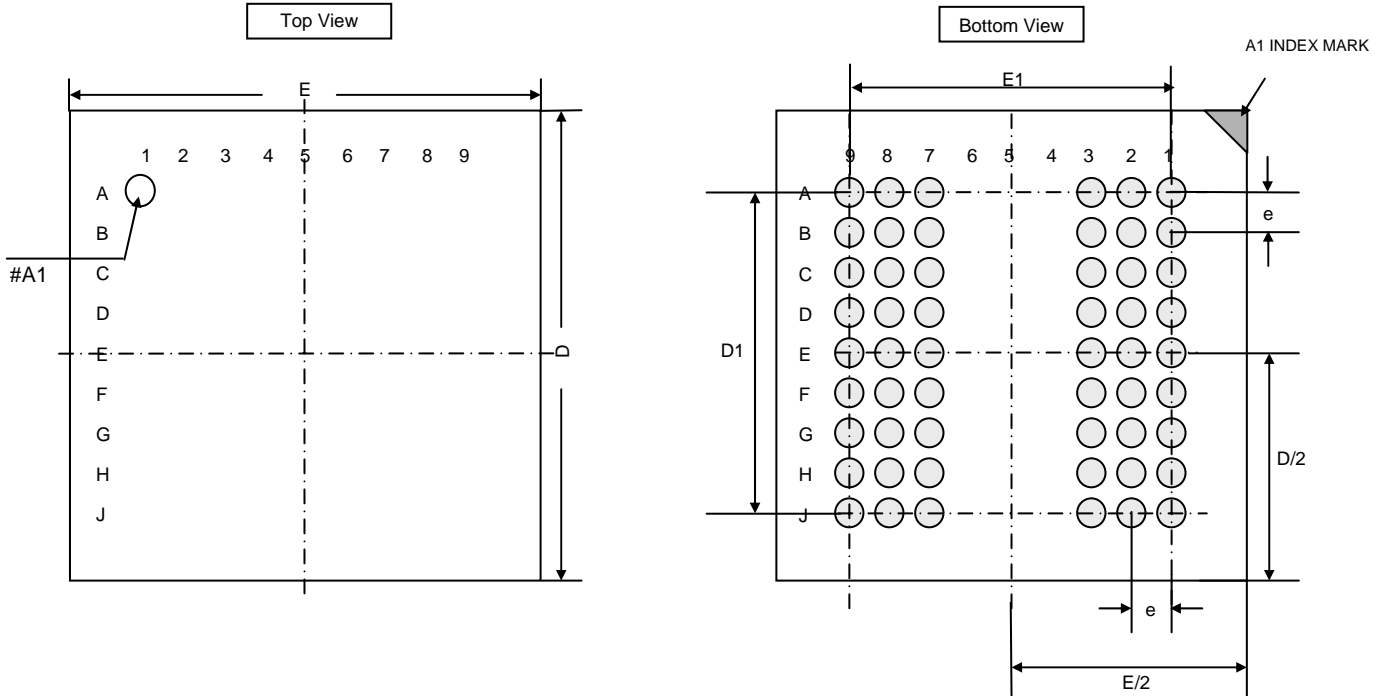
54 BALL FINE PITCH BGA (8 x 8 x 1.0 mm)

Unit : mm

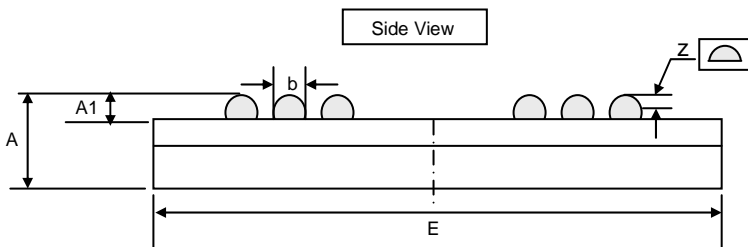

-	Min	Typ	Max
A	-	-	1.20
A1	0.30	0.35	0.40
E	-	8.00	-
E1	-	6.40	-
D	-	8.00	-
D1	-	6.40	-
e	-	0.80	-
b	0.40	0.45	0.50
z	-	-	0.10