

## Voltage Transducer LV 100-500

$$V_{PN} = 500 \text{ V}$$

For the electronic measurement of voltages : DC, AC, pulsed..., with a galvanic isolation between the primary circuit (high voltage) and the secondary circuit (electronic circuit).

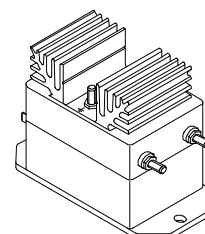

### Electrical data

$V_{PN}$	Primary nominal r.m.s. voltage	500	V			
$V_P$	Primary voltage, measuring range	0 .. $\pm 750$	V			
$I_{PN}$	Primary nominal r.m.s. current	20	mA			
$R_M$	Measuring resistance	$R_{Mmin}$	$R_{Mmax}$			
		with $\pm 15 \text{ V}$	@ $\pm 500 \text{ V}_{max}$	0	170	$\Omega$
			@ $\pm 750 \text{ V}_{max}$	0	90	$\Omega$
$I_{SN}$	Secondary nominal r.m.s. current	50	mA			
$K_N$	Conversion ratio	500 V / 50 mA				
$V_C$	Supply voltage ( $\pm 5 \%$ )	$\pm 15$	V			
$I_C$	Current consumption	$10 + I_s$	mA			
$V_d$	R.m.s. voltage for AC isolation test, 50 Hz, 1 mn	6	kV			

### Features

- Closed loop (compensated) voltage transducer using the Hall effect
- Insulated plastic case recognized according to UL 94-V0
- Primary resistor  $R_1$  incorporated into the housing.

### Advantages

- Excellent accuracy
- Very good linearity
- Low thermal drift
- High immunity to external interference.

### Applications

- AC variable speed drives and servo motor drives
- Static converters for DC motor drives
- Uninterruptible Power Supplies (UPS)
- Power supplies for welding applications.

### Accuracy - Dynamic performance data

$X_G$	Overall Accuracy @ $V_{PN}$ , $T_A = 25^\circ\text{C}$	$\pm 0.7$	%
$e_L$	Linearity	$< 0.1$	%
$I_O$	Offset current @ $I_P = 0$ , $T_A = 25^\circ\text{C}$	Typ	Max
$I_{OT}$	Thermal drift of $I_O$	$\pm 0.2$	$\pm 0.3$
$t_r$	Response time @ 90 % of $V_{PN}$	90	$\mu\text{s}$

### General data

$T_A$	Ambient operating temperature	0 .. +70	$^\circ\text{C}$
$T_S$	Ambient storage temperature	-25 .. +85	$^\circ\text{C}$
$N$	Turns ratio	5000 : 2000	
$P$	Total primary power loss	10	W
$R_1$	Primary resistance @ $T_A = 25^\circ\text{C}$	25	k $\Omega$
$R_S$	Secondary coil resistance @ $T_A = 70^\circ\text{C}$	60	$\Omega$
$m$	Mass	850	g
	Standards	EN 50178	

## Dimensions LV 100-500 (in mm. 1 mm = 0.0394 inch)

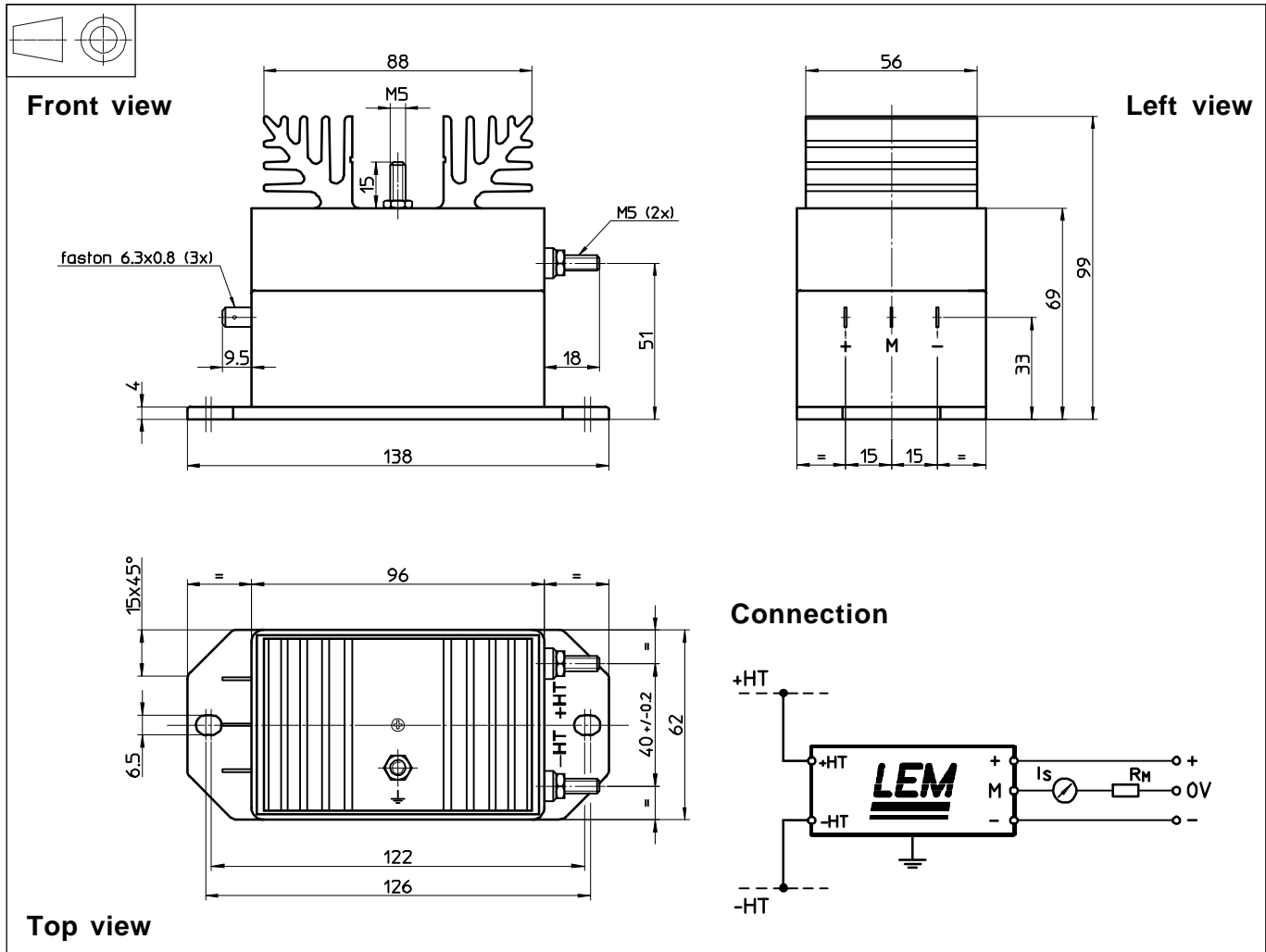

### Mechanical characteristics

- |                            |                                     |
|----------------------------|-------------------------------------|
| • General tolerance        | ± 0.3 mm                            |
| • Transducer fastening     | 2 holes Ø 6.5 mm<br>M6 steel screws |
| Fastening torque max.      | 5 Nm or 3.69 Lb - Ft.               |
| • Connection of primary    | M5 threaded studs                   |
| • Connection of secondary  | Faston 6.3 x 0.8 mm                 |
| • Connection to the ground | M5 threaded stud                    |
| • Fastening torque max.    | 2.2 Nm or 1.62 Lb. -Ft.             |

### Remarks

- $I_s$  is positive when  $V_p$  is applied on terminal +HT.
- The primary circuit of the transducer must be linked to the connections where the voltage has to be measured.
- This is a standard model. For different versions (supply voltages, turns ratios, unidirectional measurements...), please contact us.