

THIS DOCUMENT AND THE DATA DISCLOSED
HEREIN OR HERewith IS NOT TO BE REPRODUCED,
USED, OR DISCLOSED IN WHOLE OR IN PART
TO ANYONE WITHOUT PERMISSION OF VICOR CORP.

REV.	DESCRIPTION	DATE	APPROVED
#2	UPDATE TO SCREW POSITION	LDN 3/5/99	

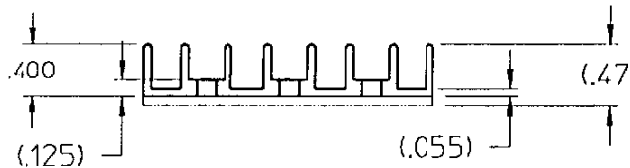
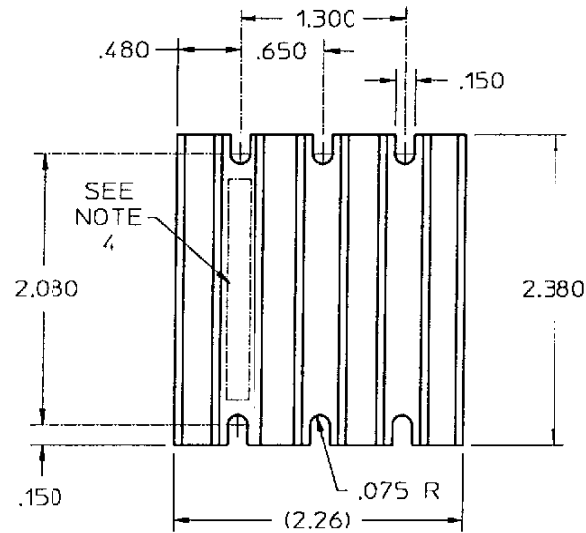

COPY

ORIGINAL
ONLY WHEN STAMPED
IN RED

NOTES

- 1.MATERIAL: MAKE FROM EXTRUSION 14612
- 2.FINISH: CLEAR CHROMATE WITH EXTENDED ("HEAVY") ETCH.
- 3.REMOVE ALL LOOSE BURRS.
- 4.MECHANICALLY STAMP PART NUMBER AND REVISION IN AREA SHOWN.

UNLESS OTHERWISE SPECIFIED
DIMENSIONS ARE IN INCHES
TOLERANCES ARE:

FRACTIONS	DECIMALS	ANGLES
= 1/64	.XX ± .01	± 1°0
	.XXX ± .005	

THIRD ANGLE PROJECTION

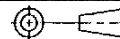

DO NOT SCALE DRAWING

APPROVALS	DATE
DRAWN:	5/91
CHECKED:	
ISSUED	
APP'D	

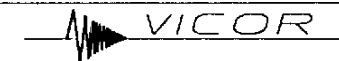

HEATSINK CROSSFLOW,
MINI MOD (.40 HG. SLOTTED)

SIZE	FSCM NO.	DWG. NO.	REV.
B	67131	05738	#2

SCALE FULL

SHEET 1 OF 1