

# AZ DISPLAYS, INC.

---

## SPECIFICATIONS FOR LIQUID CRYSTAL DISPLAY

PART NUMBER:

AGM1216A

DATE:

September 16, 2004



## 1.0 LCD Module Characteristics

No.	Item	Characteristics	Units
(1)	Module Size	37.2 (W) x 50.6 (H) x 3.1 (T)	mm
(2)	Format	128 x (R.G.B.) x 160	Dots
(3)	Active Area	32.05 (W) x 38.9 (H)	mm
(4)	Dot Size	0.065 (W) x 0.215 (H)	mm
(5)	Dot Pitch	0.075 (w) x 0.225 (H)	mm
(6)	Approximate Weight	TBD	g
(7)	LCD Type	CSTN (Negative/ Transmissive)	
(8)	Drive Method	Duty: 1/160 Bias: 1/11	
(9)	Viewing Direction	6 O'clock	
(10)	Back Light	White LED	
(11)	Drivers	S-44205A (Supports 4096, 65K colors)	

## 1.2 Mechanical Diagram

### 1.2.1 LCD Diagram

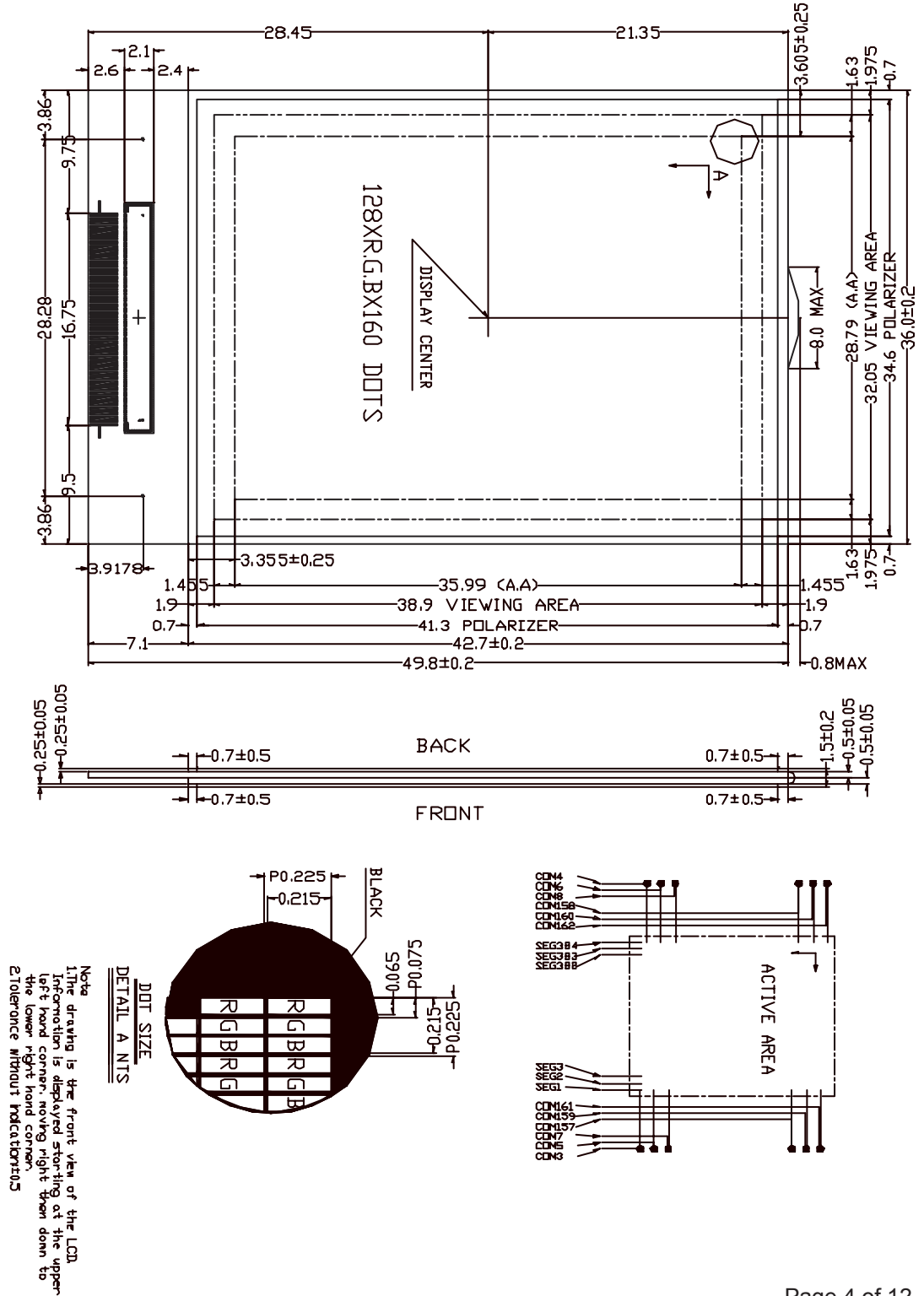

## 1.2.2 LCM Diagram

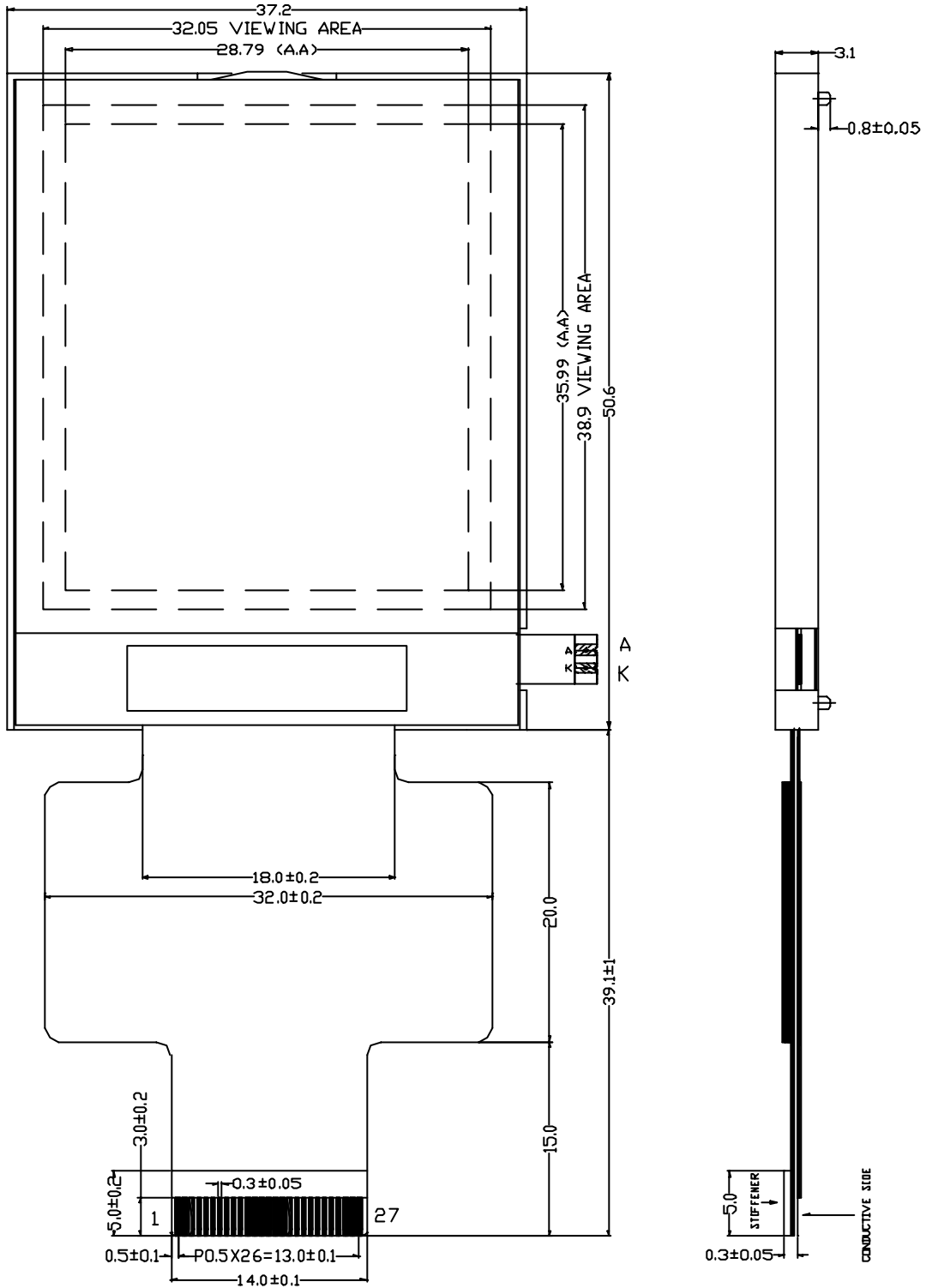

## 2.0 Absolute Maximum Rating

Gnd = 0V, Ta = 25 C

Item	Symbol	Min.	Max.	Unit
Power Supply Logic Voltage	V <sub>DD</sub>	-0.3	+4.0	V
Power Supply EEPROM	V <sub>CC</sub>	-0.3	+7.0	V
Power Supply Negative Voltage	V <sub>CL</sub>	-7.38		V
Contrast Voltage	V <sub>DD</sub> - V <sub>CL</sub>		+18.38	V

## 2.1 Environmental Absolute Maximum

Item	Storage		Operating		Remarks
	Min,	Max.	Min,	Max.	
Ambient Temperature	-30 C	80 C	-20 C	70 C	Note 1
Humidity	No Condensation				Note 2, 3

Note 1. Ta at -20 C -----< 48 hours, at 70 C ----< 120 hours.

Note 2. Temp at < 40 C, 85% RH MAX.

Note 3. Temp > 40 C, Absolute humidity must be less than 85% RH

## 3.0 Electrical Characteristics

Item	Symbol	Min.	Typ.	Max.	Unit
Supply Logic Voltage	V <sub>DD</sub>	2.4	3.0	3.3	V
EEPROM Voltage	V <sub>CC</sub>	2.7	3.0	5.5	V
"H" Input Voltage	V <sub>IH</sub>	0.8 V <sub>DD</sub>	-	V <sub>DD</sub>	V
"L" Input Voltage	V <sub>IL</sub>	0	-	0.2 V <sub>DD</sub>	V
"H" Output Voltage Note 4	V <sub>OH</sub>	V <sub>DD</sub> -0.4	-	-	V
"L" Output Voltage Note 5	V	-	-	0.4	V
Supply Current Note 6	I <sub>DD</sub>	-	-	2	mA

Note 4. I<sub>OH</sub> = -1 mA

Note 5. I<sub>OL</sub> = 1 mA

Note 6. V<sub>DD</sub> = 3.0 V

## 4.0 Optical Characteristics

Ta = 25 C

Item	Symbol	Condition	Min.	Typ.	Max.	Unit	Remark	
LCD Driving Voltage	V	-20 C	(15.2)	(16.2)	(17.2)	V	Note 1.	
		25 C	(14.6)	(15.6)	(16.6)			
		70 C	(13.8)	(14.8)	(15.8)			
Response Time	Rise	Tr	$\theta=\phi=0$	25 C	(150)	(230)		ms
	Fall	Tf	$\theta=\phi=0$	25 C	(150)	(230)		ms
Contrast ratio	CR	$\theta=\phi=0$	(18.0)	(30.0)				
Transmittance	T		(3.6)	(6.0)				
Chromaticity Coordinates	White	X	$\theta=\phi=0$	(0.25)	(0.30)	(0.35)	Note 2.	
		Y		(0.27)	(0.32)	(0.37)		
	Red	X	$\theta=\phi=0$	(0.47)	(0.52)	(0.57)		
		Y		(0.29)	(0.34)	(0.39)		
	Green	X	$\theta=\phi=0$	(0.29)	(0.34)	(0.39)		
		Y		(0.45)	(0.50)	(0.55)		
	Blue	X	$\theta=\phi=0$	(0.12)	(0.17)	(0.22)		
		Y		(0.12)	(0.17)	(0.22)		
Color Gamut (NTSC)	S			(26)		%		

Note 1. Duty driven using the LCD7000 (fFRM = 100 Hz, 1/160 duty, 1/11 bias)

Note 2. Duty driven using actual driver IC.

Note 3. All (figures) are estimates only.

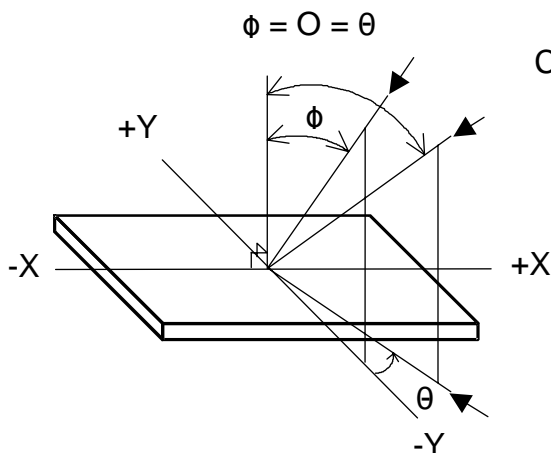

Definition of viewing angle.

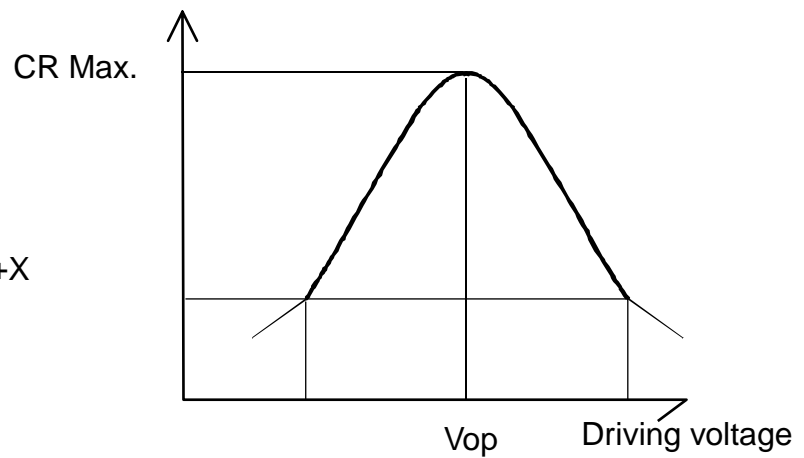

Definition of Contrast Ratio

## 5.0 Interface Pin Function

NO	SYMBOL	FUNCTION
1	DISP	TRST = H (Display off) Making /DISP low sets the D1 flag to 0 and the D0 flag to 0 (D1 = D0 = 0) in the driver output control register (08h) and turns OFF the display. To light the display after it has been turned OFF by this pin, make /DISP high and set the D1 flag to 1 and the D0 flag to 1 (D1 = 1, D0 = 1).
2	VSS	Ground pin, connected to 0 V
3	VCC	This pin is the power supply pin for EEPROM. connects to +2.7 V to +5.5 V
4	VDD	Power supply pin, connects to +2.4 V to +3.3 V
5	/CS1	The pin is chip select signal pin. When /CS1 = L, the chip is active, and data/commands can be input or output and I/O manipulated.
6	RS	This pin is usually connected to the least significant bit of a standard CPU address bus to identify whether data is an index register or data/command. RS = H: Indicates that D0 to D7 or D0 to D15 are data/command. RS = L: Indicates that D0 to D7 or D0 to D15 are an index register.
7	/WR	When i80 system parallel data transfer is selected (/WR), write is enabled by this signal. Data is written at the rising edge of this signal. When M68 system parallel data transfer is selected, this pin determines the data transfer direction, as follows: 0: Write 1: Read
8	/RD	When i80 system parallel data transfer is selected (/RD), read is enabled by this signal. When this pin is L, data is output to the data bus. When M68 system parallel data transfer is selected, this pin inputs an enable signal that triggers data write or read.
9	PSX	L: Serial H: Parallel
10	S80X	L: I80 system CPU mode H: M68 system CPU mode
11	BMOD	L: 16bit data bus H: 8bit data bus



NO	SYMBOL	FUNCTION
12	DB0	
13	DB1	
14	DB2	
15	DB3	
16	DB4	
17	DB5	
18	DB6(SCL)	<p>This is a bidirectional data bus connected to an 8-bit or 16-bit standard CPU bus. When the serial interface is selected (PSX = L), D7 functions as a serial data input pin (SI), and D6 serves as a serial clock input pin (SCL). At this time, D0 to D5 and D8 to D15 go into a high-impedance state. When the 8-bit data bus is selected, only D0 to D7 are used, and D8 to D15 go into a high-impedance state. Data is input starting from its higher byte, followed by the lower byte. If the chip is not selected, all D0 to D15 go into high-impedance state.</p>
19	DB7(SI)	
20	DB8	
21	DB9	
22	DB10	
23	DB11	
24	DB12	
25	DB13	
26	DB14	
27	DB15	

## 6.0 Block Diagram

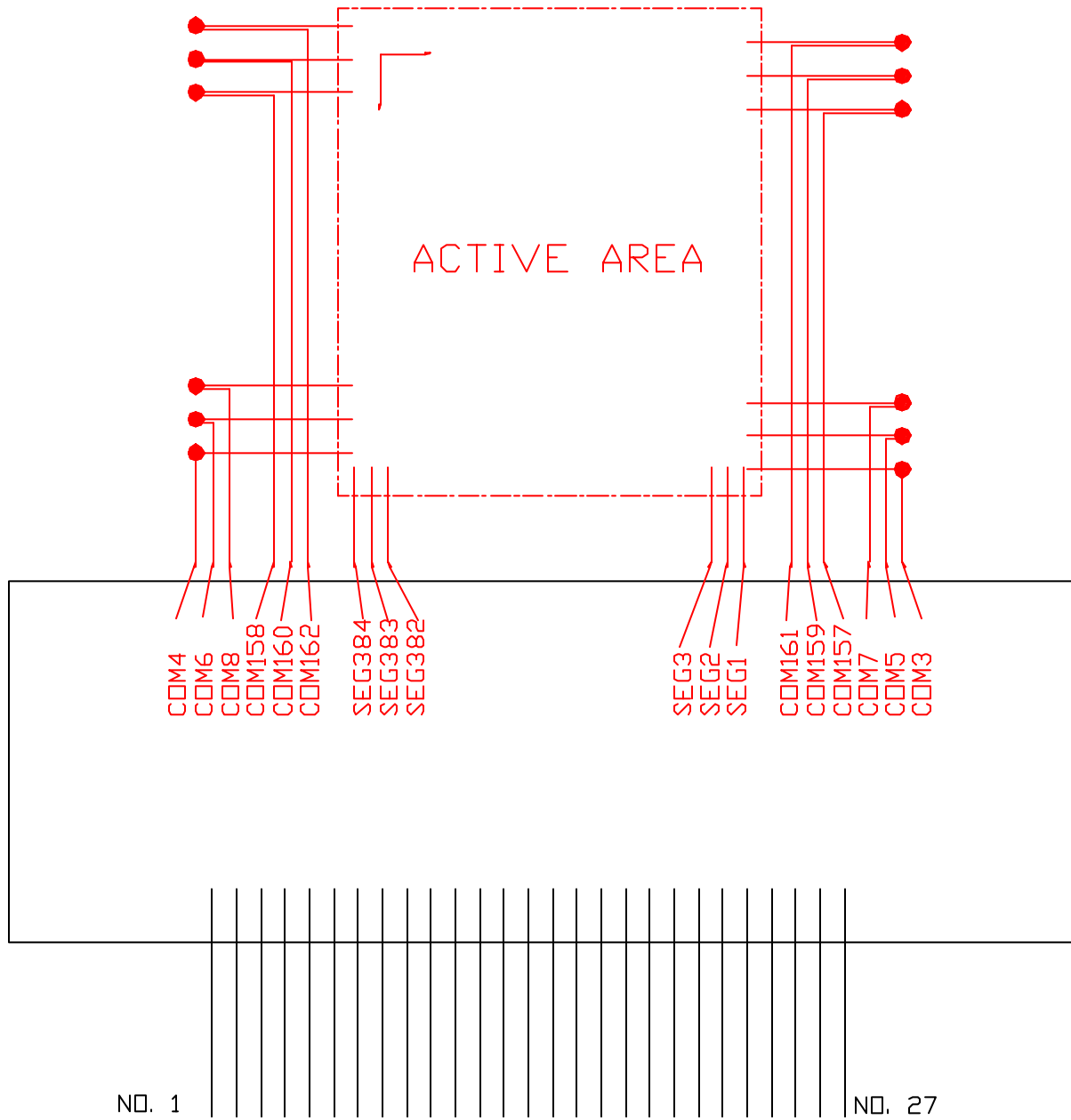

## 7.0 Power supply for LCD module

Figure 7-5. Power Supply Circuit Block Diagram

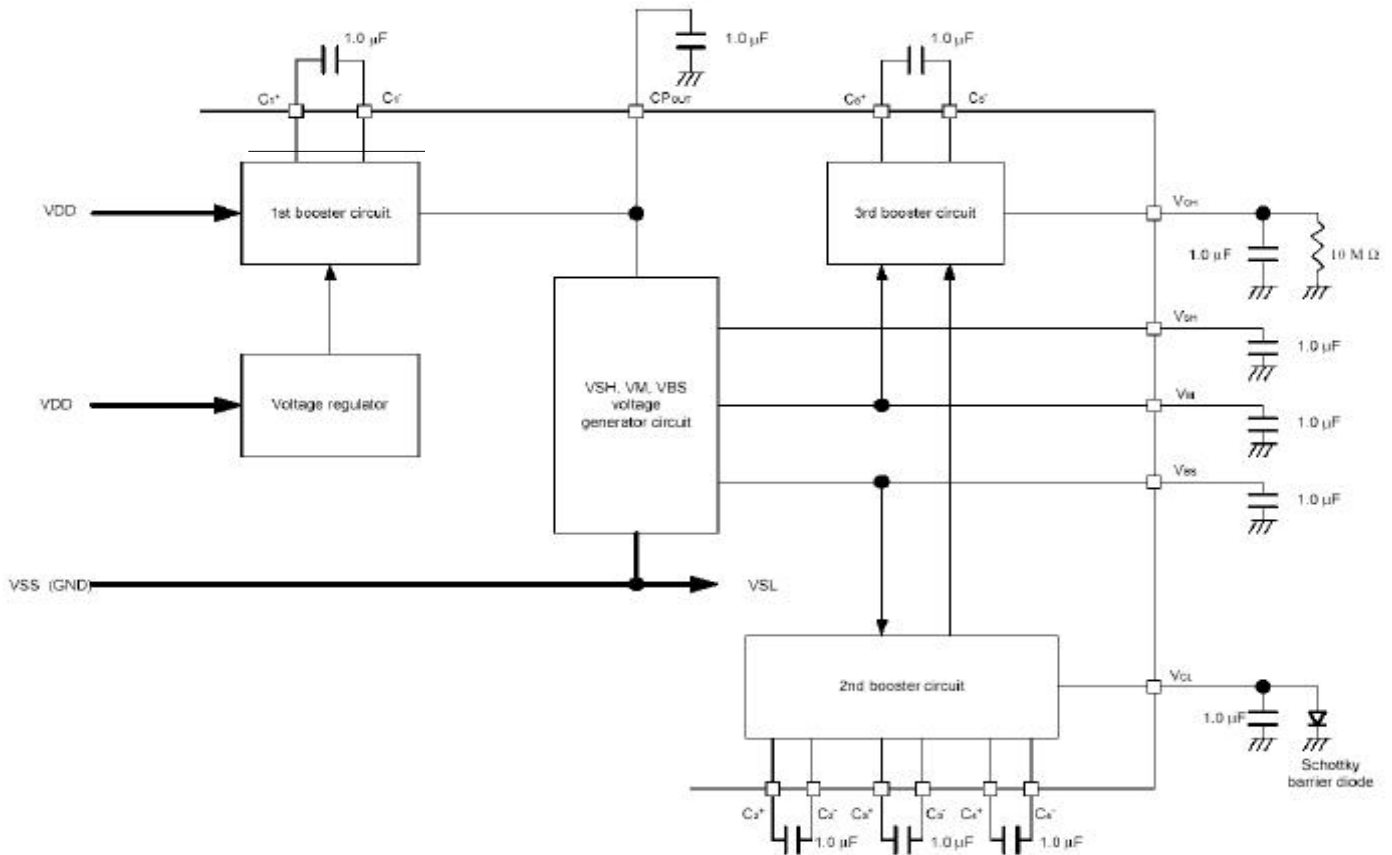

**Remark 1.** Connect a schottky barrier diode ( $V_F = 0.45 \text{ V Max. at } I_F = 10 \text{ mA, } V_R \geq 30 \text{ V}$ ) between GND and the  $V_{CL}$  pin.

**2.** Select capacitors (Character B) which have enough absolute maximum voltage ratings for the following operating voltage.

	<Main-Duty>	<Sub-Duty>		<Main-Duty>	<Sub-Duty>
$V_{BS}$ :	2.523	$V_{SH}$	$C_{2-}$ :	0 to -2.523	0 to -3.5
$V_{SH}$ :	$V_{SH}$	$V_{SH}$	$C_{2+}$ :	0 to 2.523	0 to 3.5
$V_M$ :	$V_{SH}/2$	$V_{SH}/2$	$C_{3-}$ :	-2.523 to -5.046	0 to -3.5
$CP_{OUT}$ :	3.55	3.55	$C_{3+}$ :	0 to 2.523	0 to 3.5
$V_{CL}$ :	-7.569	-7	$C_{4-}$ :	-5.046 to -7.569	-3.5 to -7.0
$V_{CH}$ :	$7.569 + V_{SH}$	$7.0 + V_{SH}$	$C_{4+}$ :	0 to 2.523	0 to 3.5
$C_{1-}$ :	0 to 2.2	0 to 2.2	$C_{5-}$ :	1.764 to -7.569	1.75 to -7.0
$C_{1+}$ :	2.2 to 3.55	2.2 to 3.55	$C_{5+}$ :	$7.569 + V_{SH}$ to 1.764	1.75 to $7.0 + V_{SH}$

## 8.0 Backlight Characteristics

The LED chips are distributed over the entire lighted area to provide the most uniform lighting.

### 1. Electrical Ratings:

Item	Symbol	Condition	Min.	Typ.	Max.	Unit
Forward Voltage	Vf	If=15 mA	10	10.2		V
Reverse Voltage	Vr		-	-	5.0	V
Luminance	Lv	If=15 mA	1600	1800	-	cd/m <sup>2</sup>
LED color	White					

### 2. Internal Circuit Diagram

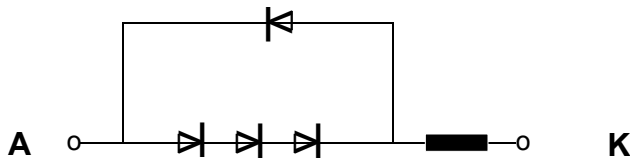

For operation above 25 C, the electrical ratings must be derated. The value of the current derating is -0.36 mA / degree C for DC drive and -0.86 mA / degree C for Pulse drive. Power dissipation is 0.75 mW / degree C.

### 3. Measurement Method

The luminance is the average value of 5 points. The ratio of Lv min. / Lv max. is greater than 0.8 cd/m. The minimum ratio is 0.8. The measurement instrument is a BM-7 Luminance Colormeter with an aperture of 01 degree.

