

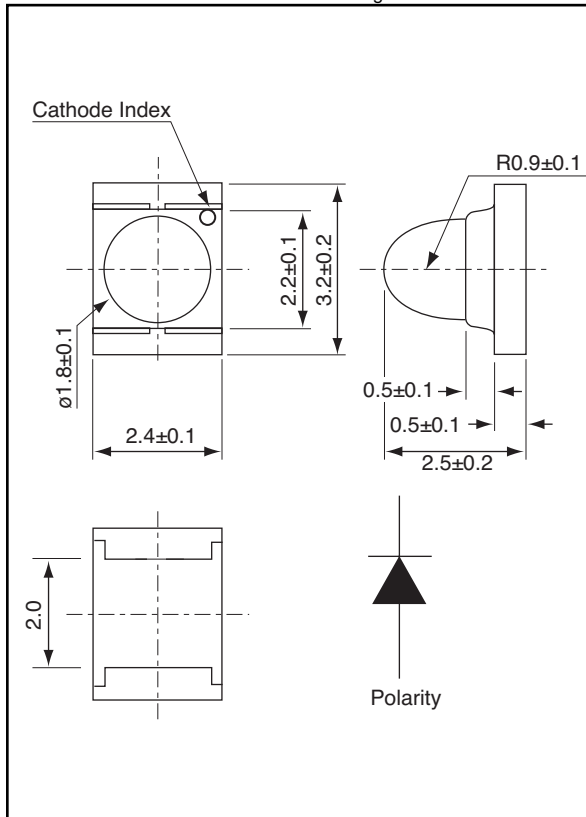

Weight: 2.0 Unit: mm



Product specifications contained herein may be changed without prior notice. It is therefore advisable to contact Purdy Electronics before proceeding with the design of equipment incorporating this product.

# AND5GA

## GaP Ultra Bright Green Light Emission Surface Mount Package

### Features

- Small package size with dome lens
- RoHS Compliant
- 3.2 (l) x 2.4 (w) x 2.6 (h) size
- Suitable for REFLOW soldering
- Recommended Forward Current: 10 mA

### Maximum Ratings (T<sub>a</sub> = 25°C)

Characteristics	Symbol	Rating	Unit
Forward Current	I <sub>F</sub>	25	mA
Reverse Voltage	V <sub>R</sub>	5	V
Power Dissipation	P <sub>D</sub>	60	mW
Operating Temperature Range	T <sub>Op</sub>	-40 to 85	°C
Storage Temperature Range	T <sub>Stg</sub>	-40 to 90	°C

### Electro-Optical Characteristics (T<sub>a</sub> = 25°C)

Characteristics	Symbol	Test Condition	Minimum	Typical	Maximum	Unit
Forward Voltage	V <sub>F</sub>	I <sub>F</sub> = 20 mA	-	2.1	2.4	V
Reverse Current	I <sub>R</sub>	V <sub>R</sub> = 5 V	-	-	10	μA
Luminous Intensity	I <sub>V</sub>	I <sub>F</sub> = 20 mA	75	125	-	mcd
Peak Emission Wavelength	I <sub>P</sub>	I <sub>F</sub> = 20 mA	-	570	-	nm
Spectral Line Half Width	Δλ	I <sub>F</sub> = 20 mA	-	30	-	nm
Dominant Wavelength	λ <sub>d</sub>	I <sub>F</sub> = 20 mA	-	571	-	nm
Full Viewing Angle	θ	I <sub>V</sub> = 1/2 Peak	-	30	-	degree

### Precaution

Please be careful of the following:

1. Manual soldering: maximum temperature of iron tip: 260°C max.  
Soldering time: within 5 sec. per solder-land  
Soldering portion of lead: up to 1.6 mm from the body of the device
2. Reflow solder: recommended condition is as follows:

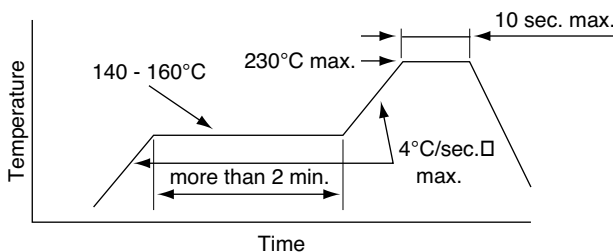

The following soldering patterns are recommended for reflow soldering

