

Industrial

24mm Diameter

1/2 Watt, Composition

Rotary Potentiometer

Features

- Versatile Mounting Styles
 - Bushing
 - Twist or Bend Tab
 - Snap-in PC Bracket
 - PC Terminal
- Single, Tandem, or Concentric Units
- Power Switch Available
- Panel Seal Available
- Wide Resistance Range
- Low Noise
- RoHS compliant

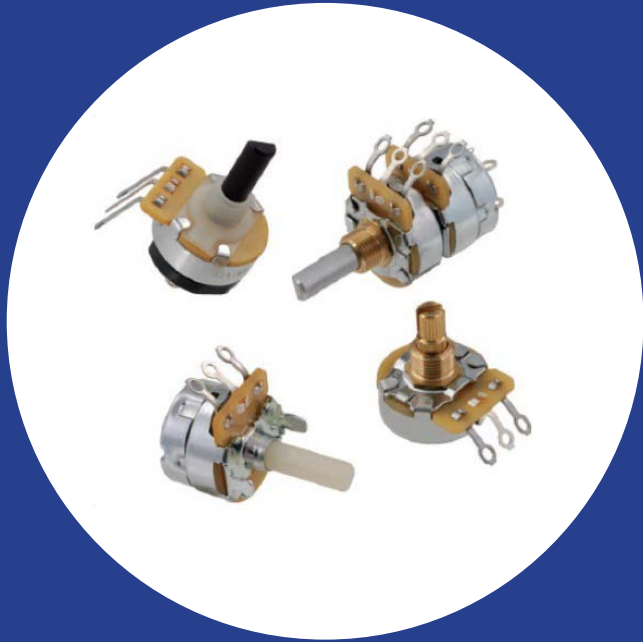

Electrical and Mechanical Specifications

Resistance Range

100 ohms through 10 Megohms, linear
1K ohms through 1 Megohms, audio

Resistance Tolerance

±30%, ±20%, ±10%

Power Rating

1/2 watts @ 55°C (Resistance up to 100K ohms)
1/3 watts @ 55°C (Resistance above 100K ohms)

Dielectric Strength

1080 VAC for 1 minute

Maximum Operating Voltage

750 VDC

Insulation Resistance

100 Megohms minimum @ 250 VDC

Angle of Rotation

Total Rotation (Potentiometer and Switch)
With rotary switch: 320°
Without switch or with push switch: 300°
Electrical Effective Angle (Potentiometer)
300°

Rotational Torque

Standard: 54 - 432 gf-cm
(Consult CTS for special torque)

Stop Strength

10.36 kgf-cm minimum

Push-Pull Strength of Shaft

10 kg for 10 seconds

Rotational Life

Standard: 10K cycles
Special: 100K, 250K cycles

Operating Temperature

-10°C to +80°C

Solder Heat Resistance

260°C for 5 seconds

Mounting Information

- Bushing
- Twist Tab
- Bend Tab
- Snap-in PC Bracket
- PC Terminal

OPTIONAL POWER SWITCHES

Series	Contact Arrangement	Electrical Rating	Outline Drawing
FR-GC	SPST Rotary	3 amps @ 125 volts, 1 amp @ 250 volts AC	
GC	SPST Rotary	5 amps @ 20 volts DC	
Actuating Angle – 20° Actuating Torque – 7 to 17 in. oz. (504 to 1224 gf-cm)			
DIMENSION: $\frac{\text{mm}}{\text{inch}}$			

TGC	SPST Rotary	6 amps @ 125 volts AC	
Actuating Angle – 20° Actuating Torque – 7 to 17 in. oz. (504 to 1224 gf-cm)			
DIMENSION: $\frac{\text{mm}}{\text{inch}}$			

TV-023	SPST Rotary	TV-5 rating	
Actuating Angle – 20° Actuating Torque – 10 to 20 in. oz. (720 to 1440 gf-cm)			
DIMENSION: $\frac{\text{mm}}{\text{inch}}$			

OPTIONAL POWER SWITCHES

Series	Contact Arrangement	Electrical Rating	Outline Drawing
040	SPST Push-on Push-off	6 amps @ 125 volts AC	
Pre-travel 13/64" (5.2 mm) Activating Force: 2 to 5 lb (0.9 to 2.3 kgf)			SWITCH TERMINAL HOLES-1.93/.076x3.15/.124
DIMENSION: $\frac{\text{mm}}{\text{inch}}$			
041	SPDT Push-on Push-off	6 amps @ 125 volts AC	
Pre-travel 13/64" (5.2mm) Activating Force: 2 to 5 lb (0.9 to 2.3 kgf)			SWITCH TERMINAL HOLES-1.93/.076x3.15/.124
DIMENSION: $\frac{\text{mm}}{\text{inch}}$			
050	SPST Rotary	3 amps @ 125 volts AC (Shallow construction switch) 7.5 amps @ 20 volts DC	
Actuating Angle: 25° Actuating Torque: 2 to 15 in. oz. (144 to 1080 gf-cm)			SWITCH TERMINAL HOLES-1.93/.076x3.15/.124
DIMENSION: $\frac{\text{mm}}{\text{inch}}$			
FR-027	DPST Rotary	3 amps @ 125 volts, 1 amp @ 250 volts AC	
Actuating Angle: 20° Actuating Torque: 10 to 20 in. oz. (720 to 1440 gf-cm)			SWITCH TERMINAL HOLES 2.39/.094 x 3.18/.125
DIMENSION: $\frac{\text{mm}}{\text{inch}}$			

OPTIONAL POWER SWITCHES

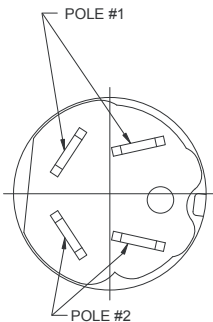
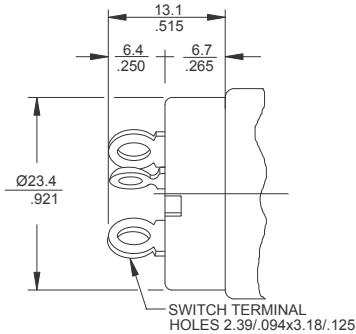
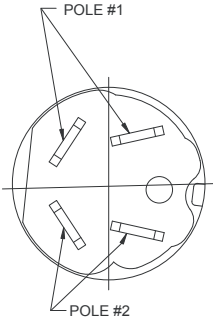
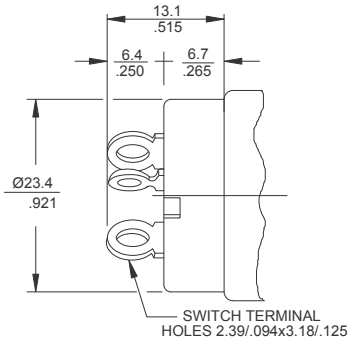
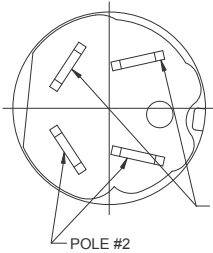
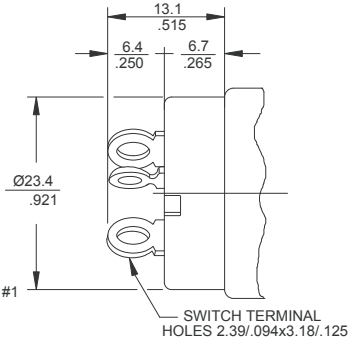
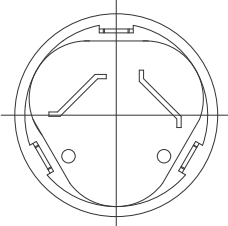
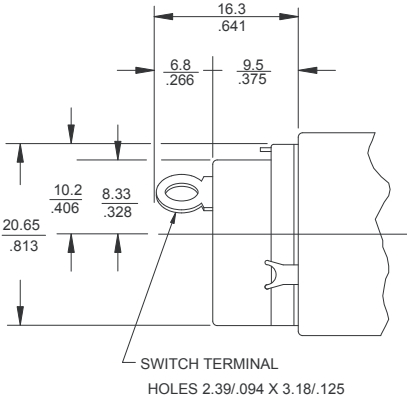
Series	Contact Arrangement	Electrical Rating	Outline Drawing	
<p>TV-020</p> <p>Actuating Angle: 20° Actuating Torque: 10 to 20 in. oz. (720 to 1440 gf-cm)</p> <p>DIMENSION: $\frac{\text{mm}}{\text{inch}}$</p>	<p>DPST Rotary</p>	<p>125 volts AC Pole #1, TV-1 rating Pole #2, TV-3 rating</p>		
<p>FR-028</p> <p>Actuating Angle: 20° Actuating Torque: 10 to 20 in. oz. (720 to 1440 gf-cm)</p> <p>DIMENSION: $\frac{\text{mm}}{\text{inch}}$</p>	<p>SPDT Rotary</p>	<p>3 amps @ 125 volts AC</p>		
<p>TV-021</p> <p>Actuating Angle: 20° Actuating Torque: 10 to 20 in. oz. (720 to 1440 gf-cm)</p> <p>DIMENSION: $\frac{\text{mm}}{\text{inch}}$</p>	<p>SPDT Rotary</p>	<p>TV-4 rating</p>		
<p>FR-K</p> <p>Pre-travel: 5/32" (3.97mm) Actuating force: 7 to 16 oz. - Single section control (198 to 454 gf) 7 to 20 oz. - Tandem control (198 to 567 gf)</p> <p>DIMENSION: $\frac{\text{mm}}{\text{inch}}$</p>	<p>SPST Pull-on Push-off</p>	<p>3 amps @ 125 volts AC</p>		

450T Metal Shaft, Bushing Mount, Type "T" Solder Lug Terminals

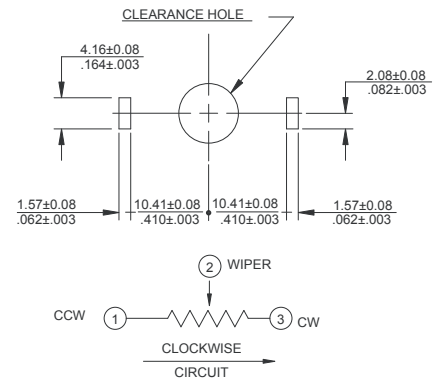
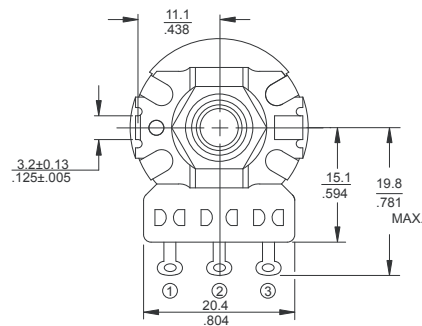
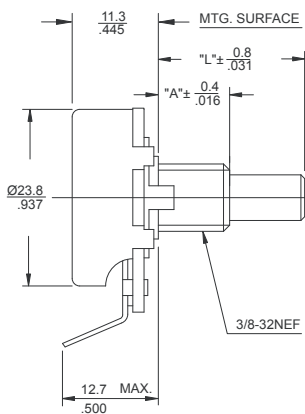

DIMENSION: $\frac{\text{mm}}{\text{inch}}$

450X / 450Y Metal Shaft, Bushing Mount, Printed Circuit Type "X" Or "Y" Terminals

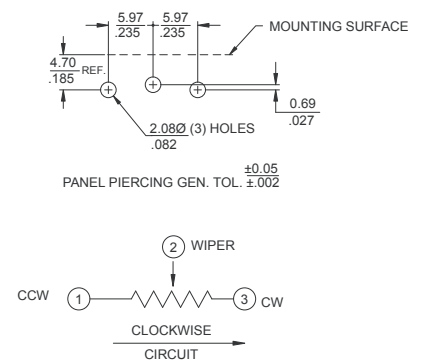
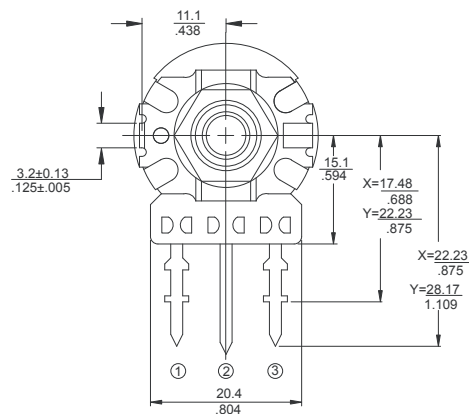
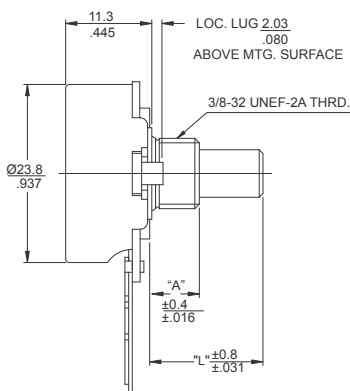

DIMENSION: $\frac{\text{mm}}{\text{inch}}$

450U Metal Shaft, Bushing Mount, Printed Circuit Type "U" Terminals

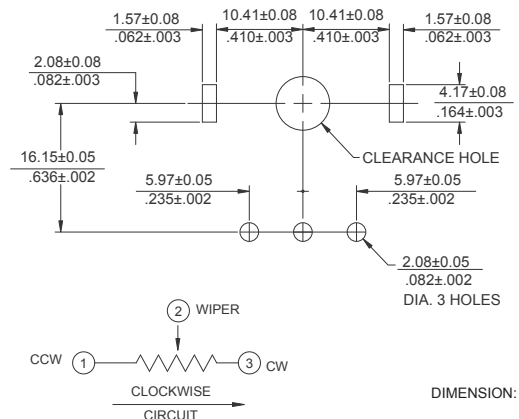
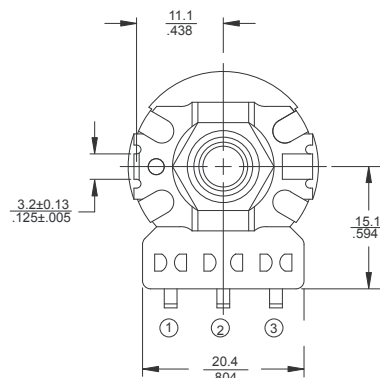
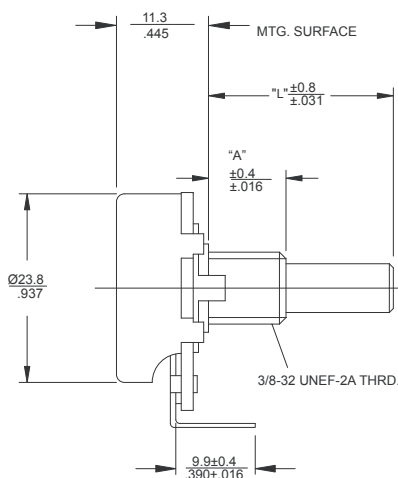

DIMENSION: $\frac{\text{mm}}{\text{inch}}$

450V Metal Shaft, Bushing Mount, Printed Circuit Type "V" Terminals

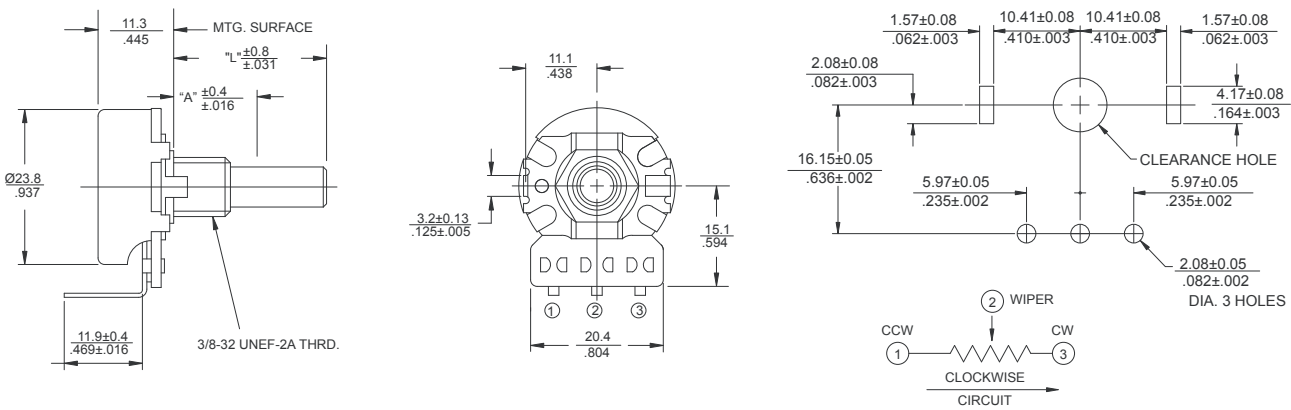

DIMENSION: $\frac{\text{mm}}{\text{inch}}$

UPE450RE Rear Extended Metal Shaft, Twist Tab Mount, Printed Circuit Type "U" Terminals

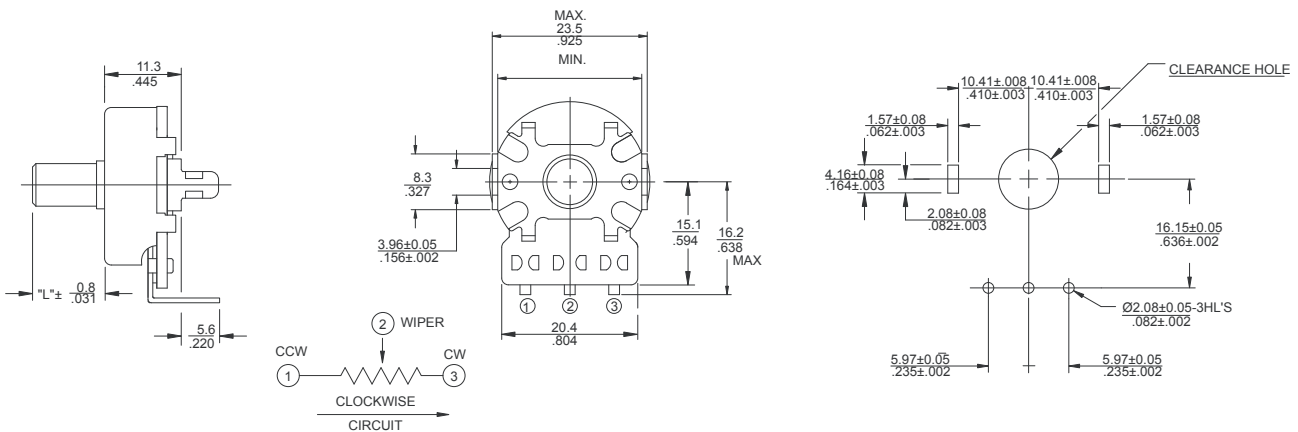

DIMENSION: $\frac{\text{mm}}{\text{inch}}$

T2-450 Dual-section, Metal Shaft, Bushing Mount, Type "T" Solder Lug Terminals

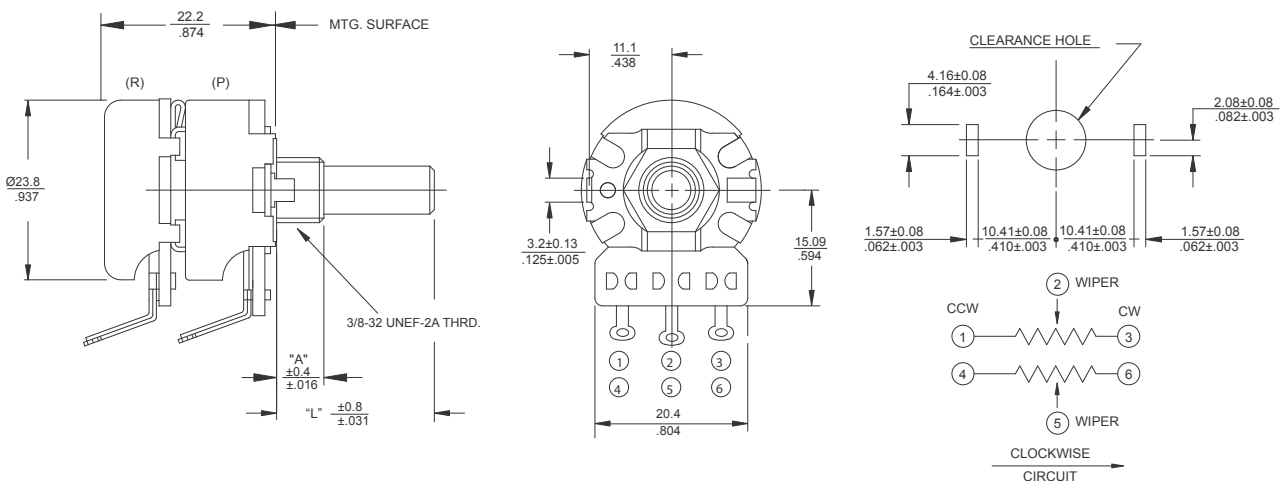

DIMENSION: $\frac{\text{mm}}{\text{inch}}$

* Consult CTS for its part no. or availability of more sections

TC2-450 Dual-section, Concentric Metal Shafts, Bushing Mount, Type "T" Solder Lug Terminals

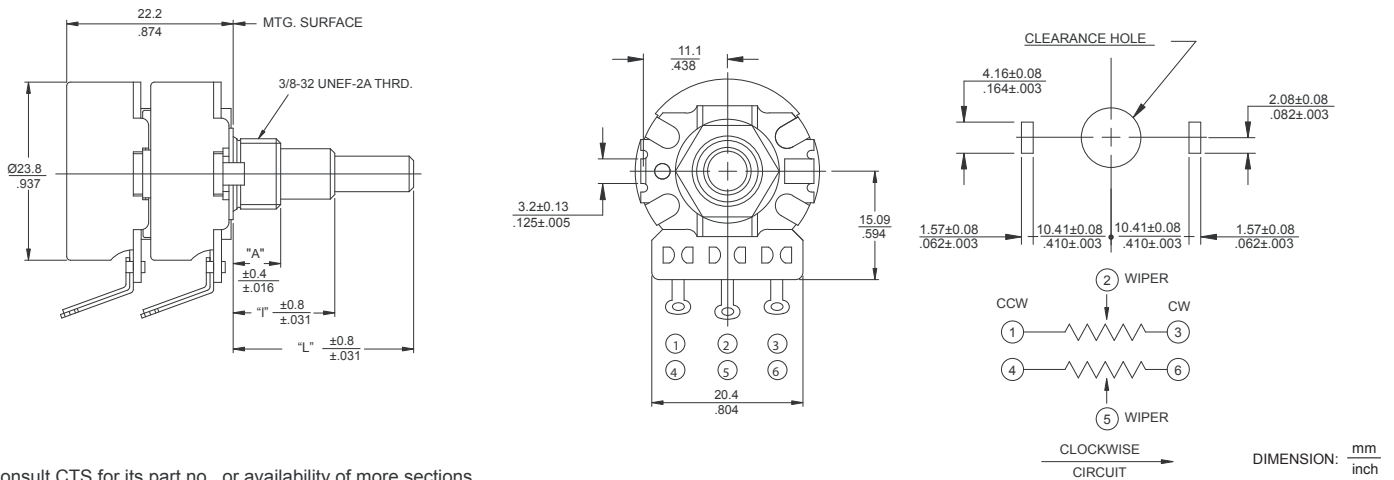

040-TMG450 Metal Shaft, Bushing Mount with Insulated Plate, Type "T" Solder Lug Terminals, 040 Switch

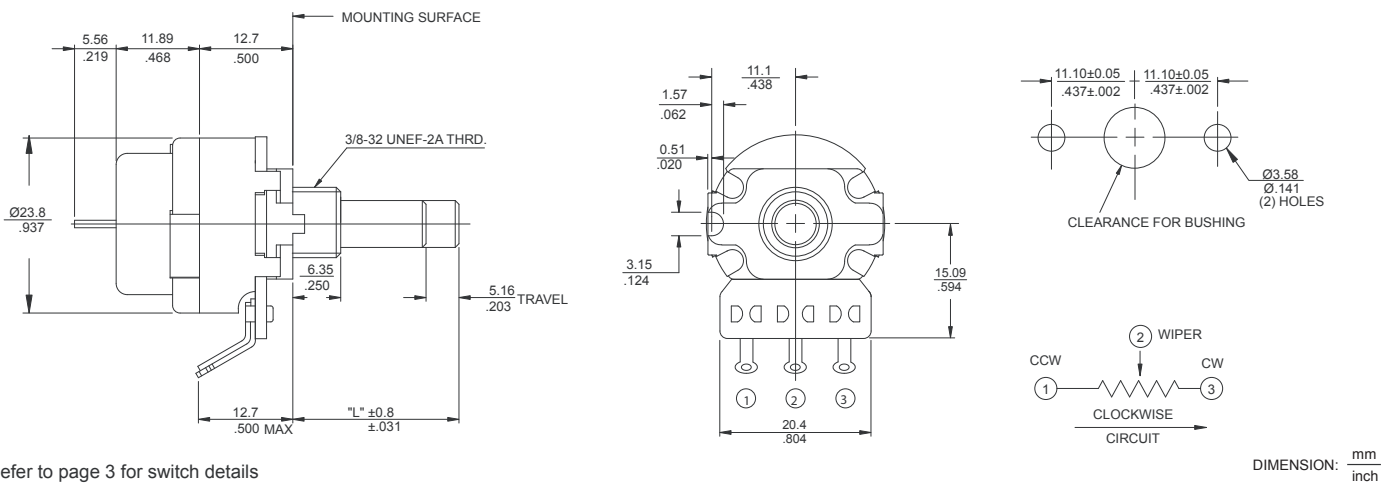

041-TMG450 Metal Shaft, Bushing Mount with Insulated Plate, Type "T" Solder Lug Terminals, 041 Switch

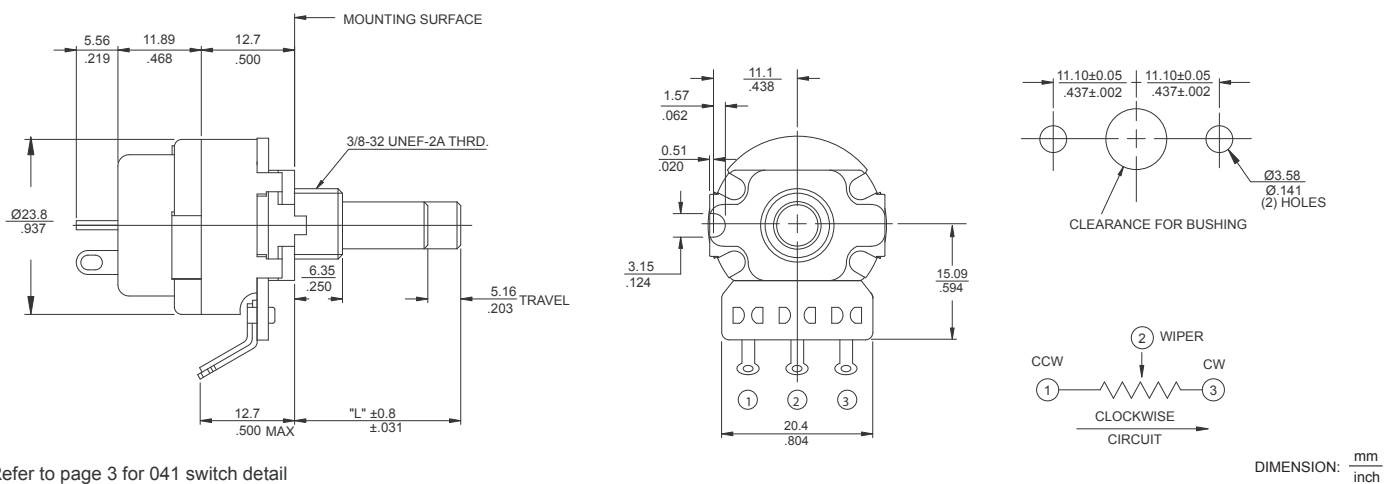

050-T450 Metal Shaft, Bushing Mount, Solder Lug terminals, 050 Switch

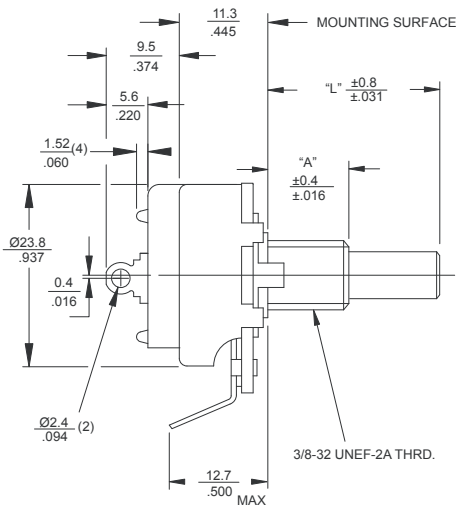

* Refer to Ordering Information for switch details

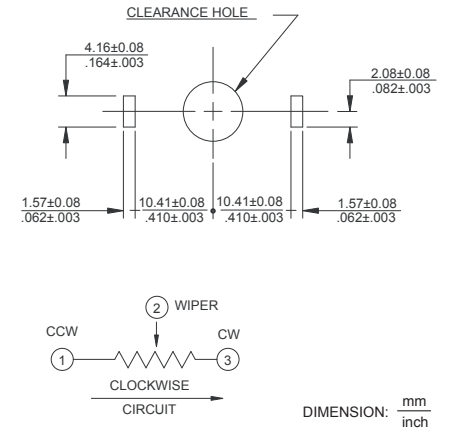
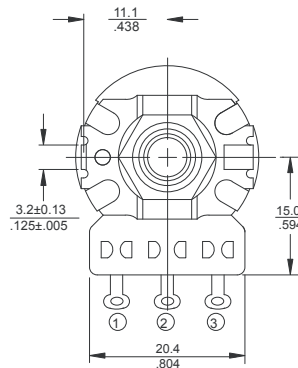

* Refer to page 3 for 050 switch detail

TGC-TMG450 Metal Shaft, Bushing Mount with Insulated Plate, Type "T" Solder Lug Terminals, TGC Switch

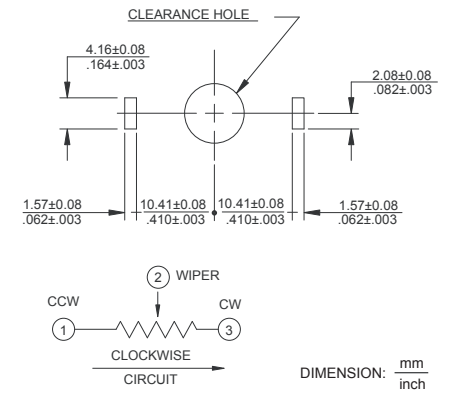
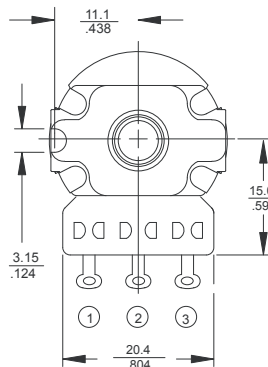
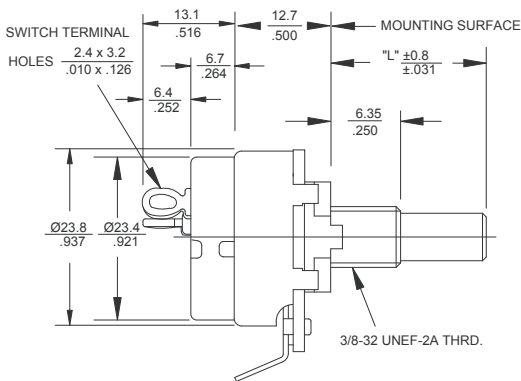

* Refer to page 2 for TGC switch detail

Shaft Trim Options

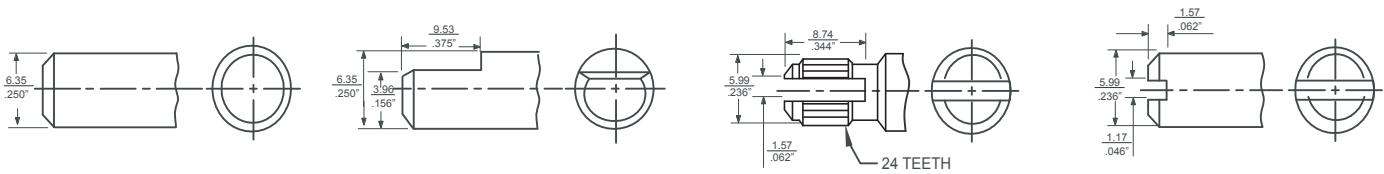

DIMENSION: mm / inch

Ordering Information

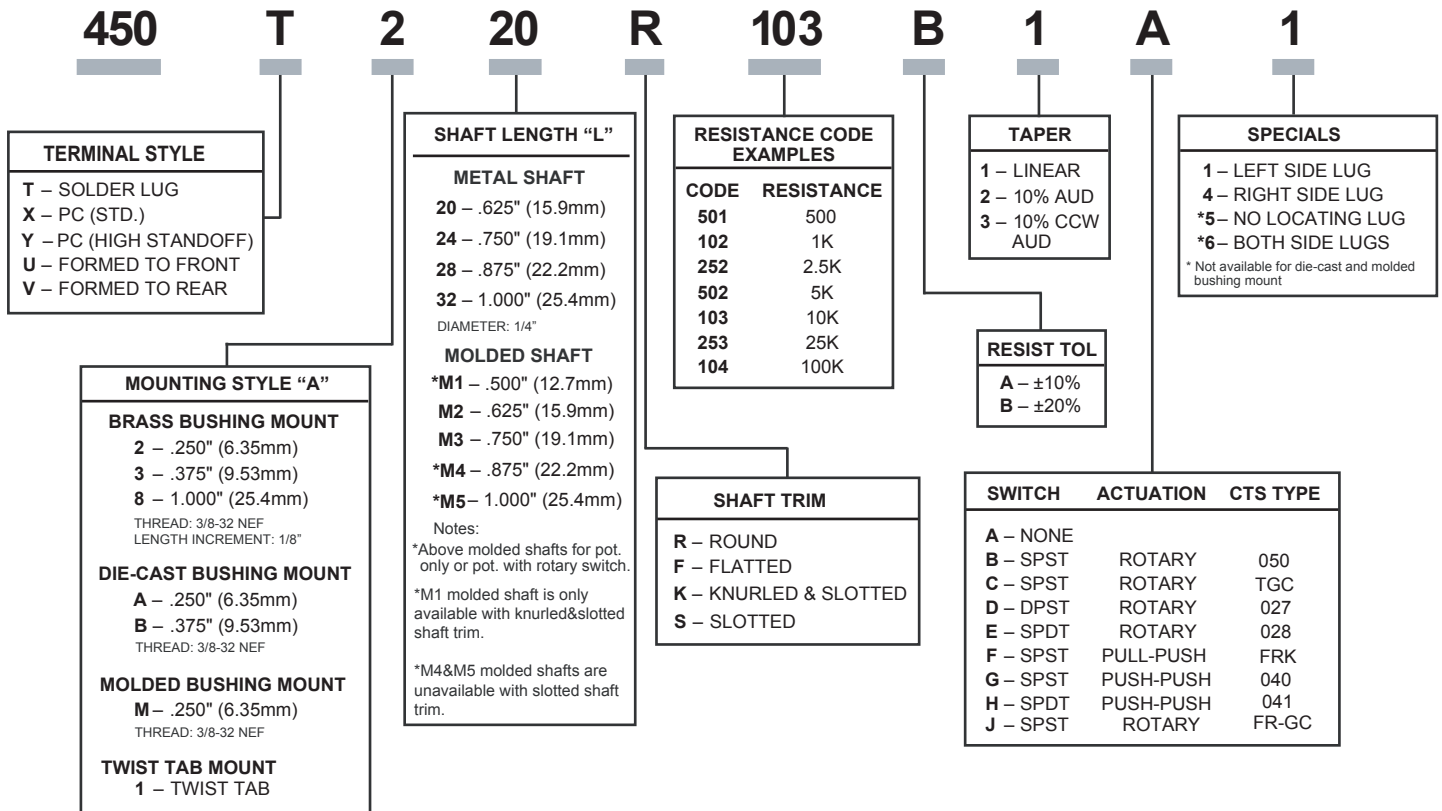

Please consult factory for other mounting options or common features not listed.