

Features

- Low voltage operation (VCC = 2.8V)
- Low saturation voltage.
- Low operating current.
- Constant current control by IM pin.
- DFN-6 & SC-70 Package

General Description

The AT5560 is a 1-channel low-saturation, low-voltage voice coil motor driver IC for Mobile Phone or portable application.

Applications

- Voice coil motor

Block Diagram

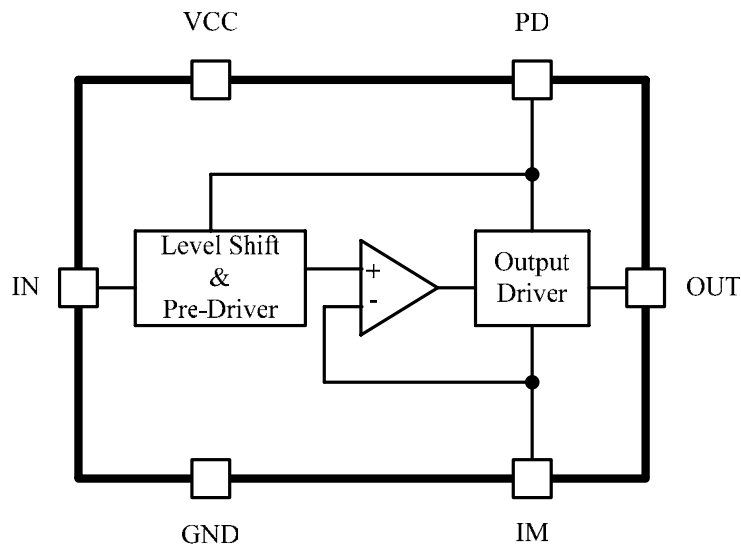

Pin Configuration

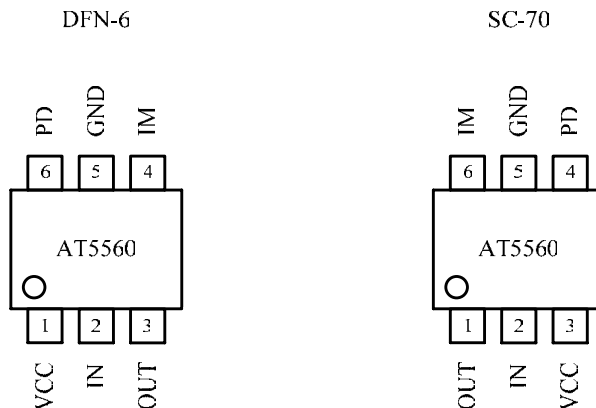

Aimtron reserves the right without notice to change this circuitry and specifications.

Pin Description

DFN-6

Pin NO.	Symbol	I/O	Description
1	VCC	P	Power supply
2	IN	I	Input pin to set the constant current.
3	OUT	O	Motor output pin
4	IM	I	Current detection terminal for constant current
5	GND	G	Ground
6	PD	I	Power down control pin

SC-70

Pin NO.	Symbol	I/O	Description
1	OUT	O	Motor output pin
2	IN	I	Input pin to set the constant current.
3	VCC	P	Power supply
4	PD	I	Power down control pin
5	GND	G	Ground
6	IM	I	Current detection terminal for constant current

Absolute Maximum Ratings

(Ta=25°C)

Item	Symbol	Ratings	Unit
Supply voltage VCC	VCC	6.0	V
Input voltage	V _{IN}	VCC+0.4	V
Maximum output current	I _{out}	200	mA
Power dissipation	P _d	300	mW
Operating temperature	T _{opr}	-40~125	°C
Junction temperature	T _j	~+150	°C
Storage temperature range	T _{stg}	-60 ~ +150	°C
ESD Susceptibility *2	HBM	4	KV
	MM	200	V

- Stresses beyond those listed under “Absolute Maximum Ratings” may cause permanent damage to the device. These are stress ratings only, and functional operation of the device at these or any other conditions beyond those indicated in the operational sections of the specifications is not implied. Exposure to absolute maximum rating conditions for extended periods may affect device reliability.
- Device are ESD sensitive. Handling precaution recommended. The Human Body model is a 100pF capacitor discharged through a 1.5KΩ resistor into each pin.

Recommended Operating Conditions

(Ta=25°C)

Item	Symbol	Ratings	Unit
Supply voltage VCC	VCC	+2.0 ~ +5.5	V
Control input voltage	V _{IN}	0 ~ VCC	V
H Bridge output current	I _{out}	100	mA
Logic input frequency	F _{in}	0 ~ 100	kHz

Electrical Characteristic

(Unless otherwise noted Ta=25 °C , VCC=2.8V)

Parameter	Symbol	Condition	Values			Unit
			Min.	Typ.	Max.	
Whole circuits						
Supply voltage	VCC		2.0	2.8	5.5	V
Circuit current during PD	ICCST	PD=L	--	0.1	5	μA
Circuit current	ICC	PD=H, IN=0V	--	0.3	0.5	mA
IN / PD pin						
H level input voltage	V _{INH}		VCC *0.8	--	VCC +0.4	V
L level input voltage	V _{INL}		-0.4	--	VCC *0.2	V
H level input current	I _{INH}	V _{PD} =3V	--	--	5	μA
L level input current	I _{INL}	V _{PD} =0V	-5	0	-	μA
Driver output						
Output constant current	I _{OUT}	RNF =1.5 Ω , PWM input control	10	--	120	mA
Output current during PD	I _{OUT,PD}	PD=L	--	--	5	μA
Saturation voltage	V _{SAT}	I _{OUT} =100mA	--	0.12	0.20	V

Typical Application Circuit

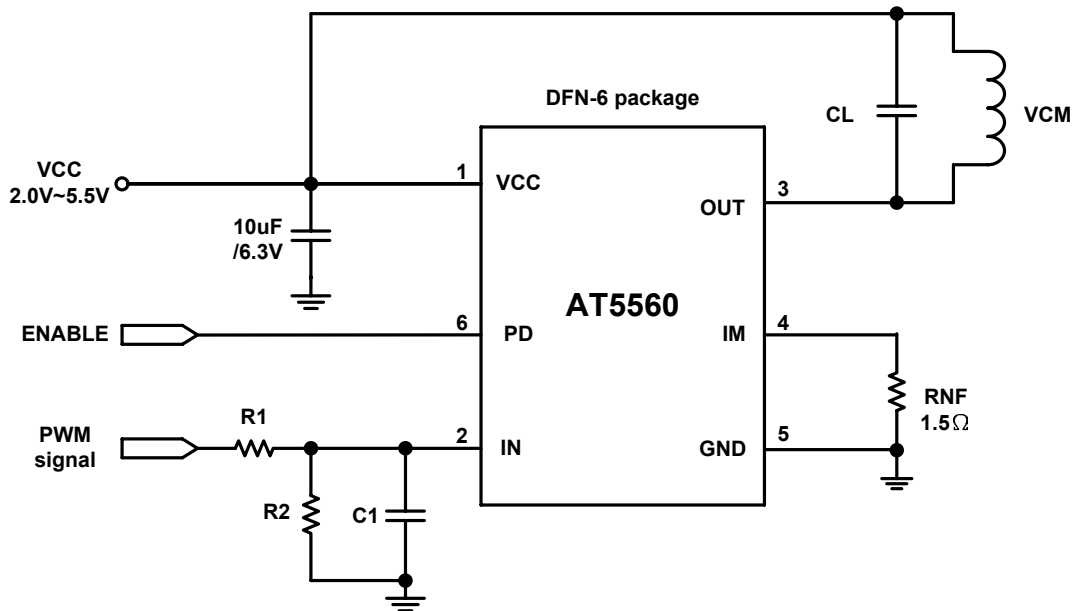

PWM signal

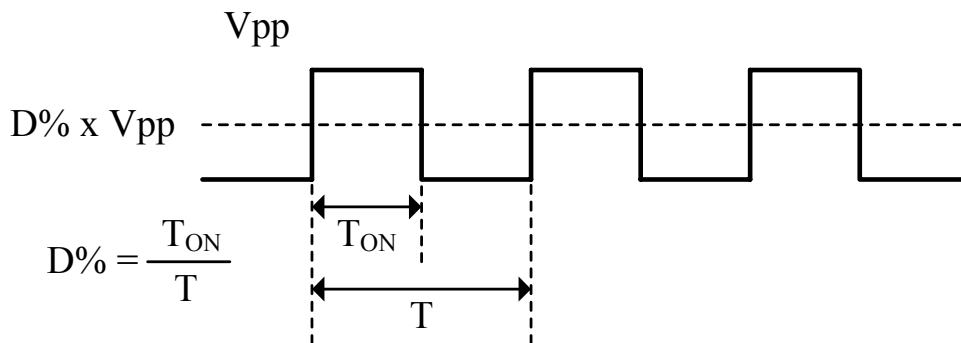
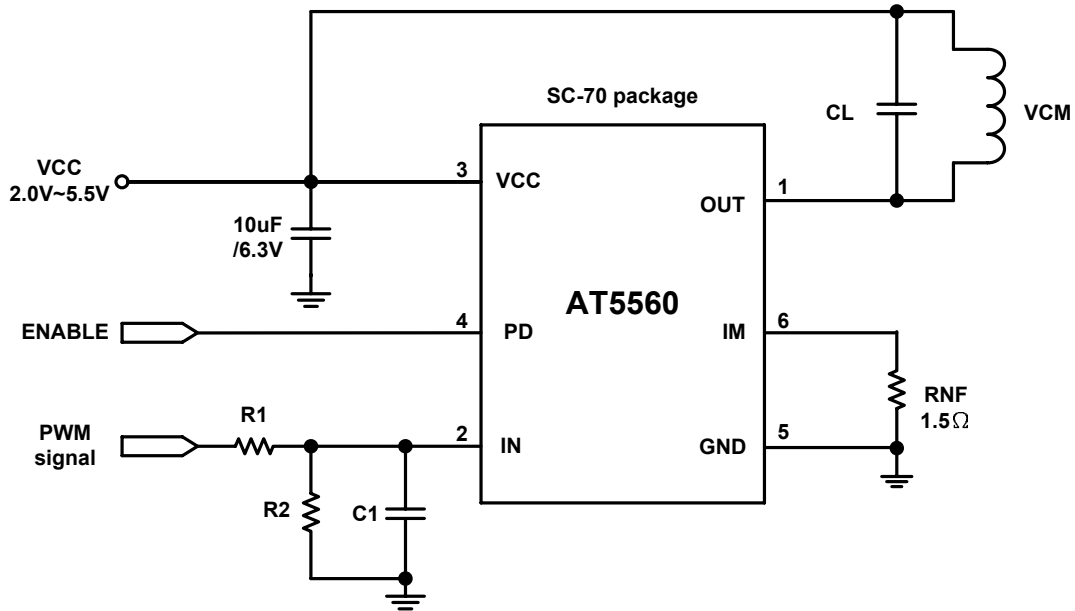

Fig 1 : Typical application circuit for AT5560 (DFN-6 package).

Typical Application Circuit



PWM signal

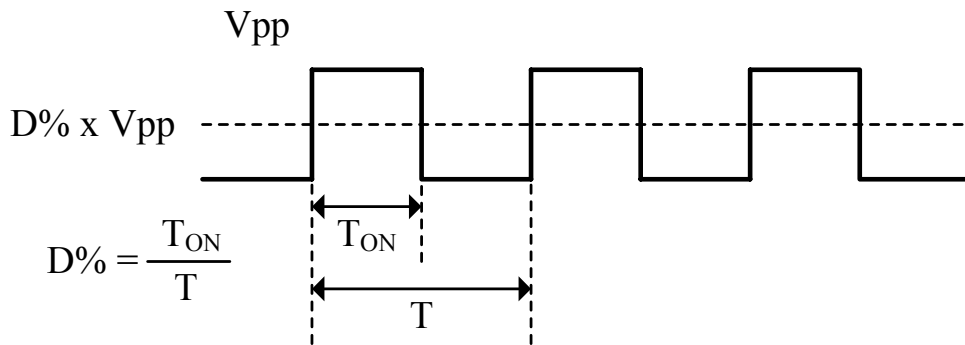

Fig 2 : Typical application circuit for AT5560 (SC70 package).

Application Information

- AT5560 provides constant current which can be evaluated by following equation.

$$I = \frac{V_{IN}}{10 \times RNF} \quad (1)$$

It's obviously that the accuracy value of constant current not only depends on the resistance, RNF, between IM pin and GND, but also the input voltage, V_{IN} . In order to get the suitable and stable input voltage level, V_{IN} , the PWM signal must be low-pass filtered by R1, R2, and C1. The input voltage should be calculated by following equation.

$$V_{IN} = \frac{R2}{R1 + R2} \times V_{PWM} = \frac{R2}{R1 + R2} \times D\% \times V_{PP}, \quad (2)$$

where D% means duty ratio of PWM signal, and V_{PP} is the amplitude of PWM signal. By setting different value of duty ratio of PWM signal, the corresponding voltage at IM pin we can get, then the constant current also be set simultaneously.

- As Fig 2 shows, in order to get the suitable and stable input voltage level, V_{IN} , the PWM signal must be low-pass filtered by R1, R2, and C1. The values of R1, R2, and C1 will determine -3dB frequency and DC value of V_{IN} . The -3dB frequency can be got by

$$\omega_{3dB} = \frac{1}{(R1//R2) \times C1} \quad (3)$$

For accuracy and stable value of constant current, the input voltage, V_{IN} , should be a DC value. So, it is suggested that the frequency of PWM signal must be larger than 100 times of -3dB frequency.

$$\omega_{3dB} = \frac{1}{100} \omega_{PWM} \quad (4)$$

- As above condition, to choose the R1, R2, and C1 is necessary for DC value of input voltage corresponding PWM signal. The following procedure will explain how to design the R1, R2, and C1.

For PWM signal frequency, $f_{PWM}=100\text{KHz}$, the sense resistance, $RNF=1.5\ \Omega$, the desired maximum output constant current is 70mA when duty ratio of PWM signal is 95%. The $V_{PP}=2.8\text{V}$, choosing R1, R2, and C1.

$$f_{3dB} = \frac{1}{2\pi \times (R1//R2) \times C1} = \frac{1}{100} \times f_{PWM} = 1\text{KHz}$$

If choosing $C1=0.1\mu\text{F}$, the $(R1//R2)=1.59\text{K}\ \Omega$.

And owing to equation (1) and (2), therefore,

$$\frac{R2}{R1 + R2} = \frac{V_{IN}}{D\% \times V_{PP}} = \frac{10 \times 0.07 \times 1.5}{95\% \times 2.8} \approx 0.394.$$

Thus, $R1=4.03\text{K}\ \Omega$, $R=2.63\ \text{K}\ \Omega$ can be get.

- The following diagrams show the characteristic curve for the voltage at IM pin vs. duty ratio of PWM signal and output current vs. duty ratio of PWM signal.

At this example, the PWM frequency is 20KHz, the sense resistance, $R_{NF}=1.5\Omega$, and the $R1=13K\Omega$, $R2=20K\Omega$, and $C1=0.1\mu F$ are set in front of IN pin respectively. Above settings can make AT5560 output 90mA when duty ratio of PWM signal is 80%.

From result, the correlation of output current and duty ratio of PWM signal is highly linear.

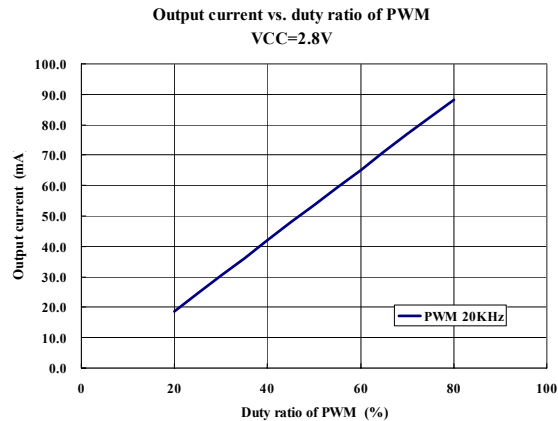
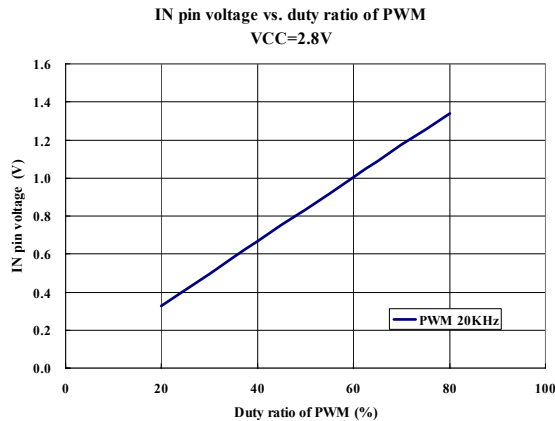

- The smaller value of sense resistance, R_{NF} , will cause lesser voltage variation at voltage IM pin. The accuracy of output current is closely dependent on voltage at IM pin. Another reason choosing smaller value of R_{NF} is that the decreasing voltage drop at IM pin can create the maximum output driving current when the PVCC is fixed. So $R_{NF}=1.5\Omega$ is the better choice.

Package Description : DFN-6

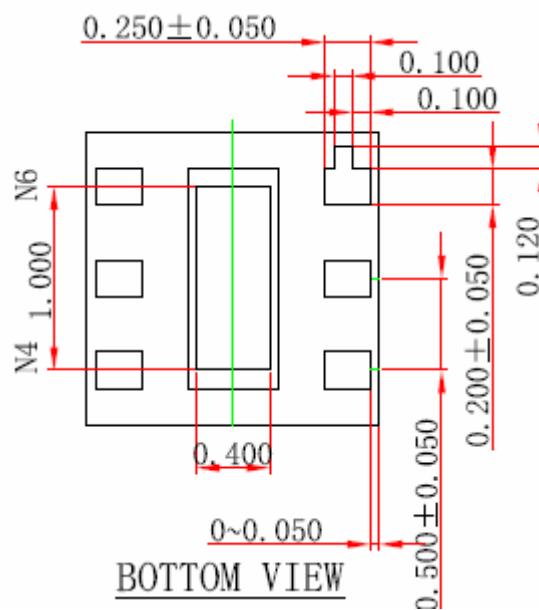
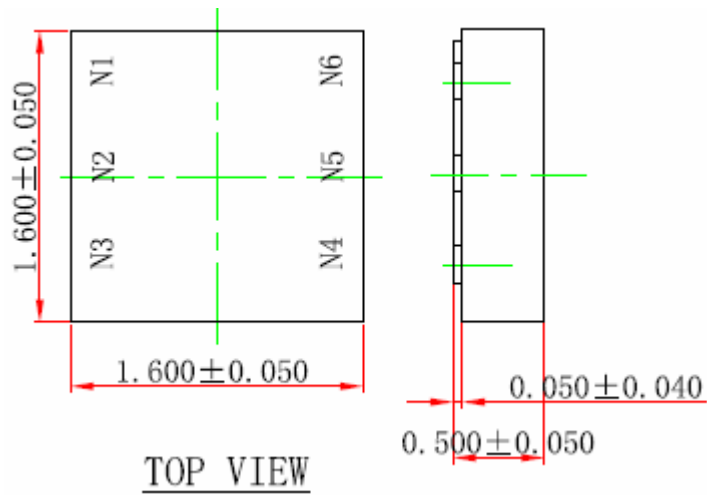

Package Description : SC-70

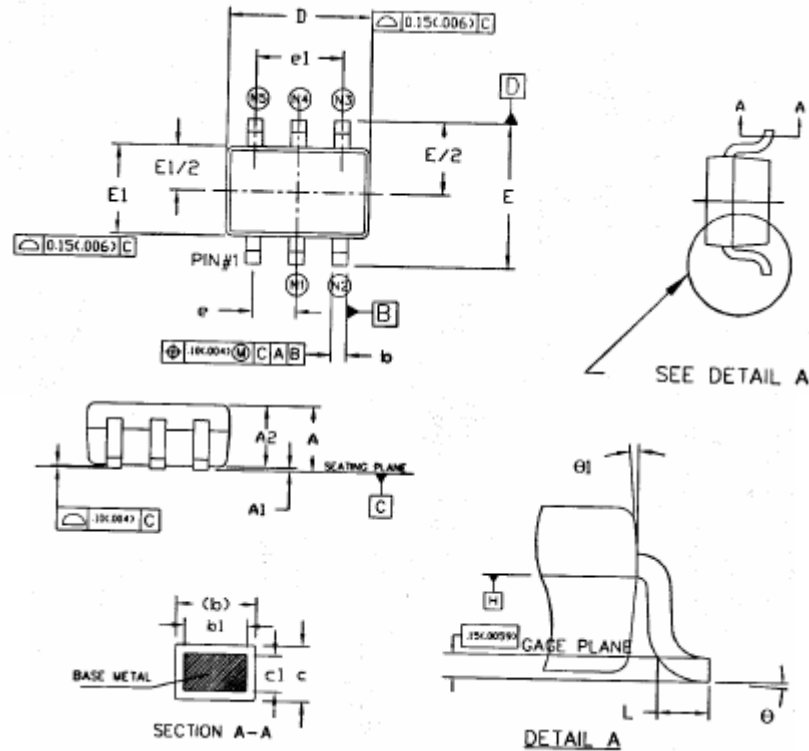

SYMBOL	INCHES		MILLIMETERS		NOTES
	MIN	MAX	MIN	MAX	
A	0.031	0.043	0.80	1.10	-
A1	0.000	0.004	0.00	0.10	-
A2	0.031	0.040	0.80	1.00	-
b	0.006	0.012	0.15	0.30	-
b1	0.006	0.010	0.15	0.25	-
c	0.003	0.010	0.08	0.25	-
c1	0.003	0.008	0.08	0.20	-
D	0.074	0.084	1.90	2.15	-
E	0.078	0.086	2.00	2.20	-
E1	0.045	0.055	1.15	1.35	-
e	0.0255 BSC.		0.65 BSC.		-
e1	0.0512 BSC.		1.30 BSC.		-
L	0.010	0.018	0.26	0.46	-
θ	0°	8°	0°	8°	-
θ1	4°	10°	4°	10°	-

Reflow Profiles

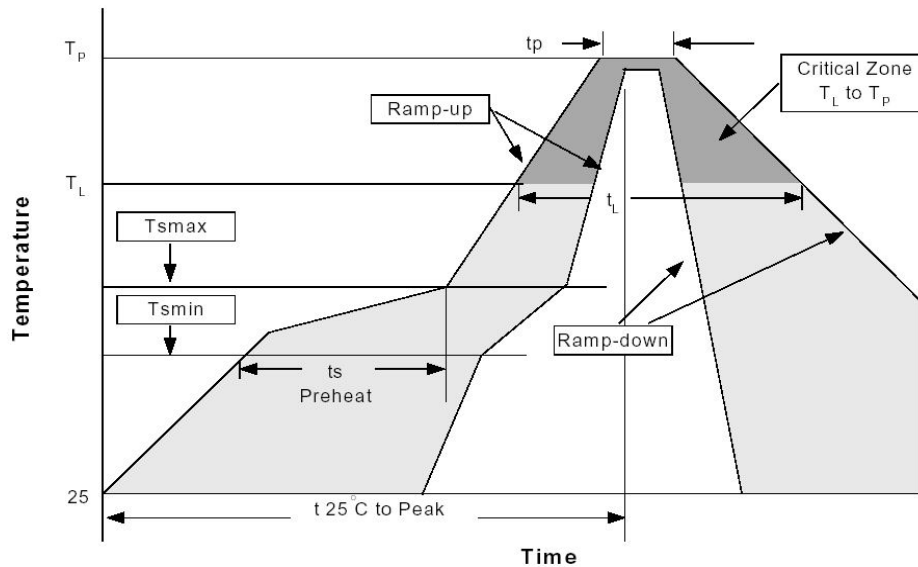

Profile Feature	Sn-Pb Eutectic Assembly		Pb-Free Assembly	
	Large Body Pkg. thickness ≥2.5mm or Pkg. volume ≥350mm ³	Small Body Pkg. thickness <2.5mm or Pkg. volume <350mm ³	Large Body Pkg. thickness ≥2.5mm or Pkg. volume ≥350mm ³	Small Body Pkg. thickness <2.5mm or Pkg. volume <350mm ³
Average ramp-up rate (T _L to T _P)	3°C/second max.		3°C/second max.	
Preheat -Temperature Min(T _{smin}) -Temperature Max (T _{smax}) -Time (min to max)(t _s)	100°C 150°C 60-120 seconds		150°C 200°C 60-180 seconds	
T _{smax} to T _L -Ramp-up Rate			3°C/second max.	
Time maintained above: -Temperature (T _L) -Time (t _L)	183°C 60-150 seconds		217°C 60-150 seconds	
Peak Temperature(T _P)	225+0/-5°C	240+0/-5°C	245+0/-5°C	250+0/-5°C
Time within 5°C of actual Peak Temperature (t _p)	10-30 seconds	10-30 seconds	10-30 seconds	20-40 seconds
Ramp-down Rate	6°C/second max.		6°C/second max.	
Time 25°C to Peak Temperature	6 minutes max.		8 minutes max.	

*All temperatures refer to topside of the package, measured on the package body surface.