

PLANAR POWER TRANSFORMER

P6142

Features

- * Planar windings
- * 4mm height above PCB
- * Low leakage inductance
- * High frequency operation
- * Externally configurable
- * 10–32V input capability
- * Auxiliary winding
- * Lead-free (Pb-free)

Applications

- * DC-DC converters
- * Flyback converters
- * 24V or 12V systems
- * 15V @ 1A output
- * 5V @ 3A output

DESCRIPTION

P6142 is a planar power transformer using multilayer PCB technology. It is intended for low profile high frequency discontinuous flyback DC-DC converters up to 500kHz. With careful design, output power exceeding 20W is achievable.

P6142 has split primaries that can be configured in series or parallel for nominal 24V and 12V systems respectively, with nominal 15V output. The recommended input voltage range is 10V to 32V. Additionally, an auxiliary winding is provided on the primary side.

The contacts to the host circuit board are made by solder connection to large plated-through holes in the P6142 PCB, thus ensuring low resistance connection. The ferrite is intended to sit within a PCB cut-out, giving a height above board of 4mm.

P6142 is lead-free (Pb-free) and suitable for conventional and lead-free processing.

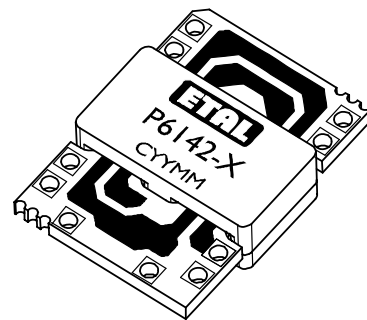

SPECIFICATIONS

Electrical

Typical values at T = 25°C, unless otherwise stated.

| Parameter | Conditions | Min | Typ | Max | Units |
|-------------------------------------|--|------------|------|------|-------|
| Primary Inductance | 100kHz, 100mV Each primary winding 3-8, 4-7 | | | | |
| | P6142-1 | 0.9 | 1.0 | 1.1 | μH |
| | P6142-2 | 1.11 | 1.26 | 1.41 | μH |
| Leakage Inductance | 500kHz, 100mV (3, 4)-(7, 8); link 1, 2, 9, 10; link 5, 6 | - | - | 100 | nH |
| Primary/Secondary voltage isolation | (3+4+5):2 | 500 | - | - | Vrms |
| Interwinding capacitance | 100kHz, 1V | - | 325 | - | pF |
| Total transformer losses | Vout = 5V at Iout = 3A 400kHz | - | 0.6 | - | W |
| DCR | Primaries 3-8, 4-7 | 5 | 7 | 9 | mΩ |
| | Auxiliary | 53 | 70 | 87 | mΩ |
| | Secondary: each section 2-1, 1-10, 10-9 | 3.4 | 4.5 | 5.6 | mΩ |
| Turns Ratio | (3-8):(4-7) | - | 1.0 | - | - |
| | (3-8):(5-6) | - | 0.67 | - | - |
| | (3-8):(9-2) | - | 0.67 | - | - |
| | (9-10):(10-1) | - | 1.0 | - | - |
| | (9-10):(1-2) | - | 1.0 | - | - |
| Operating range: | Ambient temperature | | | | |
| | | Functional | -40 | - | +85 |
| Storage | | -40 | - | +85 | °C |

Typical Magnetic Core Coefficients

| | | |
|----------------|------------------------|--------------------------------|
| C ₁ | Core factor | 0.514mm ⁻¹ |
| V _e | Effective volume | 800mm ³ |
| l _e | Effective length | 20.3mm |
| A _e | Effective area | 39.5mm ² |
| μ _e | Effective permeability | 123 (P6142-1) 154 (P6142-2) |
| m | Mass | 4.1g |

Transformer schematic

Fig 1

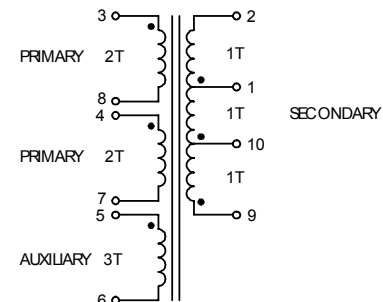

APPLICATION SCHEMATICS

In the flyback converter topology, the transformer operates as an energy storage element, and the ferrite core of P6142 is gapped to avoid saturation. The variants P6142-1 and P6142-2 differ in their gap sizes to suit particular applications and switching frequencies. P6142-2 is recommended for frequencies from 100kHz to 350kHz; P6142-1 is recommended for frequencies from 350kHz to 500kHz

Note that in the discontinuous conduction flyback mode, the output load current flows when the switch is open. Observe winding polarities.

The auxiliary winding may be used to provide a power rail for switching and control circuits. In the schematics below, switch drive circuitry and feedback components are omitted for simplicity.

24V operation (22–32V)

For 24V operation the transformer primaries are connected in series, giving nominal primary inductance of 4 μ H (P6142-1) and 5 μ H (P6142-2), and primary DCR of 14m Ω .

Fig 2 shows a typical schematic with a 15V @ 1A output. For a 5V output, use the output tap as shown in fig 3.

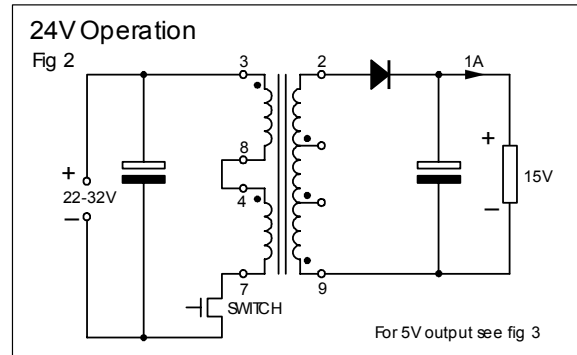

12V operation (10–22V)

For 12V operation the transformer primaries are connected in parallel, giving nominal primary inductance of 1 μ H (P6142-1) and 1.26 μ H (P6142-2), and primary DCR of 3.5m Ω .

Fig 3 shows a typical schematic with a 5V @ 3A output. For a 15V output, use the output tap as shown in fig 2.

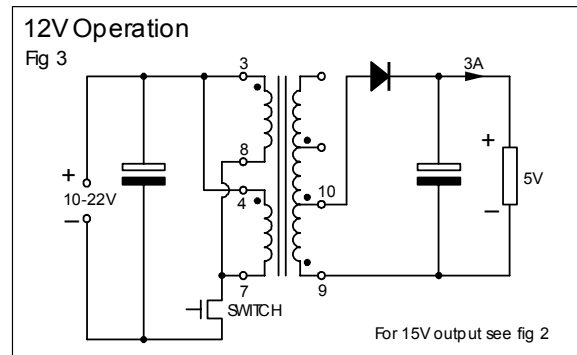

Multiple output

Following the examples given in figs 2 and 3, the secondary taps can be utilized to provide multiple output voltages. For example, fig 4 shows a 24V input flyback converter with +10V and \pm 5V outputs. Other combinations are possible.

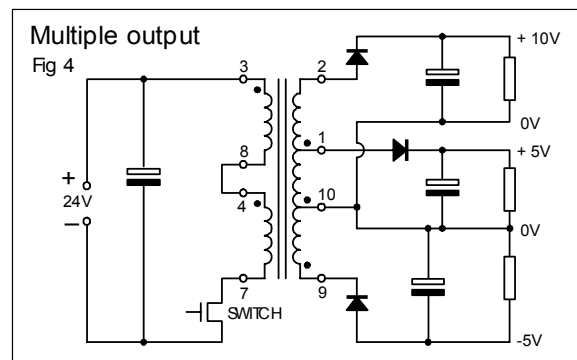

CONSTRUCTION

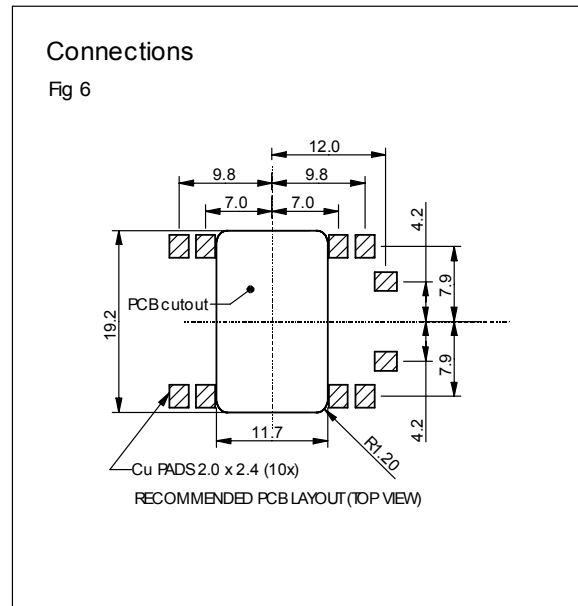
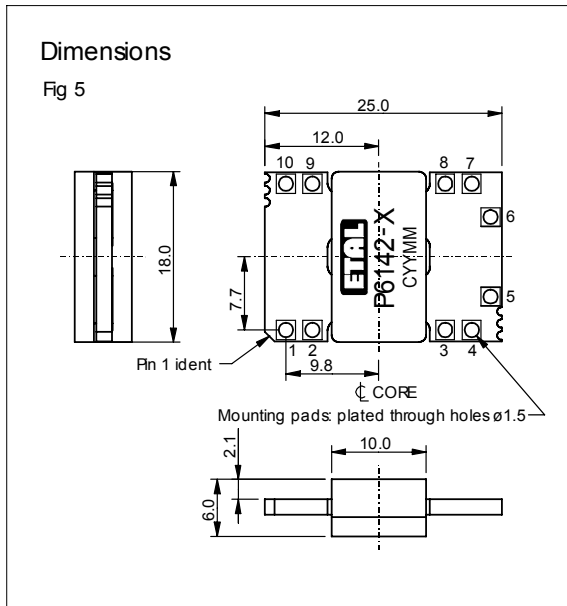

ORDERING CODE

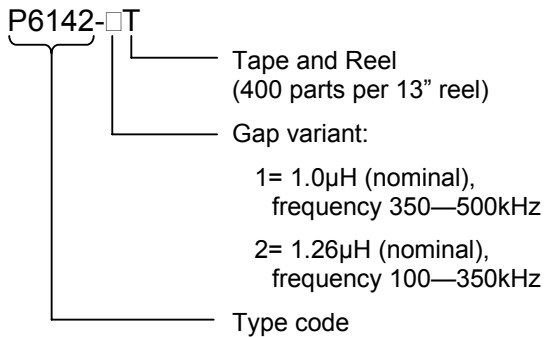

ABSOLUTE MAXIMUM RATINGS

(Ratings of components independent of circuit).

| | |
|--|----------------------------|
| Short term isolation voltage (1s) | 500Vrms |
| Peak primary current (per primary winding) | 12A P6142-1 10A P6142-2 |
| V.µs per primary winding | 11V.µs (for ΔB=135mT) |
| Storage temperature | +85°C |
| Magnetic Core temperature | 120°C |
| Reflow temperature (10s) | 260°C |