

VICOR CONFIDENTIAL

THIS DOCUMENT AND THE DATA DISCLOSED HEREIN OR HEREWITH IS NOT TO BE REPRODUCED, USED, OR DISCLOSED IN WHOLE OR IN PART TO ANYONE WITHOUT PERMISSION OF VICOR CORP.

REV.	DESCRIPTION	DATE	APPROVED
C	DRAWN & REL E920579	J.W. 10/6/92	JJG
D	REVISED PER E940532	RCM 8/10/94	DPK
E	REVISED PER E970468	RCM 11/25/97	DPK

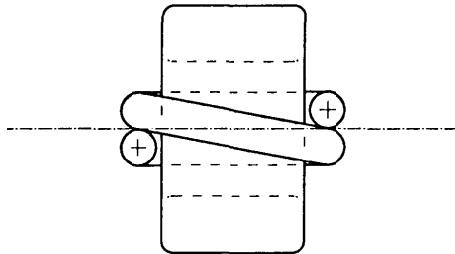
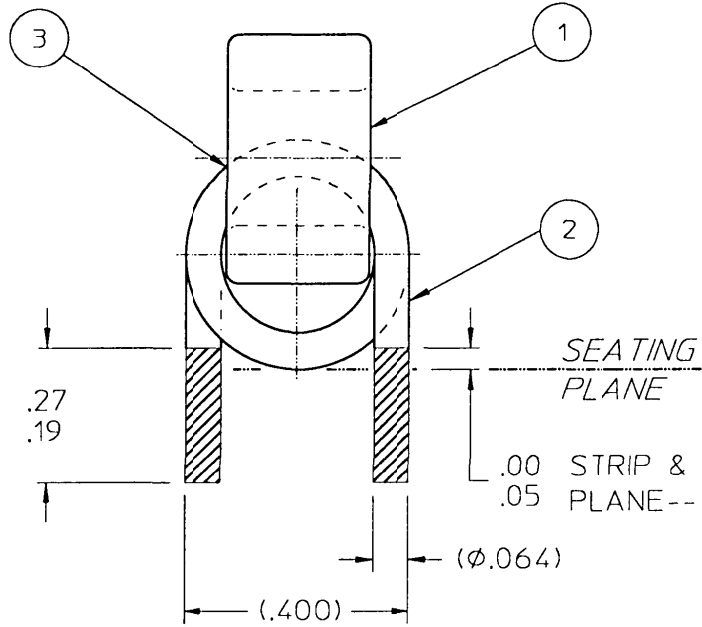

VICOR

ORIGINAL ONLY WHEN STAMPED IN RED

3	A/R	-	81-00004	ADHESIVE, SICOMET 7000													
2	2.2	IN.	56-00002	WIRE, COPPER, SOLID. #14AWG, MAGNET													
1	1	EA	36-00003	CORE, .2uH, OUTPUT	MICROMETALS-T38-26												
ITEM	QTY.	J/M	PART NO.	DESCRIPTION	MAT'L. SPEC.												
UNLESS OTHERWISE SPECIFIED DIMENSIONS ARE IN INCHES TOLERANCES ARE:				<table border="1"> <thead> <tr> <th colspan="2">APPROVALS</th> <th>DATE</th> </tr> </thead> <tbody> <tr> <td>DRAWN:</td> <td></td> <td>10/92</td> </tr> <tr> <td></td> <td></td> <td></td> </tr> <tr> <td></td> <td></td> <td></td> </tr> </tbody> </table>		APPROVALS		DATE	DRAWN:		10/92						
APPROVALS		DATE															
DRAWN:		10/92															
FRACTIONS DECIMALS ANGLES ± 1/64 .XX ± .03 ± 1° .XXX ± .010				<p>INDUCTOR ASSY, OUTPUT, .2 uH</p>													
THIRD ANGLE PROJECTION																	
				SIZE	FSCM NO.												
DO NOT SCALE DRAWING				B	67131												
				DWG. NO.	REV.												
				05298	E												
				SCALE 4X	SHEET 1 OF 1												