

DESCRIPTION

The System Sensor 2451 Series photoelectronic smoke detectors are specifically designed to meet the performance requirements of fire detection/alarm systems. The 2451 and 2451T detectors use state-of-the-art optical sensing chambers and are designed so that LED failure will not cause an alarm. The detectors are designed to provide open area detection and when installed in a two-wire base are compatible with FCI fire alarm control panels. The detectors operation and sensitivity can be tested in place. The Model 2451T unit has the same specifications as the Model 2451, but also features a built-in fixed temperature (135° F) thermal detection unit.

The detectors are of plug-in construction and plug into the same base as the 1451 series ionization smoke detectors, making both models interchangeable. Bases are available for two-wire, four-wire, and 120 VAC four-wire operation.

Two visible LEDs on each detector flash every ten seconds indicating that power is being applied to the detector. The LEDs light steadily when the detector is in alarm. A remote LED annunciator is available as an optional accessory.

The 2451 is UL Listed for mounting inside ducts up to a velocity of 3,000 FPM.

Sensitivity testing is performed either by applying a test magnet or inserting a calibrated test card according to the test procedures. Field metering of detector sensitivity may be performed with the aid of a voltmeter and Test Kit, MOD 400R.



FEATURES

- Easy plug-in of the Head to Base**
- Built-in Tamper-resistant Feature**
- Built-in Test Switch**
- Built-in Visual Alarm Indicators**
- 360° View Angle Of Alarm LEDs**
- Compatible with FCI Control Panels**
- Field Metering of Detector Sensitivity**
- Removable Insect Screen and Cover for Field Cleaning**
- Sealed against Dirt, Insects, and Back Pressure**
- Insect-resistant screening (.020"/.508 mm openings)**

APPROVALS



TECHNICAL SPECIFICATIONS

Nominal sensitivity	3.0 %/ft.
Operating voltage	8.5 - 35 VDC (24 VDC nominal)
Operating temperature	32° to- 120° F (0° to 49° C)
Operating humidity	0 % - 93 % relative humidity
Air velocity	3,000 feet per minute maximum
Construction	Off-white flame retardant plastic
Diameter	6.2 inches (15.7 cm)
Height	3.3 inches (8.2 cm)
Weight	0.5 lb. (277 g)

MOUNTING

On a 4-inch square box with or without plaster ring or supplied adapter. Minimum depth 1.5 inches.

On a 3 1/2 or 4-inch octagonal box. Minimum depth 1.5 inches.

On a single gang box. Min. depth 1.5 inches.

INSTALLATION

Place the detector into the detector base. Turn the detector clockwise until the detector locks into place.

To use the tamper-proof feature, break the smaller tab on the scribed line in the tamper proof tab located on the detector mounting bracket. Install the detector. To remove the detector from the base when using the tamper-proof feature, insert the blade of a small screwdriver into the hole on the side of the base and push the plastic lever away from the detector head. This will allow the detector to be rotated counterclockwise for removal. **NOTE:** The decorative ring must be removed in order to remove the head when using the tamper-proof feature.

The tamper-proof feature may be defeated permanently by breaking the plastic lever off the base.

NOTE: The number of two-wire smoke detectors which can be accommodated per zone varies with different control panels. **Consult the control panel instruction manual to determine the capacity.**

Refer to NFPA 72, Chapter 5-3 "Smoke Sensing Fire Detectors" for spacing, location of detectors and other guidelines.

TESTING

Detectors may be tested in the following ways:

Place a test magnet against the cover opposite the test module socket (See illustration above). The detector should go into alarm within 5 seconds.

A test card with one end marked "ALARM" and the other end marked "NO ALARM" is furnished with each unit. For the complete procedure, refer to the Installation and Maintenance instructions furnished with each detector.

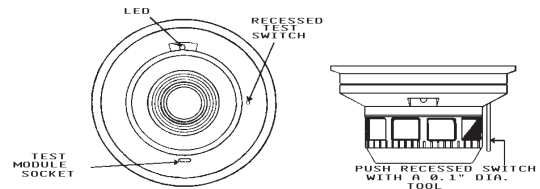

VIEWS SHOWING POSITION OF TEST MAGNET

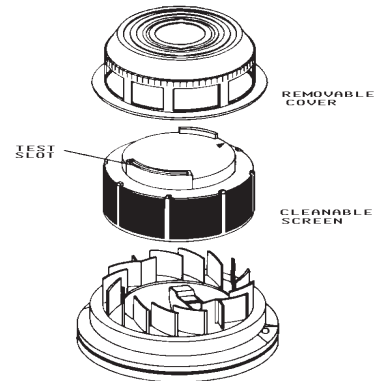

WARNING: To prevent detector contamination during construction, smoke detectors must be protected from dust and contamination until area is clean and dust free. See NFPA 72-5-3.7.1.3.

Field metering of detector sensitivity may be performed with the aid of a voltmeter and Test Kit MOD 400R.

For the complete procedure, refer to the Installation and Maintenance instructions furnished with each detector.

MAINTENANCE

Cleaning programs should be adapted to the individual environment in conformance with NFPA Standard 72. We recommend, at the least, an annual cleaning of the unit. The detector screen and cover assembly can be removed, revealing the sensing chamber. A vacuum cleaner can be used to remove dust from the screen, cover and sensing chamber. For the complete procedure, refer to the Installation and Maintenance instructions furnished with each detector.

ORDERING AND TECHNICAL INFORMATION

Part No.	Model	Supv. Current	Alarm Current	Contacts	Description
	2451	—	‡	—	Photoelectronic Detector
	2451T	—	‡	—	Photo. Detector w/135°F thermal
	B401B	.00012 A	‡	—	Base, two-wire
	B402B	.00012 A	.036 A	Form A, C*	Base, four-wire, 24 VDC operation
	301B4AC			Form A, C* & Supv.	Base, four-wire, 120 VAC operation
	RA-400		.007 A		Remote Alarm Indicator
	PAM-1		.015 A	Form B	End of Line Relay, 24 VDC
					Test Kit

* Resistive load (contact ratings): Form A - 2.0 A. @ 30 VAC/DC
Form C - 2.0 A. @ 30 VAC/DC, 1.0A. @ 120 VAC

‡NOTE: Alarm current of detector is limited by control panel initiating device circuit.

Specifications are provided for information only, are not intended to be used for installation purposes, and are believed to be accurate. However, no responsibility is assumed by Fire Control Instruments, Inc. for their use. Specifications subject to change without notice. © 2003 All Rights Reserved