

FILMTRIM[®] PLASTIC DIELECTRIC CAPACITORS

TYPES

- Six Dielectrics:
 - High temperature PTFE
 - Standard PTFE
 - Polypropylene
 - Polyimide
 - Polycarbonate
 - Polyphenyl sulfide
- SMD and lead-through-hole mounting
- Top, bottom and side mount models
- Wide capacitance ranges
- Compact sizes
- Low cost for commercial/industrial applications
- Linear capacitance change vs. rotation

APPLICATIONS

- Mobile Radios
- Transmitters
- Pagers
- Instruments
- Electronic Games
- Wireless Security and Fire Alarms
- CATV



MODIFICATIONS AND VARIATIONS AVAILABLE

- Special capacitance ranges
- Special terminal sizes and shapes
- Extended adjust shafts
- High temperature versions for PTFE
- Silver and/or gold plating



Sprague-Goodman Electronics, Inc.

1700 SHAMES DRIVE, WESTBURY, NY 11590

TEL: 516-334-8700 • FAX: 516-334-8771

E-MAIL: info@spraguegoodman.com

5mm TOP ADJUST

FEATURES

- High temperature PTFE or polyimide (PI) dielectrics
- Compact size
- Linear capacitance change vs. rotation

SPECIFICATIONS

Voltage Rating: 150 VDC
 Dielectric Withstanding Voltage: 300 VDC
 Contact Resistance: 0.010 Ohms max
 Insulation Resistance: 10⁴ megohms min
 Torque: 15 to 200 g-cm (0.21 to 3 oz-in)

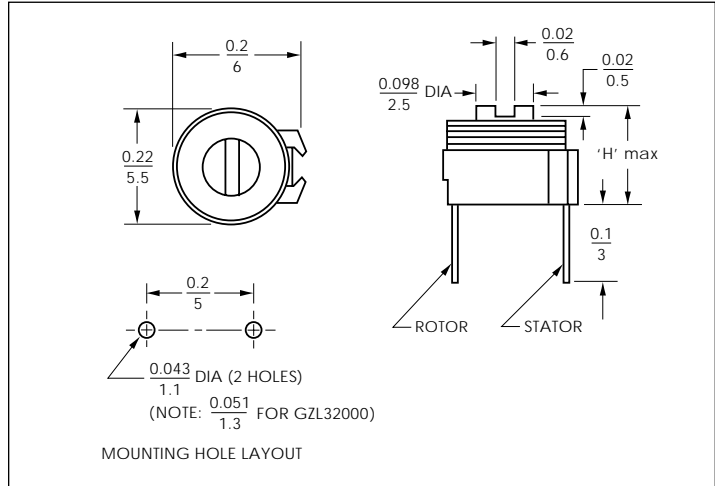

All dimensions are in /mm.



| Dielectric | Capacitance (pF) | | Q min (1MHz) | TCC (ppm / °C) | Operating Temperature (°C) | 'H' max in/mm | Color Code | Model Number |
|-----------------|------------------|------|--------------|----------------|----------------------------|---------------|------------|--------------|
| | min | max | | | | | | |
| PTFE, High Temp | 1.2 | 4.0 | 1500 | 0 ± 350 | -40 to +125 | 0.20 / 5.0 | Brown | GXL4R000 |
| | 1.8 | 10.0 | 1500 | 0 ± 300 | -40 to +125 | 0.23 / 5.8 | Black | GXL10000 |
| | 2.0 | 15.0 | 1500 | 0 ± 300 | -40 to +125 | 0.24 / 6.0 | White | GXL15000 |
| | 2.3 | 18.0 | 1500 | 0 ± 300 | -40 to +125 | 0.24 / 6.0 | Green | GXL18000 |
| PI | 1.2 | 5.0 | 150 | 0 ± 350 | -40 to +85 | 0.20 / 5.0 | Brown | GZL5R000 |
| | 1.4 | 10.0 | 150 | 0 ± 350 | -40 to +85 | 0.20 / 5.0 | Black | GZL10000 |
| | 2.0 | 15.0 | 150 | 0 ± 250 | -40 to +85 | 0.23 / 5.8 | White | GZL15000 |
| | 2.7 | 20.0 | 150 | 0 ± 250 | -40 to +85 | 0.23 / 5.8 | Green | GZL20000 |
| | 3.6 | 32.0 | 150 | 0 ± 250 | -40 to +85 | 0.25 / 6.3 | None | GZL32000 |

ECONOMY 7 mm TOP ADJUST

SPECIFICATIONS

Operating Temperature Range: -25°C to +85°C
 Dielectric: Polyphenyl Sulfide
 Voltage Rating: 50 VDC
 Dielectric Withstanding Voltage: 100 VDC
 Insulation Resistance: 500 megohms min
 Torque: 20 - 200 g-cm (0.28 - 2.8 oz-in)

FEATURES

- Low setting drift
- High Q
- Low cost
- Compact size

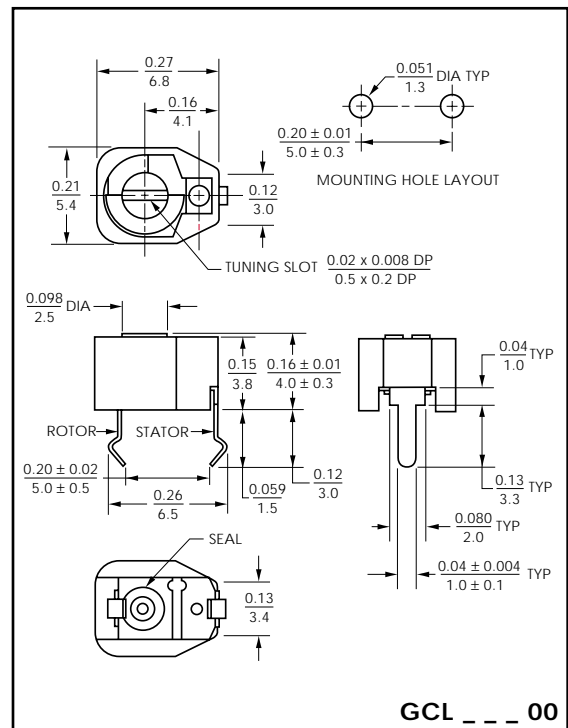

| Capacitance (pF) | | TCC (ppm / °C) | Q min (1 MHz) | Color Code | Bulk Pack Model Number | Ammo Pack Model Number |
|------------------|------|----------------|---------------|------------|------------------------|------------------------|
| min | max | | | | | |
| 0.7 | 10.0 | 350 ± 500 | 500 | Brown | GCL10000 | GCL10025 |
| 0.8 | 20.0 | 350 ± 500 | 500 | Green | GCL20000 | GCL20025 |
| 0.9 | 30.0 | 350 ± 500 | 500 | Yellow | GCL30000 | GCL30025 |
| 1.0 | 40.0 | 350 ± 500 | 500 | Blue | GCL40000 | GCL40025 |

7 mm SURFACE MOUNT

FEATURES

- Low setting drift
- High Q
- Low cost
- Linear Capacitance change vs. rotation
- Compact size



| Capacitance (pF) | | 'H' max (in/mm) | Color Code | Model Number |
|------------------|------|-----------------|------------|--------------|
| min | max | | | |
| 0.5 | 4.5 | 0.087 / 2.2 | Orange | GSX364 |
| 0.6 | 9.0 | 0.087 / 2.2 | Black | GSX358 |
| 0.8 | 15.0 | 0.094 / 2.4 | Blue | GSX365 |
| 1.0 | 20.0 | 0.100 / 2.6 | Green | GSX366 |

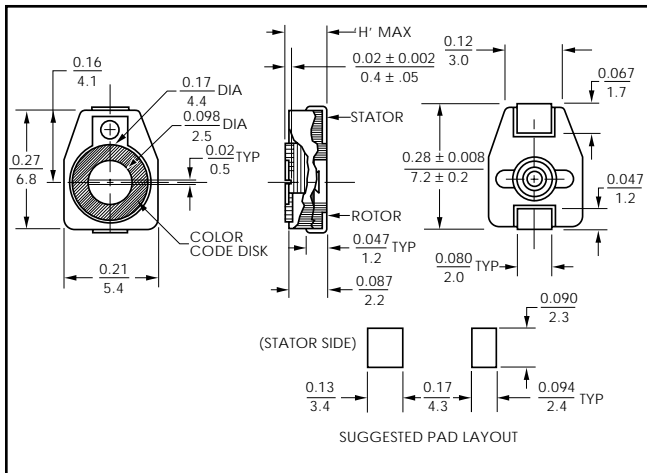

SPECIFICATIONS

Q min (at 10 MHz): 1000
 Operating Temperature Range: -25°C to +85°C
 Dielectric: PTFE
 TCC: N100 ± 100 ppm/°C
 Voltage Rating: 100 VDC
 Dielectric Withstanding Voltage: 200 VDC
 Insulation Resistance: 10⁴ megohms min
 Torque: 20-300 g-cm (0.28 - 4.2 oz-in)

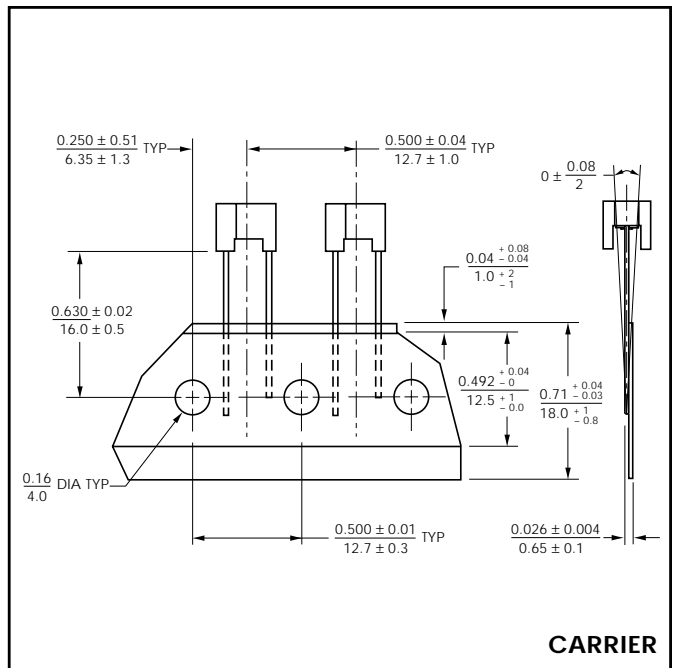
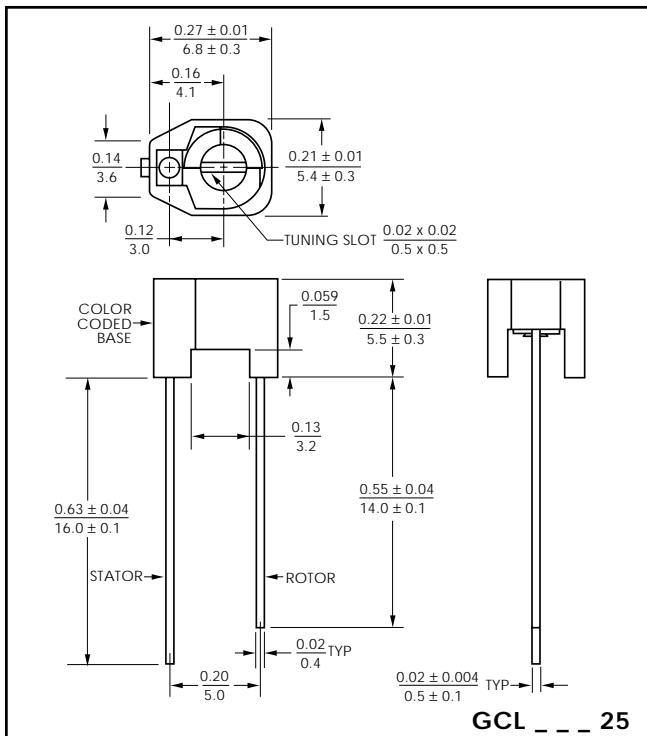
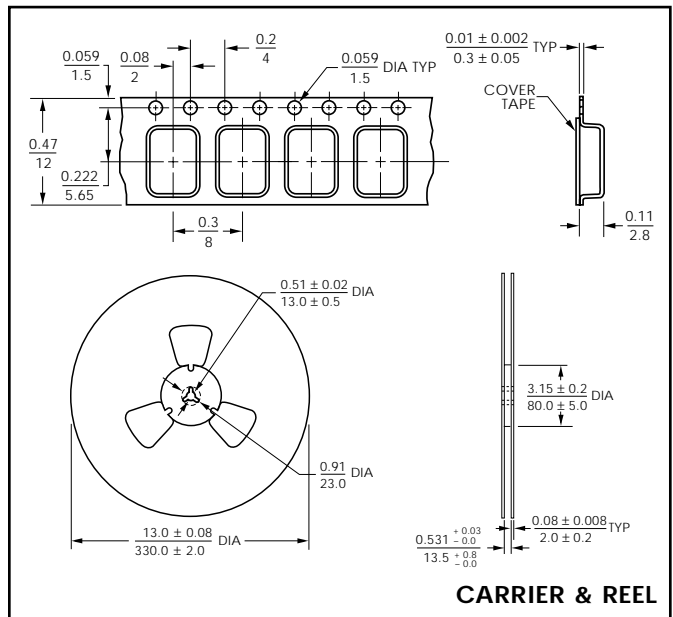

All dimensions are in / mm.

7 mm SURFACE MOUNT NONMAGNETIC

FEATURES

- Low setting drift
- High Q
- Low cost
- Linear Capacitance change vs. rotation
- Compact size

SPECIFICATIONS

Relative Permeability: 1.0025 max
 Q min (at 10 MHz): 1000
 Operating Temperature Range: -25°C to +85°C
 Dielectric: PTFE
 TCC: N100 ± 100 ppm/°C
 Voltage Rating: 100 VDC
 Dielectric Withstanding Voltage: 200 VDC
 Insulation Resistance: 10⁴ megohms min
 Torque: 20-300 g-cm (0.28 - 4.2 oz-in)



| Capacitance (pF) | | 'H' max (in/mm) | Color Code | Model Number |
|------------------|------|-----------------|------------|--------------|
| min | max | | | |
| 0.5 | 4.5 | 0.087 / 2.2 | Orange | GSX364NM |
| 0.6 | 9.0 | 0.087 / 2.2 | Black | GSX358NM |
| 0.8 | 15.0 | 0.094 / 2.4 | Blue | GSX365NM |
| 1.0 | 20.0 | 0.100 / 2.6 | Green | GSX366NM |

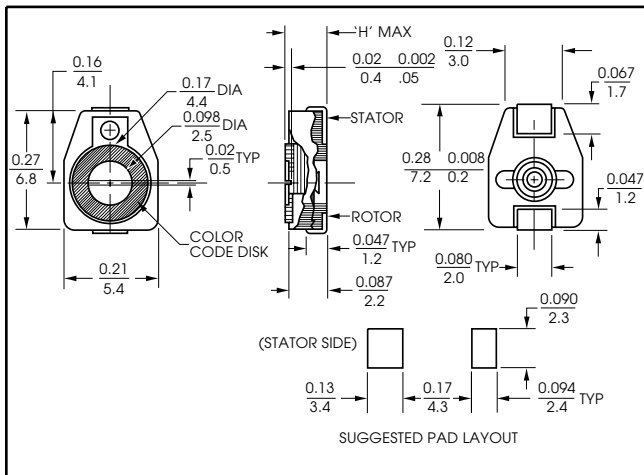

All dimensions are in / mm.

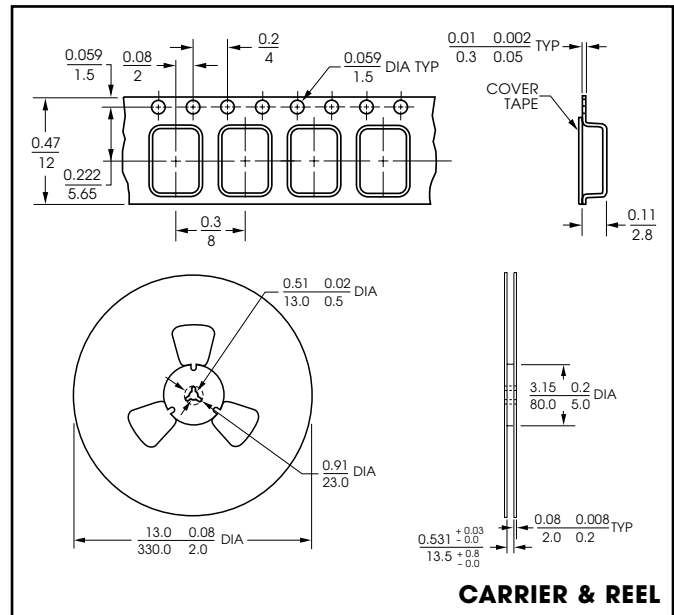

CARRIER & REEL



6 X 8 mm TOP/BOTTOM & SIDE ADJUST

FEATURES

- Compact size
- High temperature PTFE dielectric
- Linear capacitance change vs. rotation

SPECIFICATIONS

Voltage Rating: 300 VDC

Dielectric Withstanding Voltage: 500 VDC

Contact Resistance: 0.010 Ohms max

Insulation Resistance: 10⁴ megohms min

Torque: 15 to 245 g-cm (0.21 to 3.4 oz-in)



| Dielectric | Capacitance (pF) | | Q min (1MHz) | TCC (ppm / °C) | Operating Temperature (°C) | Color Code | Top/Bottom Adjust | Top/Bottom Adjust | Side Adjust Model Number |
|-----------------|------------------|------|--------------|----------------|----------------------------|------------|---------------------|---------------------|--------------------------|
| | min | max | | | | | 3 Lead Model Number | 2 Lead Model Number | |
| PTFE, High Temp | 1.0 | 3.5 | 1500 | 0 ± 350 | -40 to +125 | Orange | GXE3R511 | GXE3R501 | GXQ3R501 |
| | 1.8 | 10.0 | 1500 | 0 ± 350 | -40 to +125 | White | GXE10011 | GXE10001 | GXQ10001 |
| | 2.5 | 18.0 | 1500 | 0 ± 350 | -40 to +125 | Red | GXE18011 | GXE18001 | GXQ18001 |

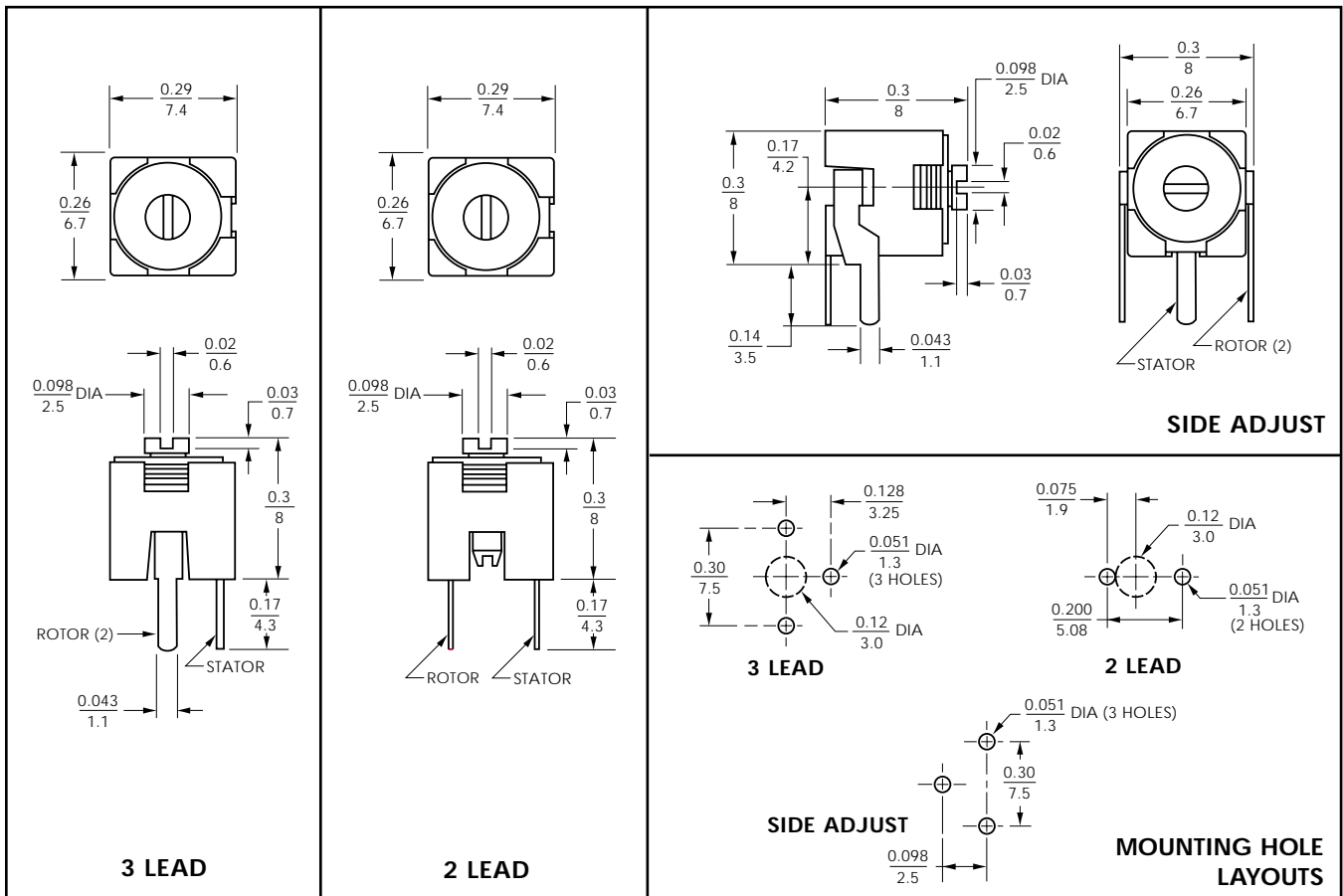

All dimensions are in / mm.

8 mm TOP/BOTTOM & SIDE ADJUST

SPECIFICATIONS

Voltage Rating: 200 VDC (High temp PTFE),
100 VDC (all others)

Dielectric Withstanding Voltage:
300 VDC (High temp PTFE), 200 VDC (all others)

Contact Resistance: 0.010 Ohms max

Insulation Resistance: 10⁴ megohms min

Torque: 15 to 250 g-cm (0.21 to 3.5 oz-in)

FEATURES

- Choice of dielectrics: High Temp PTFE, Standard PTFE, Polypropylene, or Polycarbonate
- Linear capacitance change vs. rotation



| Dielectric | Capacitance (pF) | | Q min (1MHz) | TCC (ppm/°C) | Operating Temperature (°C) | 'H' max in/mm | Color Code | Top/Bottom Adjust | Top/Bottom Adjust | Side Adjust |
|------------------|------------------|------|--------------|--------------|----------------------------|---------------|------------|---------------------|---------------------|--------------|
| | min | max | | | | | | 3 Lead Model Number | 2 Lead Model Number | Model Number |
| PTFE*, High Temp | 1.5 | 5.0 | 1500 | 0 ± 250 | -40 to +125 | .402/10.2 | Clear | GXE5R000 | GXE5R002 | GXR5R000 |
| | 1.8 | 9.0 | 1500 | 0 ± 250 | -40 to +125 | .402/10.2 | Yellow | GXE9R000 | GXE9R002 | GXR9R000 |
| | 2.6 | 18.0 | 1500 | 0 ± 250 | -40 to +125 | .402/10.2 | Green | GXE18000 | GXE18002 | GXR18000 |
| | 3.5 | 27.0 | 1500 | 0 ± 250 | -40 to +125 | .402/10.2 | Red | GXE27000 | GXE27002 | GXR27000 |
| | 4.5 | 36.0 | 1500 | 0 ± 250 | -40 to +125 | .449/11.4 | Violet | GXE36000 | GXE36002 | GXR36000 |
| | 5.0 | 45.0 | 1500 | 0 ± 250 | -40 to +125 | .449/11.4 | Orange | GXE45000 | GXE45002 | GXR45000 |
| PTFE | 1.6 | 5.0 | 1500 | 0 ± 350 | -40 to +85 | .402/10.2 | Clear | GXA5R000 | GXA5R002 | GXB5R000 |
| | 2.0 | 9.0 | 1500 | 0 ± 350 | -40 to +85 | .402/10.2 | Yellow | GXA9R000 | GXA9R002 | GXB9R000 |
| | 2.0 | 18.0 | 1500 | 0 ± 300 | -40 to +85 | .402/10.2 | Green | GXA18000 | GXA18002 | GXB18000 |
| | 3.9 | 27.0 | 1500 | 0 ± 300 | -40 to +85 | .402/10.2 | Red | GXA27000 | GXA27002 | GXB27000 |
| | 4.5 | 36.0 | 1500 | 0 ± 300 | -40 to +85 | .449/11.4 | Violet | GXA36000 | GXA36002 | GXB36000 |
| | 5.0 | 45.0 | 1500 | 0 ± 300 | -40 to +85 | .449/11.4 | Orange | GXA45000 | GXA45002 | GXB45000 |
| PP | 1.6 | 5.0 | 1000 | 0 ± 300 | -40 to +70 | .402/10.2 | Clear | GYA5R000 | GYA5R002 | GYB5R000 |
| | 2.0 | 10.0 | 1000 | 0 ± 300 | -40 to +70 | .402/10.2 | Yellow | GYA10000 | GYA10002 | GYB10000 |
| | 2.0 | 15.0 | 1000 | 0 ± 400 | -40 to +70 | .402/10.2 | Blue | GYA15000 | GYA15002 | GYB15000 |
| | 2.2 | 22.0 | 1000 | 0 ± 400 | -40 to +70 | .402/10.2 | Green | GYA22000 | GYA22002 | GYB22000 |
| | 2.3 | 27.0 | 1000 | 0 ± 350 | -40 to +70 | .402/10.2 | Red | GYA27000 | GYA27002 | GYB27000 |
| | 3.0 | 36.0 | 1000 | 0 ± 300 | -40 to +70 | .402/10.2 | Violet | GYA36000 | GYA36002 | N/A |
| PC | 2.5 | 30.0 | 200 | 100 ± 300 | -40 to +85 | .402/10.2 | Red | GZA30000 | GZA30002 | GZB30000 |
| | 4.0 | 40.0 | 200 | 100 ± 300 | -40 to +85 | .402/10.2 | Violet | GZA40000 | GZA40002 | GZB40000 |

* Gold plated metal parts are standard on GXE and GXR models shown above.

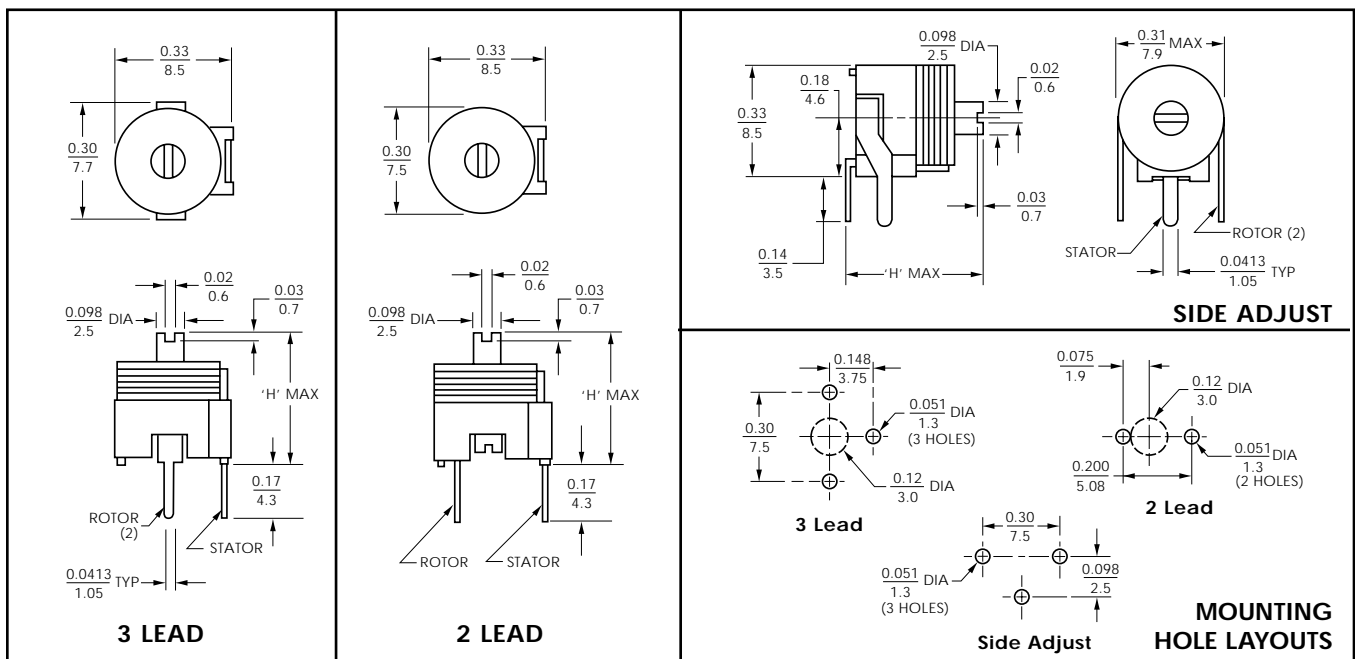

All dimensions are in / mm.

10 mm TOP/BOTTOM & SIDE ADJUST

SPECIFICATIONS

Voltage Rating: 200 VDC (High temp PTFE),
100 VDC (all others)

Dielectric Withstanding Voltage:
300 VDC (High temp PTFE), 200 VDC (all others)

Contact Resistance: 0.010 Ohms max

Insulation Resistance: 10⁴ megohms min

Torque: 15 to 360 g-cm (0.2 to 5 oz-in)

FEATURES

- Choice of dielectrics: High Temp PTFE, Standard PTFE, Polypropylene (PP), or Polycarbonate (PC)
- Linear capacitance change vs. rotation
- Wide capacitance ranges

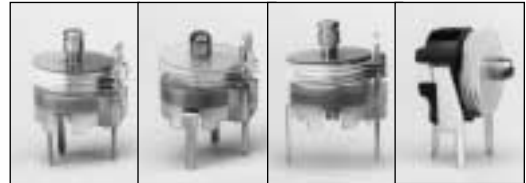

| Dielectric | Capacitance (pF) | | Q min (1MHz) | TCC (ppm/°C) | Operating Temperature (°C) | 'H' max in/mm | Color Code | Top/Bottom | Top/Bottom | Top/Bottom | Side |
|------------------|------------------|-------|--------------|--------------|----------------------------|---------------|------------|-----------------------|------------------------|-------------------|-----------|
| | min | max | | | | | | 3 Lead-Std. Model No. | 3 Lead-Spec. Model No. | 2 Leads Model No. | Model No. |
| PTFE*, High Temp | 2.5 | 15.0 | 1500 | 0 ± 250 | -40 to +125 | 0.402/10.2 | Red | GXF15000 | GXF15003 | GXF15004 | GXT15000 |
| | 3.0 | 25.0 | 1500 | 0 ± 250 | -40 to +125 | 0.402/10.2 | Clear | GXF25000 | GXF25003 | GXF25004 | GXT25000 |
| | 4.0 | 40.0 | 1500 | 0 ± 250 | -40 to +125 | 0.402/10.2 | Yellow | GXF40000 | GXF40003 | GXF40004 | GXT40000 |
| | 5.5 | 60.0 | 1500 | 0 ± 250 | -40 to +125 | 0.449/11.4 | Blue | GXF60000 | GXF60003 | GXF60004 | GXT60000 |
| | 6.0 | 75.0 | 1500 | 0 ± 250 | -40 to +125 | 0.449/11.4 | Violet | GXF75000 | GXF75003 | GXF75004 | GXT75000 |
| | 8.0 | 90.0 | 1500 | 0 ± 250 | -40 to +125 | 0.488/12.4 | Orange | GXF90000 | GXF90003 | GXF90004 | GXT90000 |
| PTFE | 2.0 | 13.0 | 1500 | 0 ± 400 | -40 to +85 | 0.402/10.2 | Blue | GXC13000 | GXC13003 | GXC13004 | GXD13000 |
| | 3.0 | 26.0 | 1500 | 0 ± 350 | -40 to +85 | 0.402/10.2 | Green | GXC26000 | GXC26003 | GXC26004 | GXD26000 |
| | 3.5 | 38.0 | 1500 | 0 ± 300 | -40 to +85 | 0.402/10.2 | Clear | GXC38000 | GXC38003 | GXC38004 | GXD38000 |
| | 6.0 | 60.0 | 1500 | 0 ± 300 | -40 to +85 | 0.449/11.4 | Yellow | GXC60000 | GXC60003 | GXC60004 | GXD60000 |
| | 7.0 | 75.0 | 1500 | 0 ± 300 | -40 to +85 | 0.449/11.4 | Red | GXC75000 | GXC75003 | GXC75004 | GXD75000 |
| | 8.0 | 90.0 | 1500 | 0 ± 300 | -40 to +85 | 0.488/12.4 | Violet | GXC90000 | GXC90003 | GXC90004 | GXD90000 |
| 10.0 | 150.0 | 1500 | 0 ± 300 | -40 to +85 | 0.488/12.4 | Orange | GXC15100 | GXC15103 | GXC15104 | N/A | |
| PP | 2.0 | 15.0 | 1000 | 0 ± 400 | -40 to +70 | 0.402/10.2 | Blue | GYC15000 | GYC15003 | GYC15004 | GXD15000 |
| | 3.0 | 20.0 | 1000 | 0 ± 400 | -40 to +70 | 0.402/10.2 | Green | GYC20000 | GYC20003 | GYC20004 | GXD20000 |
| | 3.5 | 40.0 | 1000 | 0 ± 350 | -40 to +70 | 0.402/10.2 | Clear | GYC40000 | GYC40003 | GYC40004 | GXD40000 |
| | 4.5 | 65.0 | 1000 | 0 ± 350 | -40 to +70 | 0.402/10.2 | Yellow | GYC65000 | GYC65003 | GYC65004 | GXD65000 |
| PC | 8.0 | 80.0 | 200 | 0 ± 200 | -40 to +85 | 0.402/10.2 | Red | GZC80000 | GZC80003 | GZC80004 | GZD80000 |
| | 9.0 | 100.0 | 200 | 0 ± 400 | -40 to +85 | 0.449/11.4 | Violet | GZC10100 | GZC10103 | GZC10104 | GZD10100 |
| | 9.0 | 120.0 | 200 | 0 ± 350 | -40 to +85 | 0.449/11.4 | Orange | GZC12100 | GZC12103 | GZC12104 | GZD12100 |
| | 10.0 | 150.0 | 200 | 0 ± 350 | -40 to +85 | 0.472/12.0 | Orange | GZC15100 | GZC15103 | GZC15104 | GZD15100 |
| | 12.0 | 180.0 | 200 | 0 ± 350 | -40 to +85 | 0.472/12.0 | Orange | GZC18100 | GZC18103 | GZC18104 | GZD18100 |

* Gold plated metal parts are standard on GXF and GXT models shown above.

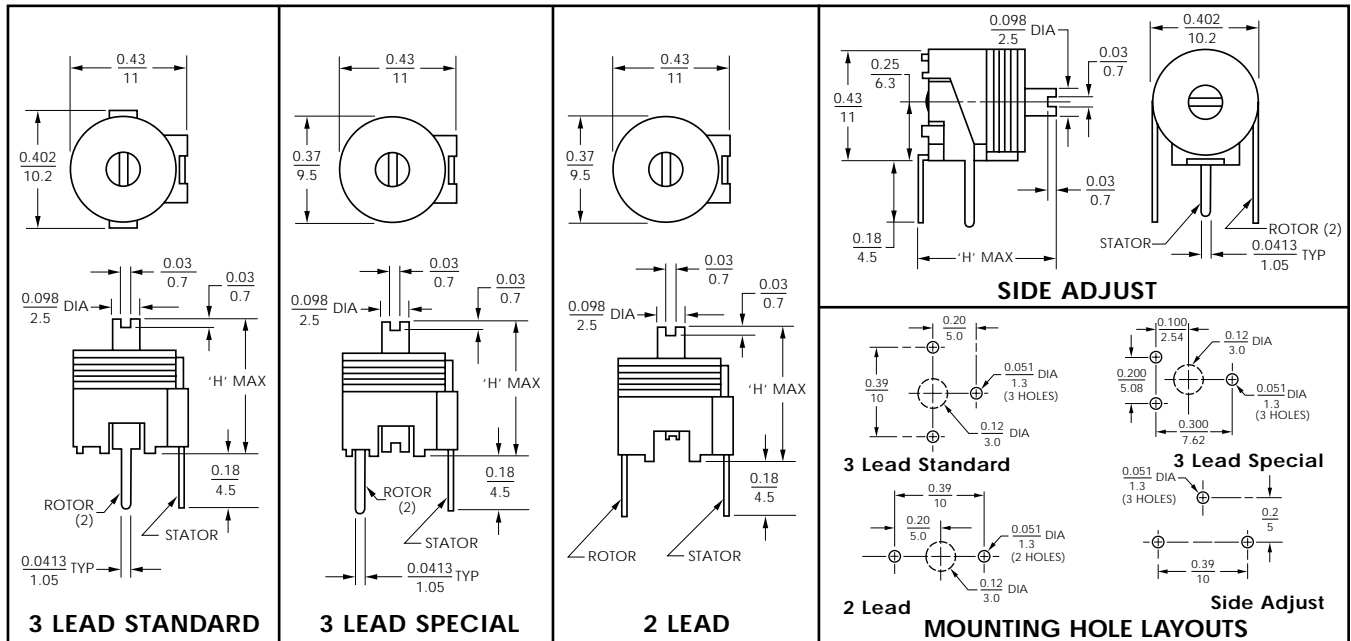

All dimensions are in / mm.

11 X 13 mm TOP/BOTTOM ADJUST

FEATURES

- Housing protected
- High capacitance range
- Linear capacitance change vs. rotation

SPECIFICATIONS

Voltage Rating: 100 VDC
 Dielectric Withstanding Voltage: 200 VDC
 Contact Resistance: 0.010 Ohms max
 Insulation Resistance: 10⁴ megohms min
 Torque: 20 to 360 g-cm (0.28 to 5 oz-in)

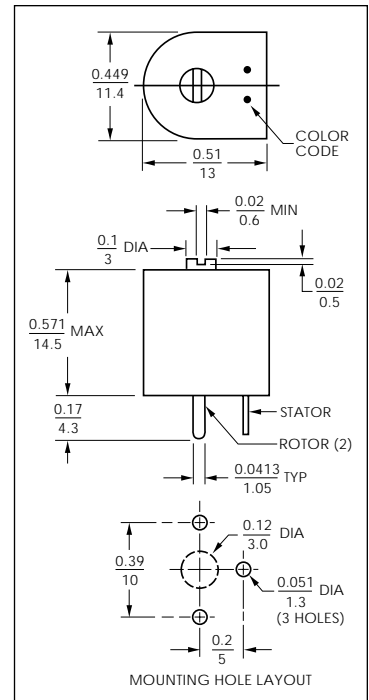

| Dielectric | Capacitance (pF) | | Q min (1MHz) | TCC (ppm/°C) | Operating Temperature (°C) | | Color Code | Model Number |
|------------|------------------|-------|--------------|--------------|----------------------------|------------|----------------|--------------|
| | min | max | | | -40 to +85 | -40 to +85 | | |
| PC | 15.0 | 230.0 | 200 | 0 ± 400 | -40 to +85 | | Orange - 1 dot | GZC23112 |
| | 30.0 | 430.0 | 150 | 0 ± 350 | -40 to +85 | | Orange - 2 dot | GZC43112 |

16 mm TOP / SIDE ADJUST

FEATURES

- Highest capacitance range
- Linear capacitance change vs. rotation

SPECIFICATIONS

Voltage Rating: 150 VDC
 Dielectric Withstanding Voltage: 300 VDC
 Contact Resistance: 0.010 Ohms max
 Insulation Resistance: 10⁴ megohms min
 Torque: 20 to 360 g-cm (0.28 to 5 oz-in)

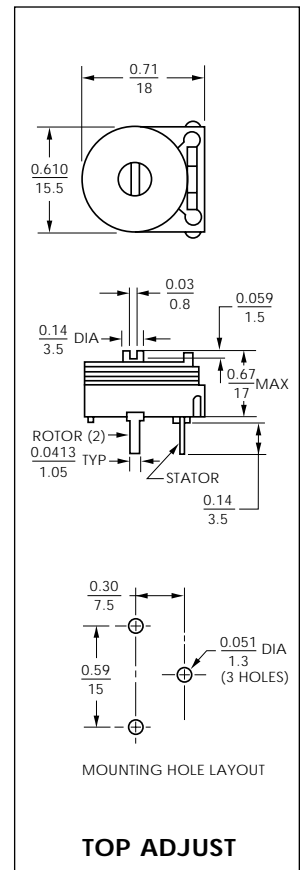
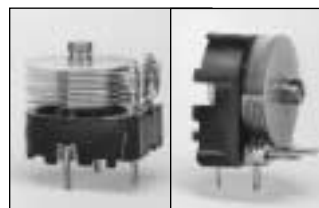
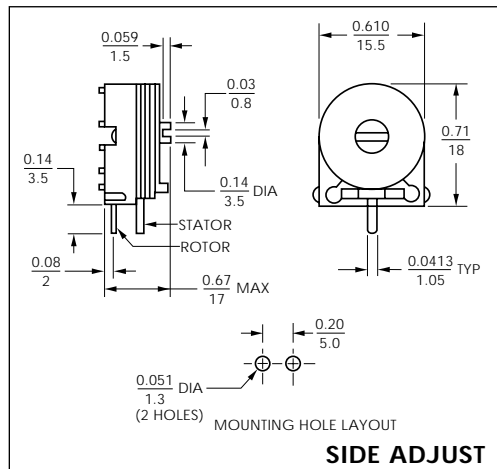

| Dielectric | Capacitance (pF) | | Q min (1MHz) | TCC (ppm/°C) | Operating Temperature (°C) | Color Code | Top Adjust | Side Adjust |
|------------|------------------|-------|--------------|--------------|----------------------------|------------|--------------|--------------|
| | min | max | | | | | Model Number | Model Number |
| PC | 9.0 | 200.0 | 200 | 0 ± 300 | -40 to +85 | Orange | GZN20100 | GZP20100 |
| | 18.0 | 300.0 | 200 | 0 ± 300 | -40 to +85 | Clear | GZN30100 | GZP30100 |
| PI | 25.0 | 600.0 | 150 | 0 ± 350 | -40 to +85 | None | GZN60100 | GZP60100 |

All dimensions are in / mm.



PART NUMBERING SYSTEM

| <u>GX</u> | | <u>A</u> | | <u>9R0</u> | <u>00</u> | |
|---------------|---|---------------|--|-----------------------------------|--------------------------------------|--|
| Dielectric | | Form Factor | | Cap Code | Modifications (Top Adjust Models) | |
| Symbol | Description | Symbol | Description | Industry Standard, i.e. | Symbol | Description |
| GC | PPS (Polyphenyl Sulfide) | A | 8 mm Top/Bottom Adjust | 1R6 = 1.6 pF, | 01 | 6 x 8 mm, 2 leads, GXE and GXQ series only |
| GSX** | PTFE (Polytetrafluor- oethylene) | B | 8 mm Side Adjust | 400 = 40.0 pF, | 02 | 8 mm, 2 leads |
| | | C | 10 mm Top/Bottom Adjust, 11 x 13 mm Top/Bottom Adjust | 301 = 300.0 pF | 03 | 10 mm, 3 lead, special |
| GX | PTFE (Polytetrafluor- oethylene) | D | 10 mm Side Adjust | | 04 | 10 mm, 2 leads |
| GY | PP (Polypropylene) | E* | 6 x 8 mm Top/Bottom Adjust, 8 mm Top/Bottom Adjust | | 11 | 6 x 8 mm, 3 leads |
| | | F* | 10 mm Top/Bottom Adjust | | 12 | 11 x 13 mm, housing protected (available on all 10 mm top and bottom adjust units) |
| GZ | PC or PI (Polycarbonate or Polyimide) | L | 5 mm Top Adjust, 7 mm Economy | | 25 | Ammo pack version for GCL only |
| | | N | 16 mm Top Adjust | | | |
| | | P | 16 mm Side Adjust | | | |
| | | Q* | 6 x 8 mm Side Adjust | | | |
| | | R* | 8 mm Side Adjust | | | |
| | | T* | 10 mm Side Adjust | | | |

* Extended temperature range: -40°C to +125°C

** GSX parts do not conform to part numbering system above.

For other modifications such as high temperature base material or special lead plating, contact factory.

SPECIFICATION NOTES

- Parts are 100% tested for capacitance range and dielectric withstanding voltage.
- Capacitance range specified is that which is guaranteed, and is measured at 1 MHz at room temperature.
- Q factor is measured at maximum rated capacitance and at room temperature.
- Dielectric strength is measured at maximum rated capacitance and room temperature, with test voltage (as listed for each model) applied for 60 seconds.
- Insulation resistance is measured at maximum rated capacitance and room temperature and at rated voltage, unless otherwise specified.
- Temperature coefficient of capacitance (TCC) is measured at 1 MHz over the operating temperature range, with capacitor set at maximum rated capacitance.
- Axial load during tuning should not exceed 200 grams force. At maximum axial load, capacitance change is no more than 15%.
- Capacitors should not be operated outside of rated capacitance range and working voltage.

Soldering and Cleaning

of FILMTRIM® Trimmer Capacitors

Soldering Methods

- Reflow soldering for GSX series
Pre-heat: 140°C ±10°C for 2 to 3 minutes.
Soldering: 200 to 250°C within 25 seconds.
(Peak soldering temperature: 250°C maximum).
- Dip soldering (does not apply to GSX models)
260°C ±10°C for 7 seconds maximum.
- Hand soldering (for lead-through-hole models)
Soldering: Tip temperature 350°C ±10°C for 3 to 4 seconds
- Hand soldering (GSX models)
Preheating: Fully preheat on a hot plate with a surface temperature of 100 to 150°C.
Soldering: 260°C ±10°C for 5 seconds maximum.

Cleaning

- Water soluble fluxes and detergents with a water flush after soldering of the boards can be used for GX, GY and GZ models.
- Do not immerse FILMTRIM models in chlorinated or fluorinated hydrocarbon solvents as this would adversely affect the plastic dielectrics and base materials. Some customers have successfully used GX models in scrubbers or sprayers where only the bottom of the printed circuit boards is exposed to solvents. If the process requires immersion in solvents for cleaning boards, the FILMTRIM capacitors should be hand soldered to board after the boards have been cleaned.

Mouser Electronics

Authorized Distributor

Click to View Pricing, Inventory, Delivery & Lifecycle Information:

Sprague Goodman:

[GXA18000](#) [GXC60003](#) [GYD65000](#) [GCL40000](#) [GXC60000](#) [GYA5R000](#) [GYA36000](#) [GXA36000](#) [GZL10000](#)
[GYB27000](#) [GZD80000](#) [GZD10100](#) [GZC23112](#) [GZD15100](#) [GYC40000](#) [GYC15000](#) [GSX364](#) [GSX366](#) [GSX365](#)
[GZC18100](#) [GZC18103](#) [GSX358](#) [GYB5R000](#) [GZD18100](#) [GCL30000](#) [GYD40000](#) [GZC80003](#) [GZC80000](#) [GYA15000](#)
[GYD20000](#) [GZC15100](#) [GYB22000](#) [GZC10100](#) [GCL20000](#) [GYA22000](#) [GZC12100](#) [GYA10000](#) [GYC20000](#)
[GYB10000](#) [GZL32000](#) [GYC65000](#) [GXA9R000](#) [GYB15000](#) [GCL10000](#) [GYD15000](#) [GZD12100](#) [GYA27000](#)
[GZN20100](#) [GXQ10001](#) [GXC90000](#) [GXL15000](#) [GZC10103](#) [GZC43112](#)