

LOW DISTORTION LINE MATCHING TRANSFORMER

P5056

Features

- * Lead-free (Pb-free)
- * RoHS compliant
- * Low Distortion
- * 11mm (0.43") Seated Height
- * Industry Standard Pinout
- * IEC 60950 and UL 60950 Certified
- * UL Recognized Component
- * Extended Frequency Response
- * Flat TX and RX Responses
- * Simple Matching
- * Low Insertion Loss
- * High Thermal Stability

Applications

- * V.90 and V.92 Modems
- * V.34 Modems
- * Fax Machines
- * Instrumentation
- * Set Top Box/Web browsing
- * Internet Feature Phones

DESCRIPTION

P5056 is intended for low cost V.90 and V.92 (56kbps) modems and other high-speed applications where low distortion at moderate power levels and very low voiceband frequencies is required.

P5056 uses patented design and construction methods to achieve excellent signal performance and safety isolation to international standards. The part is completely lead-free, compliant with RoHS Directive 2002/97/EC, and suitable for lead-free and conventional processing.

P5056 has exceptionally flat frequency response from 30Hz to 10kHz, a 3dB bandwidth of 60kHz and requires only the very simplest of matching to achieve good return loss and transhybrid loss across the voiceband, with very low levels of signal distortion at signal frequencies as low as 150Hz.

P5056 also exhibits stable characteristics over its full operating temperature range to maximize data throughput under varying environmental conditions without the need for modem retraining.

P5056 is certified to IEC 60950 and UL 60950. P5056 is a UL Recognized Component and is supported by an IEC CB certificate.

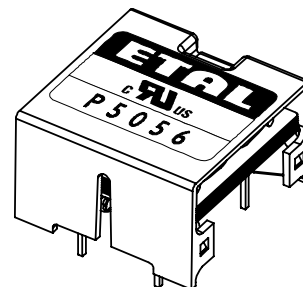

Patented



RoHS
COMPLIANT

SPECIFICATIONS

Electrical

At T = 25°C and as circuit Fig. 2 unless otherwise stated.

Parameter	Conditions	Min	Typ	Max	Units
Insertion Loss	f = 2kHz, R _L = 600Ω	-	1.6	-	dB
Frequency Response	LF -3dB cutoff	-	10	-	Hz
	HF -3dB cutoff	-	60	-	kHz
	100Hz – 4kHz	-	-	±0.1	dB
Return Loss ⁽⁵⁾	200Hz – 4kHz	20	-	-	dB
Transhybrid Loss ⁽⁵⁾	200Hz – 4kHz	-	20	-	dB
Third Harmonic Distortion ⁽¹⁾	150Hz -3dBm in line	-	-68	-	dBm
	200Hz -10dBm in line	-	-89	-	dBm
Balance	DC – 5kHz Method TG 25	80	-	-	dB
Voltage Isolation ⁽²⁾	50Hz	2.12	-	-	kVrms
	DC	3.0	-	-	kV
Operating Range:	Functional	0	-	+70	°C
	Storage	-40	-	+85	°C

Lumped equivalent circuit parameters as Fig. 1

DC resistance ⁽³⁾	Primary resistance R _{DCp}	92	-	114	Ω
	Secondary resistance R _{DCs}	88	-	108	Ω
Leakage inductance, ΔL		2.5	3.5	4.5	mH
Shunt inductance, L _p ⁽⁴⁾	200Hz 10mV	6	9	-	H
Shunt loss, R _p	200Hz 10mV	12	15	-	kΩ

Notes:

1. Third harmonic typically exceeds other harmonics by 10dB.
2. Components are 100% tested at 3.25kVDC.
3. Caution: do not pass DC through windings. Telephone line current must be diverted using semiconductor line hold circuit or choke.
4. At signal levels greater than 100mV, L_p will increase and R_p will decrease slightly but the effect is usually favourable to the return loss characteristic.
5. Return loss and transhybrid loss can be improved to 30dB in improved matching circuit. The values shown relate to the simplest configuration, Fig. 2.

Equivalent Circuit

Fig. 1

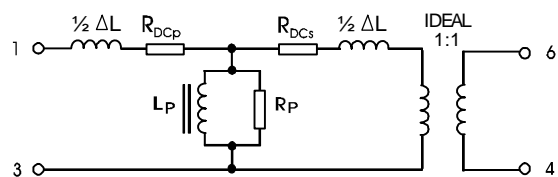

MATCHING RECOMMENDATIONS

The following recommendations start with the simplest implementations and progress to enhanced performance utilizing an additional component. Good performance is achieved even with the simplest configurations. The implementations assume a low impedance balanced TX drive and a relatively high impedance RX input, as is commonly available, though use with other TX/RX arrangements is straightforward. Note that there are no changes to components on the line side, or in the hybrid, whether 600Ω or complex reference impedance selected, thus assisting country configuration. For complex impedance, the matching circuits derived are suitable for reference impedances of the type 270 + 750//150nF e.g. European CTR21 and 220 + 820//120nF (or 115nF) e.g. Australia, South Africa, etc., and yield similar performance characteristics. For other impedances, please contact Profec Technologies.

Minimum Cost Implementations

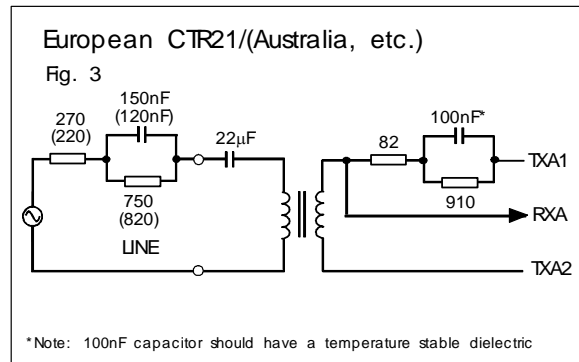
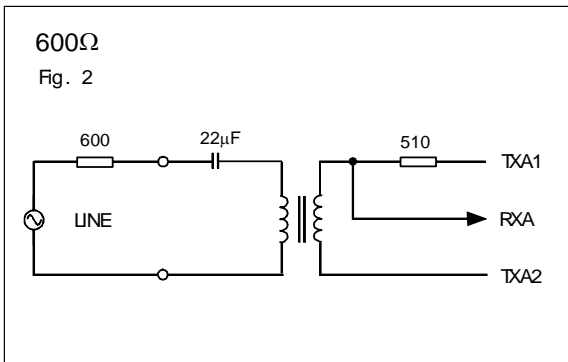

Improved matching

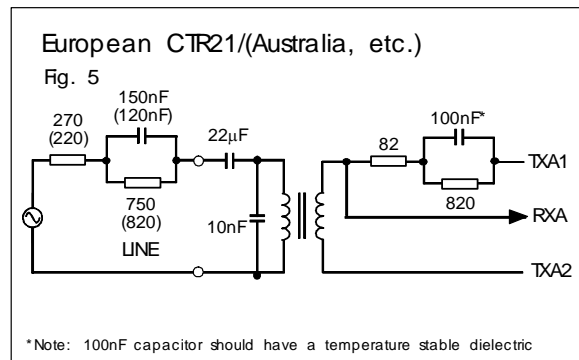
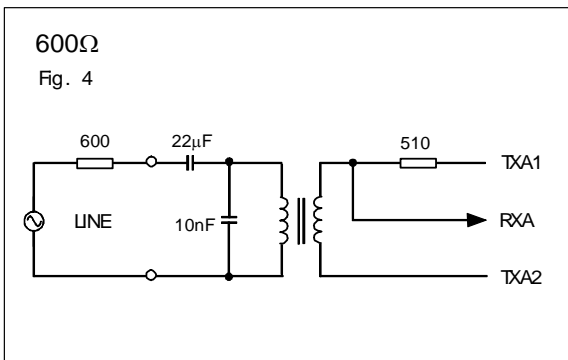

Patented

SAFETY

Constructed in accordance with IEC 60950-1, EN 60950-1 and UL 60950, supplementary insulation for a primary circuit, 250Vrms maximum working voltage, flammability class V-1.

CERTIFICATION

Certified under the IEC CB scheme (Certificate GB597W) to IEC 60950 Third Edition 1999 sub-clauses 1.5, 1.5.1, 1.5.2, 2.9, 2.9.1, 2.9.2, 2.9.3, 2.9.4, 2.9.5, 2.10, 2.10.1, 2.10.2, 2.10.3, 2.10.3.1, 2.10.3.2, 2.10.4, 2.10.5, 2.10.5.1, 2.10.5.2, 2.10.5.4, 4.7, 4.7.3, 4.7.3.1, 4.7.3.4, (Flammability Class V-1), 5.2, 5.2.1, and 5.2.2 for a maximum working voltage of 250Vrms, nominal mains supply voltage not exceeding 300Vrms and a maximum operating temperature of +85°C in Pollution Degree 2 environment, supplementary insulation for a primary circuit.

Recognized under the Component Recognition Program of Underwriters Laboratories Inc. to US and Canadian requirements CAN/CSA C22.2 No. 60950-1-03/UL60950-1, First Edition, based on IEC 60950-1, First Edition, maximum working voltage 250Vrms, Pollution Degree 2, supplementary insulation.

UL File number E203175.

Additionally, Profec Technologies certifies all transformers as providing voltage isolation of 2.12kVrms, 3kV DC minimum. All shipments are supported by a certificate of conformity to current applicable safety standards.

CONSTRUCTION

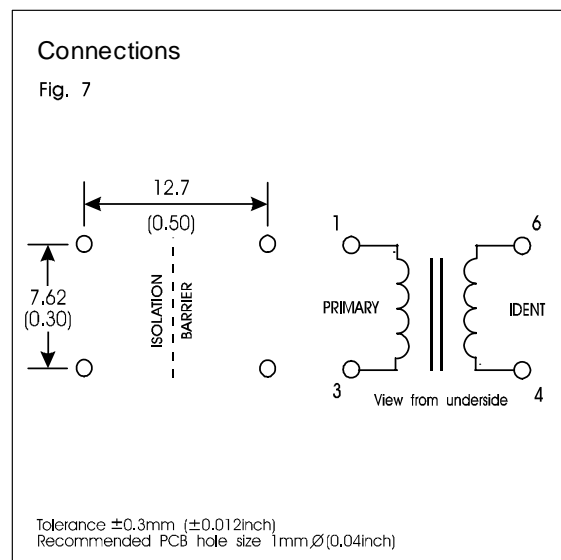
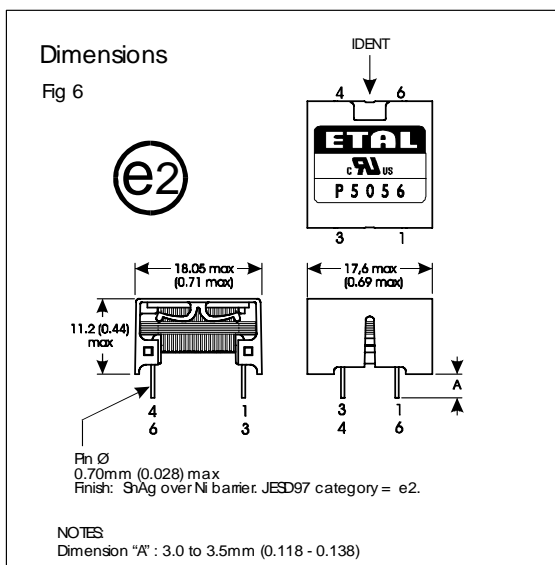

Dimensions shown are in millimetres (inches).
Geometric centres of outline and pin grid coincide within a tolerance circle of 0.6mm \varnothing .
Windings may be used interchangeably as primary or secondary.
Total weight typically 5.1g.

Patented

ABSOLUTE MAXIMUM RATINGS

(Ratings of components independent of circuit).

Short term isolation voltage (1s)	2.12kVrms, 3.0 kVDC
DC current	100µA
Storage temperature	-40°C to +85°C
Lead temperature, 10s	260°C

INTELLECTUAL PROPERTY RIGHTS

ETAL and P5056 are Trade Marks of Profec Technologies Ltd.

The Trade Mark ETAL is registered at the UK Trade Marks Registry.

Profec Technologies Ltd. is the owner of the design right under the Copyright Designs and Patents Act 1988 and no rights or licences are hereby granted or implied to any third party.

P5056 design and construction are protected by patents.

British Patent No. 2333646.

US Patent Nos. 6,344,787; 6,690,254.

European Patent No. 1082734

China Patent No. ZL 99806739.3

Other patents pending.

© 1998 - 2005 Profec Technologies Ltd.

Reproduction prohibited.



ISO 9001
FM 25326

ETAL Group Oy, Kuormatie 14, FIN-03101, Nummela
Telephone: +358 (0)20 7500 330 Fax: +358 (0)20 7500 333
Website: www.etalgroup.com Email: etalgroup@egruppen.com