

HE126XX52

1. EXTERNAL DIMENSION AND DISPLAY PATTERN

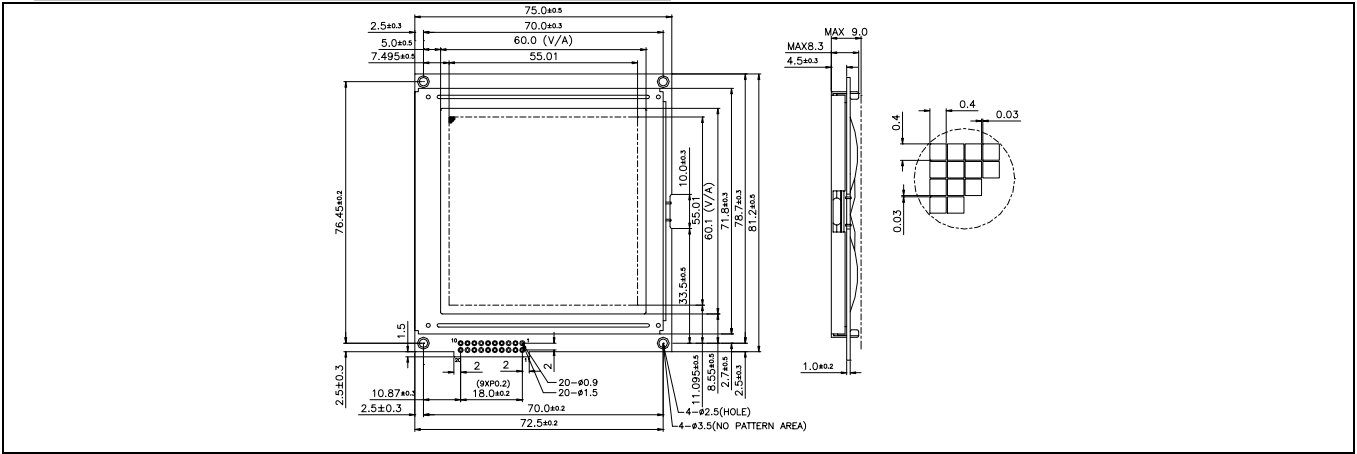

2. MECHANICAL DATA

ITEM	SPECIFICATION	UNIT
Module Size (W×H×T)	75.0×81.2×8.1	mm
Viewing Area (W×H)	60.0×60.1	mm
Number of Dots (W×H)	128×128	dots
Dot Pitch (W×H)	0.43×0.43	mm
Dot Size (W×H)	0.4×0.4	mm

3. ELECTRICAL CHARACTERISTICS (Ta=25 °C)

ITEM	SYMBOL	CONDITION	SPEC. VALUE			UNIT
			MIN.	TYP.	MAX.	
Supply Voltage (Logic)	V _{DD} - V _{SS}		4.5	5.0	5.5	V
Supply Current (Logic)	I _{DD}	V _{DD} =5V	-	3.0	4.5	mA
Input Voltage	"HIGH"	V _{IH}	0.7V _{DD}	-	V _{DD}	V
	"LOW"	V _{IL}	-	0	0.3V _{DD}	V
Output Voltage	"HIGH"	V _{OH}	-I _{OH} =0.205mA	2.4	-	V
	"LOW"	V _{OL}	I _{OL} =1.6mA	-	0.4	V
LCD Operating Voltage	V _{DD} - V _{EE}	V _{DD} =5V, Ta=25 °C	-	17.8	-	V
Supply Voltage LCD Drive	I _{EE}		-	9.8	-	mA

4. PIN CONFIGURATION

PIN	SYMBOL	SIGNAL DESCRIPTION	PIN	SYMBOL	SIGNAL DESCRIPTION
1	V _{SS}	GND (0V)	11	DB ₄	Data Bit 4
2	V _{DD}	Power Supply	12	DB ₅	Data Bit 5
3	V _{EE}	Supply Voltage LCD Driving	13	DB ₆	Data Bit 6
4	RS	Register Select Low = Instruction, High = Data	14	DB ₇	Data Bit 7
5	R/W	H : Read (Module→MPU), L : Write (MPU→Module)	15	CS1	Chip Select Signal for IC1
6	E	Enable	16	CS2	Chip Select Signal for IC2
7	DB ₀	Data Bit 0	17	/RES	Reset Signal
8	DB ₁	Data Bit 1	18	V _{out}	Power supply Voltage for LCD
9	DB ₂	Data Bit 2	19	EL	EL Power
10	DB ₃	Data Bit 3	20	EL	EL Power

5. BLOCK DIAGRAM

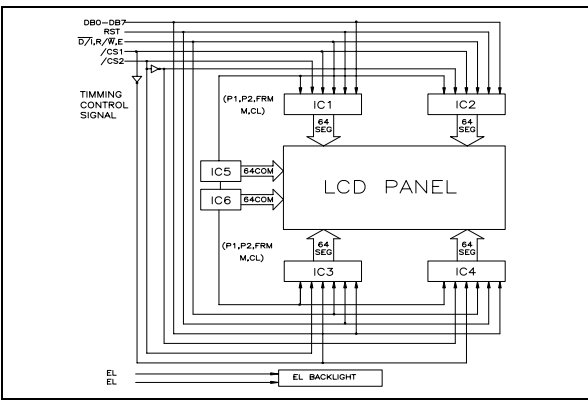

6. BACKLIGHTING CHARACTERISTICS (Ta=25 °C)

EL

ITEM	SYMBOL	CONDITION	MIN	TYP	MAX	UNIT
Applied Voltage	V _{EL}		-	100	150	V
Applied Frequency	F _{EL}		-	400	-	Hz
Power Consumption	P _{EL}	V _a =100Vrms	-	5.27	7.47	mW
		F _{EL} =400Hz	45	55	-	cd/m ²