

## ■ General Description

The AME8500 family allows the user to customize the CPU reset function without any external components. The user has a large choice of reset voltage thresholds, reset time intervals, and output driver configurations, all of which are preset at the factory. Each wafer is trimmed to the customer's specifications.

These circuits monitor the power supply voltage of  $\mu$ P based systems. When the power supply voltage drops below the voltage threshold a reset is asserted immediately (within an interval  $T_{D1}$ ). The reset remains asserted after the supply voltage rises above the voltage threshold for a time interval,  $T_{D2}$ . The reset output may be either active high (RESET) or active low (RESETB). The reset output may be configured as either push/pull or open drain. The state of the reset output is guaranteed to be correct for supply voltages greater than 1V.

Space saving SOT23/TSOT-23 packages and micropower quiescent current ( $<3.0\mu\text{A}$ ) make this family a natural for portable battery powered equipment.

## ■ Features

- Small Packages: SOT-23/TSOT-23, SOT-89
- Tight Voltage Threshold Tolerance  $\pm 1.50\%$
- Wide Temperature Range  $-40^\circ\text{C}$  to  $+85^\circ\text{C}$
- Low Quiescent Current  $< 3.0\mu\text{A}$
- All AME's Lead Free Products Meet RoHS standards

## ■ Applications

- Portable Electronics
- Power Supplies
- Computer Peripherals
- Data Acquisition Systems
- Applications using CPUs
- Consumer Electronics

## ■ Typical Operating Circuit

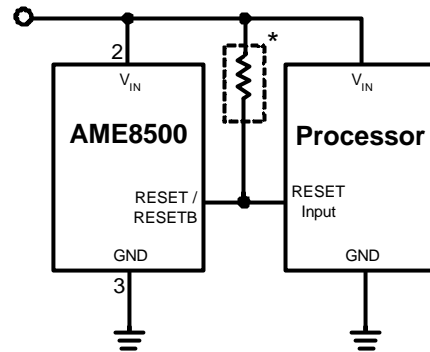

Note: \* External pull-up resistor is required if open-drain output is used. 10 k $\Omega$  is recommended.

## ■ Block Diagram

AME8500 with Push-Pull RESETB

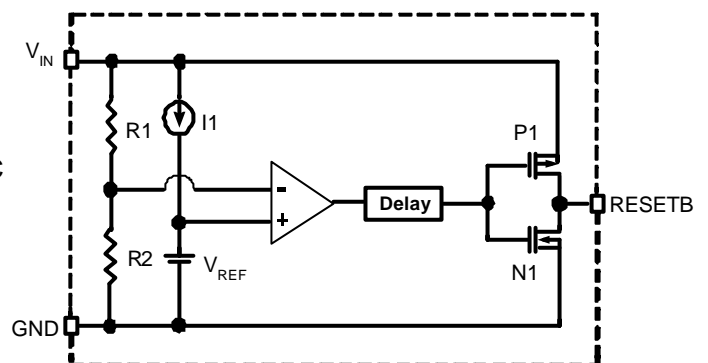

AME8500 with Push-Pull RESET

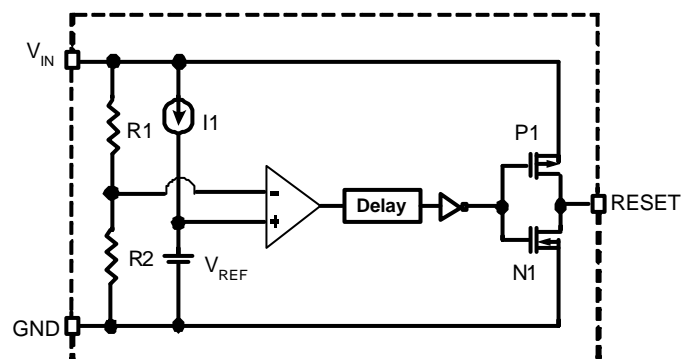

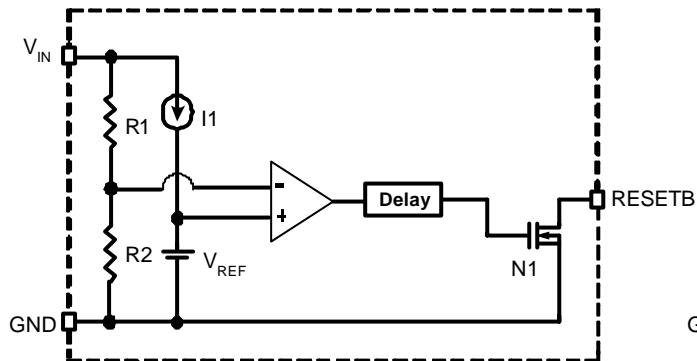
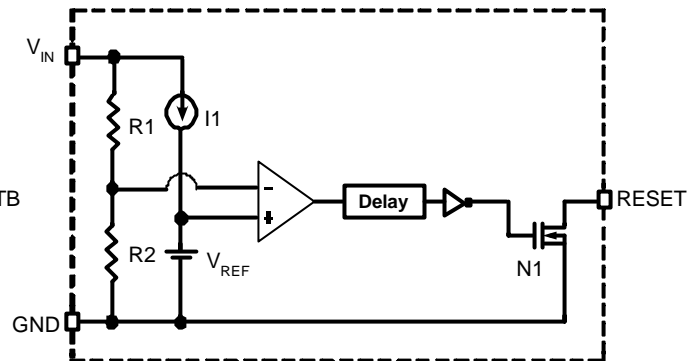
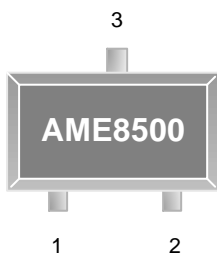
**■ Block Diagram (contd.)**
**AME8500 with Open-Drain RESETB**

**AME8500 with Open-Drain RESET**

**■ Pin Configuration**
**SOT-23/TSOT-23  
Top View**

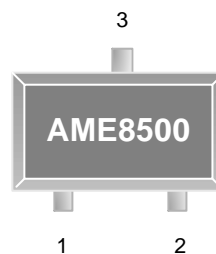
**AME8500AEET**

1. GND
2. Reset/ResetB
3. IN

\* Die Attach:  
Non-Conductive Epoxy

**SOT-23/TSOT-23  
Top View**

**AME8500BEET**

1. Reset/ResetB
2. GND
3. IN

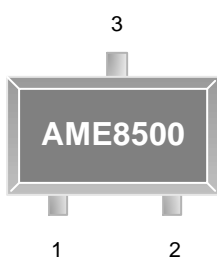
\* Die Attach:  
Non-Conductive Epoxy

**SOT-23/TSOT-23  
Top View**

**AME8500CEET**

1. Reset/ResetB
2. IN
3. GND

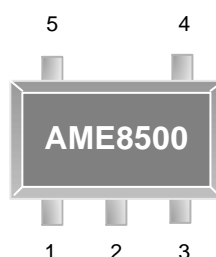
\* Die Attach:  
Conductive Epoxy

**SOT-25/TSOT-25  
Top View**

**AME8500BEEV**

1. Reset/ResetB
2. IN
3. GND
4. N/C
5. N/C

\* Die Attach:  
Non-Conductive Epoxy

**■ Pin Configuration (contd.)**

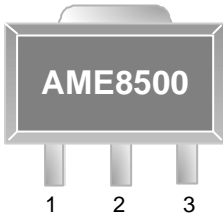
SOT-89  
Top View



- AME8500AEFT**
1. GND
  2. IN(TAB)
  3. Reset/ResetB

\* **Die Attach:**  
**Non-Conductive Epoxy**

SOT-89  
Top View

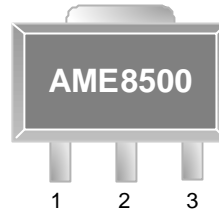

- AME8500BEFT**
1. Reset/ResetB
  2. IN(TAB)
  3. GND

\* **Die Attach:**  
**Non-Conductive Epoxy**

SOT-89  
Top View

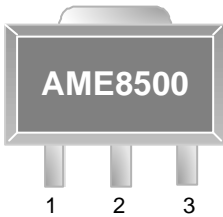

- AME8500CEFT**
1. IN
  2. GND(TAB)
  3. Reset/ResetB

\* **Die Attach:**  
**Conductive Epoxy**

**■ Pin Description**

Pin Name	Pin Description
GND	Ground
RESETB/RESET	This pin can be ordered as RESET or RESETB. RESET is active high. RESETB is active low. It is also available with an open drain or pushpull output.
IN	Positive power supply. A reset is asserted after this voltage drops below a predetermined level. After $V_{IN}$ rises above that level the reset output remains asserted until the end of the reset timeout period.

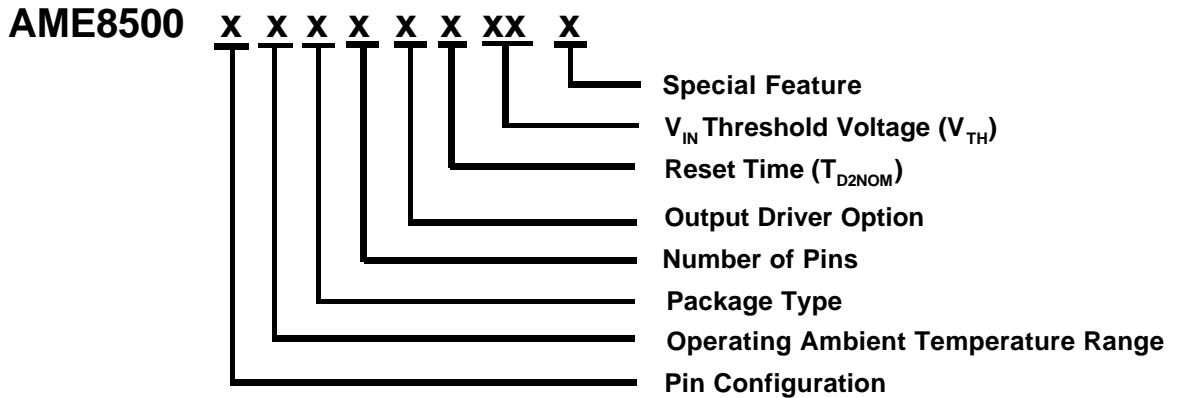
**Ordering Information**

Pin Configuration	Operating Ambient Temperature Range	Package Type	Number of Pins	Output Driver Option Characteristic of RESET or RESETB Pin	Reset Time (T <sub>D2NOM</sub> )	V <sub>IN</sub> Threshold Voltage (V <sub>TH</sub> )	Special Feature
<b>A</b> (SOT-23) 1. GND (TSOT-23) 2. Reset/ ResetB 3. IN  <b>B</b> (SOT-23) 1. Reset/ ResetB (TSOT-23) 2. GND 3. IN  <b>C</b> (SOT-23) 1. Reset/ ResetB (TSOT-23) 2. IN 3. GND  <b>A</b> (SOT-89) 1. GND 2. IN 3. Reset/ ResetB  <b>B</b> (SOT-89) 1. Reset/ ResetB 2. IN 3. GND  <b>C</b> (SOT-89) 1. IN 2. GND 3. Reset/ ResetB  <b>B</b> (SOT-25) 1. Reset/ ResetB (TSOT-25) 2. IN 3. GND 4. N/C 5. N/C	E -40°C to +85°C	E: SOT-2X F: SOT-89	T: 3 V: 5	A: RESETB /PP B: RESETB /OD C: RESET/ PP D: RESET/ OD  (RESET = Active High) (RESETB = Active Low) (PP = Push pull out) (OD = Open drain output )	A: 1.5 ms E: 150 ms F: 210 ms	16:V <sub>TH</sub> = 1.60V 18:V <sub>TH</sub> = 1.80V 19:V <sub>TH</sub> = 1.90V 20:V <sub>TH</sub> = 2.00V 21:V <sub>TH</sub> = 2.10V 22:V <sub>TH</sub> = 2.20V 23:V <sub>TH</sub> = 2.32V 24:V <sub>TH</sub> = 2.40V 25:V <sub>TH</sub> = 2.50V 26:V <sub>TH</sub> = 2.63V 27:V <sub>TH</sub> = 2.70V 28:V <sub>TH</sub> = 2.80V 29:V <sub>TH</sub> = 2.93V 30:V <sub>TH</sub> = 3.00V 31:V <sub>TH</sub> = 3.08V 35:V <sub>TH</sub> = 3.50V 40:V <sub>TH</sub> = 4.00V 42:V <sub>TH</sub> = 4.20V 44:V <sub>TH</sub> = 4.38V 45:V <sub>TH</sub> = 4.50V 46:V <sub>TH</sub> = 4.63V	L: Low profile Y: Lead free & Low profile Z: Lead free



# AME8500

# mProcessor Supervisory

## ■ Ordering Information

Part Number	Marking*	Detect Voltage	Package	Operating Ambient Temperature Range
AME8500AEETAA16	BCHww	1.60V	SOT-23	- 40°C to +85°C
AME8500AEETAA16L	BCHww	1.60V	TSOT-23	- 40°C to +85°C
AME8500AEETAA16Z	BCHww	1.60V	SOT-23	- 40°C to +85°C
AME8500AEETAA16Y	BCHww	1.60V	TSOT-23	- 40°C to +85°C
AME8500AEETAA21	ASVww	2.10V	SOT-23	- 40°C to +85°C
AME8500AEETAA21L	ASVww	2.10V	TSOT-23	- 40°C to +85°C
AME8500AEETAA21Z	ASVww	2.10V	SOT-23	- 40°C to +85°C
AME8500AEETAA21Y	ASVww	2.10V	TSOT-23	- 40°C to +85°C
AME8500AEETAE20	AUAww	2.00V	SOT-23	- 40°C to +85°C
AME8500AEETAE20L	AUAww	2.00V	TSOT-23	- 40°C to +85°C
AME8500AEETAE20Z	AUAww	2.00V	SOT-23	- 40°C to +85°C
AME8500AEETAE20Y	AUAww	2.00V	TSOT-23	- 40°C to +85°C
AME8500AEETAE21	AVGww	2.10V	SOT-23	- 40°C to +85°C
AME8500AEETAE21L	AVGww	2.10V	TSOT-23	- 40°C to +85°C
AME8500AEETAE21Z	AVGww	2.10V	SOT-23	- 40°C to +85°C
AME8500AEETAE21Y	AVGww	2.10V	TSOT-23	- 40°C to +85°C
AME8500AEETAE23	BAUww	2.32V	SOT-23	- 40°C to +85°C
AME8500AEETAE23L	BAUww	2.32V	TSOT-23	- 40°C to +85°C
AME8500AEETAE23Z	BAUww	2.32V	SOT-23	- 40°C to +85°C
AME8500AEETAE23Y	BAUww	2.32V	TSOT-23	- 40°C to +85°C
AME8500AEETAE26	ASJww	2.63V	SOT-23	- 40°C to +85°C
AME8500AEETAE26L	ASJww	2.63V	TSOT-23	- 40°C to +85°C
AME8500AEETAE26Z	ASJww	2.63V	SOT-23	- 40°C to +85°C
AME8500AEETAE26Y	ASJww	2.63V	TSOT-23	- 40°C to +85°C
AME8500AEETAE29	ALYww	2.93V	SOT-23	- 40°C to +85°C
AME8500AEETAE29L	ALYww	2.93V	TSOT-23	- 40°C to +85°C
AME8500AEETAE29Z	ALYww	2.93V	SOT-23	- 40°C to +85°C
AME8500AEETAE29Y	ALYww	2.93V	TSOT-23	- 40°C to +85°C

Note: ww represents the date code and pls refer to the Date Code Rule before the Package Dimension.

\* A line on top of the first letter represents lead free plating such as BCH

Pls consult AME sales office or authorized Rep./Distributor for the availability of output voltage or package type.

**■ Ordering Information (contd.)**

Part Number	Marking*	Detect Voltage	Package	Operating Ambient Temperature Range
AME8500AEETAE31	AUBww	3.08V	SOT-23	- 40°C to +85°C
AME8500AEETAE31L	AUBww	3.08V	TSOT-23	- 40°C to +85°C
AME8500AEETAE31Z	AUBww	3.08V	SOT-23	- 40°C to +85°C
AME8500AEETAE31Y	AUBww	3.08V	TSOT-23	- 40°C to +85°C
AME8500AEETAE46	ATSww	4.63V	SOT-23	- 40°C to +85°C
AME8500AEETAE46L	ATSww	4.63V	TSOT-23	- 40°C to +85°C
AME8500AEETAE46Z	ATSww	4.63V	SOT-23	- 40°C to +85°C
AME8500AEETAE46Y	ATSww	4.63V	TSOT-23	- 40°C to +85°C
AME8500AEETAF16	ATEww	1.60V	SOT-23	- 40°C to +85°C
AME8500AEETAF16L	ATEww	1.60V	TSOT-23	- 40°C to +85°C
AME8500AEETAF16Z	ATEww	1.60V	SOT-23	- 40°C to +85°C
AME8500AEETAF16Y	ATEww	1.60V	TSOT-23	- 40°C to +85°C
AME8500AEETAF20	BDTww	2.00V	SOT-23	- 40°C to +85°C
AME8500AEETAF20L	BDTww	2.00V	TSOT-23	- 40°C to +85°C
AME8500AEETAF20Z	BDTww	2.00V	SOT-23	- 40°C to +85°C
AME8500AEETAF20Y	BDTww	2.00V	TSOT-23	- 40°C to +85°C
AME8500AEETAF21	ASKww	2.10V	SOT-23	- 40°C to +85°C
AME8500AEETAF21L	ASKww	2.10V	TSOT-23	- 40°C to +85°C
AME8500AEETAF21Z	ASKww	2.10V	SOT-23	- 40°C to +85°C
AME8500AEETAF21Y	ASKww	2.10V	TSOT-23	- 40°C to +85°C
AME8500AEETAF23	ATTww	2.32V	SOT-23	- 40°C to +85°C
AME8500AEETAF23L	ATTww	2.32V	TSOT-23	- 40°C to +85°C
AME8500AEETAF23Z	ATTww	2.32V	SOT-23	- 40°C to +85°C
AME8500AEETAF23Y	ATTww	2.32V	TSOT-23	- 40°C to +85°C
AME8500AEETAF25	AUYww	2.50V	SOT-23	- 40°C to +85°C
AME8500AEETAF25L	AUYww	2.50V	TSOT-23	- 40°C to +85°C
AME8500AEETAF25Z	AUYww	2.50V	SOT-23	- 40°C to +85°C
AME8500AEETAF25Y	AUYww	2.50V	TSOT-23	- 40°C to +85°C

**■ Ordering Information (contd.)**

Part Number	Marking*	Detect Voltage	Package	Operating Ambient Temperature Range
AME8500AEETAF26	AMPww	2.63V	SOT-23	- 40°C to +85°C
AME8500AEETAF26L	AMPww	2.63V	TSOT-23	- 40°C to +85°C
AME8500AEETAF26Z	AMPww	2.63V	SOT-23	- 40°C to +85°C
AME8500AEETAF26Y	AMPww	2.63V	TSOT-23	- 40°C to +85°C
AME8500AEETAF27	ATRww	2.70V	SOT-23	- 40°C to +85°C
AME8500AEETAF27L	ATRww	2.70V	TSOT-23	- 40°C to +85°C
AME8500AEETAF27Z	ATRww	2.70V	SOT-23	- 40°C to +85°C
AME8500AEETAF27Y	ATRww	2.70V	TSOT-23	- 40°C to +85°C
AME8500AEETAF29	AMOww	2.93V	SOT-23	- 40°C to +85°C
AME8500AEETAF29L	AMOww	2.93V	TSOT-23	- 40°C to +85°C
AME8500AEETAF29Z	AMOww	2.93V	SOT-23	- 40°C to +85°C
AME8500AEETAF29Y	AMOww	2.93V	TSOT-23	- 40°C to +85°C
AME8500AEETAF30	ASGww	3.00V	SOT-23	- 40°C to +85°C
AME8500AEETAF30L	ASGww	3.00V	TSOT-23	- 40°C to +85°C
AME8500AEETAF30Z	ASGww	3.00V	SOT-23	- 40°C to +85°C
AME8500AEETAF30Y	ASGww	3.00V	TSOT-23	- 40°C to +85°C
AME8500AEETAF31	ASAww	3.08V	SOT-23	- 40°C to +85°C
AME8500AEETAF31L	ASAww	3.08V	TSOT-23	- 40°C to +85°C
AME8500AEETAF31Z	ASAww	3.08V	SOT-23	- 40°C to +85°C
AME8500AEETAF31Y	ASAww	3.08V	TSOT-23	- 40°C to +85°C
AME8500AEETAF40	ASBww	4.00V	SOT-23	- 40°C to +85°C
AME8500AEETAF40L	ASBww	4.00V	TSOT-23	- 40°C to +85°C
AME8500AEETAF40Z	ASBww	4.00V	SOT-23	- 40°C to +85°C
AME8500AEETAF40Y	ASBww	4.00V	TSOT-23	- 40°C to +85°C
AME8500AEETAF44	ARNww	4.38V	SOT-23	- 40°C to +85°C
AME8500AEETAF44L	ARNww	4.38V	TSOT-23	- 40°C to +85°C
AME8500AEETAF44Z	ARNww	4.38V	SOT-23	- 40°C to +85°C
AME8500AEETAF44Y	ARNww	4.38V	TSOT-23	- 40°C to +85°C

**■ Ordering Information (contd.)**

Part Number	Marking*	Detect Voltage	Package	Operating Ambient Temperature Range
AME8500AEETAF46	ARKww	4.63V	SOT-23	- 40°C to +85°C
AME8500AEETAF46L	ARKww	4.63V	TSOT-23	- 40°C to +85°C
AME8500AEETAF46Z	ARKww	4.63V	SOT-23	- 40°C to +85°C
AME8500AEETAF46Y	ARKww	4.63V	TSOT-23	- 40°C to +85°C
AME8500AEETBA24	ARRww	2.40V	SOT-23	- 40°C to +85°C
AME8500AEETBA24L	ARRww	2.40V	TSOT-23	- 40°C to +85°C
AME8500AEETBA24Z	ARRww	2.40V	SOT-23	- 40°C to +85°C
AME8500AEETBA24Y	ARRww	2.40V	TSOT-23	- 40°C to +85°C
AME8500AEETBA30	ARQww	3.00V	SOT-23	- 40°C to +85°C
AME8500AEETBA30L	ARQww	3.00V	TSOT-23	- 40°C to +85°C
AME8500AEETBA30Z	ARQww	3.00V	SOT-23	- 40°C to +85°C
AME8500AEETBA30Y	ARQww	3.00V	TSOT-23	- 40°C to +85°C
AME8500AEETBE18	BALww	1.80V	SOT-23	- 40°C to +85°C
AME8500AEETBE18L	BALww	1.80V	TSOT-23	- 40°C to +85°C
AME8500AEETBE18Z	BALww	1.80V	SOT-23	- 40°C to +85°C
AME8500AEETBE18Y	BALww	1.80V	TSOT-23	- 40°C to +85°C
AME8500AEETBE20	AWXww	2.00V	SOT-23	- 40°C to +85°C
AME8500AEETBE20L	AWXww	2.00V	TSOT-23	- 40°C to +85°C
AME8500AEETBE20Z	AWXww	2.00V	SOT-23	- 40°C to +85°C
AME8500AEETBE20Y	AWXww	2.00V	TSOT-23	- 40°C to +85°C
AME8500AEETBF16	BCGww	1.60V	SOT-23	- 40°C to +85°C
AME8500AEETBF16L	BCGww	1.60V	TSOT-23	- 40°C to +85°C
AME8500AEETBF16Z	BCGww	1.60V	SOT-23	- 40°C to +85°C
AME8500AEETBF16Y	BCGww	1.60V	TSOT-23	- 40°C to +85°C
AME8500AEETBF31	AUTww	3.08V	SOT-23	- 40°C to +85°C
AME8500AEETBF31L	AUTww	3.08V	TSOT-23	- 40°C to +85°C
AME8500AEETBF31Z	AUTww	3.08V	SOT-23	- 40°C to +85°C
AME8500AEETBF31Y	AUTww	3.08V	TSOT-23	- 40°C to +85°C



**■ Ordering Information (contd.)**

Part Number	Marking*	Detect Voltage	Package	Operating Ambient Temperature Range
AME8500AEETBF44	AYRww	4.38V	SOT-23	- 40°C to +85°C
AME8500AEETBF44L	AYRww	4.38V	TSOT-23	- 40°C to +85°C
AME8500AEETBF44Z	AYRww	4.38V	SOT-23	- 40°C to +85°C
AME8500AEETBF44Y	AYRww	4.38V	TSOT-23	- 40°C to +85°C
AME8500AEETBF46	AUUww	4.63V	SOT-23	- 40°C to +85°C
AME8500AEETBF46L	AUUww	4.63V	TSOT-23	- 40°C to +85°C
AME8500AEETBF46Z	AUUww	4.63V	SOT-23	- 40°C to +85°C
AME8500AEETBF46Y	AUUww	4.63V	TSOT-23	- 40°C to +85°C
AME8500AEETCA21	ASWww	2.10V	SOT-23	- 40°C to +85°C
AME8500AEETCA21L	ASWww	2.10V	TSOT-23	- 40°C to +85°C
AME8500AEETCA21Z	ASWww	2.10V	SOT-23	- 40°C to +85°C
AME8500AEETCA21Y	ASWww	2.10V	TSOT-23	- 40°C to +85°C
AME8500AEETCA27	AVBww	2.70V	SOT-23	- 40°C to +85°C
AME8500AEETCA27L	AVBww	2.70V	TSOT-23	- 40°C to +85°C
AME8500AEETCA27Z	AVBww	2.70V	SOT-23	- 40°C to +85°C
AME8500AEETCA27Y	AVBww	2.70V	TSOT-23	- 40°C to +85°C
AME8500AEETCA46	AVCww	4.63V	SOT-23	- 40°C to +85°C
AME8500AEETCA46L	AVCww	4.63V	TSOT-23	- 40°C to +85°C
AME8500AEETCA46Z	AVCww	4.63V	SOT-23	- 40°C to +85°C
AME8500AEETCA46Y	AVCww	4.63V	TSOT-23	- 40°C to +85°C
AME8500AEETCF21	ATYww	2.10V	SOT-23	- 40°C to +85°C
AME8500AEETCF21L	ATYww	2.10V	TSOT-23	- 40°C to +85°C
AME8500AEETCF21Z	ATYww	2.10V	SOT-23	- 40°C to +85°C
AME8500AEETCF21Y	ATYww	2.10V	TSOT-23	- 40°C to +85°C
AME8500AEETCF26	AZMww	2.63V	SOT-23	- 40°C to +85°C
AME8500AEETCF26L	AZMww	2.63V	TSOT-23	- 40°C to +85°C
AME8500AEETCF26Z	AZMww	2.63V	SOT-23	- 40°C to +85°C
AME8500AEETCF26Y	AZMww	2.63V	TSOT-23	- 40°C to +85°C

**■ Ordering Information (contd.)**

Part Number	Marking*	Detect Voltage	Package	Operating Ambient Temperature Range
AME8500AEETCF29	ALVww	2.93V	SOT-23	- 40°C to +85°C
AME8500AEETCF29L	ALVww	2.93V	TSOT-23	- 40°C to +85°C
AME8500AEETCF29Z	ALVww	2.93V	SOT-23	- 40°C to +85°C
AME8500AEETCF29Y	ALVww	2.93V	TSOT-23	- 40°C to +85°C
AME8500AEETCF31	ASUww	3.08V	SOT-23	- 40°C to +85°C
AME8500AEETCF31L	ASUww	3.08V	TSOT-23	- 40°C to +85°C
AME8500AEETCF31Z	ASUww	3.08V	SOT-23	- 40°C to +85°C
AME8500AEETCF31Y	ASUww	3.08V	TSOT-23	- 40°C to +85°C
AME8500AEETCF46	ARJww	4.63V	SOT-23	- 40°C to +85°C
AME8500AEETCF46L	ARJww	4.63V	TSOT-23	- 40°C to +85°C
AME8500AEETCF46Z	ARJww	4.63V	SOT-23	- 40°C to +85°C
AME8500AEETCF46Y	ARJww	4.63V	TSOT-23	- 40°C to +85°C
AME8500AEETDE40	BCSww	4.00V	SOT-23	- 40°C to +85°C
AME8500AEETDE40L	BCSww	4.00V	TSOT-23	- 40°C to +85°C
AME8500AEETDE40Z	BCSww	4.00V	SOT-23	- 40°C to +85°C
AME8500AEETDE40Y	BCSww	4.00V	TSOT-23	- 40°C to +85°C
AME8500AEETDF26	ALUww	2.63V	SOT-23	- 40°C to +85°C
AME8500AEETDF26L	ALUww	2.63V	TSOT-23	- 40°C to +85°C
AME8500AEETDF26Z	ALUww	2.63V	SOT-23	- 40°C to +85°C
AME8500AEETDF26Y	ALUww	2.63V	TSOT-23	- 40°C to +85°C
AME8500AEETDF27	BCTww	2.70V	SOT-23	- 40°C to +85°C
AME8500AEETDF27L	BCTww	2.70V	TSOT-23	- 40°C to +85°C
AME8500AEETDF27Z	BCTww	2.70V	SOT-23	- 40°C to +85°C
AME8500AEETDF27Y	BCTww	2.70V	TSOT-23	- 40°C to +85°C
AME8500AEETDF28	BCUww	2.80V	SOT-23	- 40°C to +85°C
AME8500AEETDF28L	BCUww	2.80V	TSOT-23	- 40°C to +85°C
AME8500AEETDF28Z	BCUww	2.80V	SOT-23	- 40°C to +85°C
AME8500AEETDF28Y	BCUww	2.80V	TSOT-23	- 40°C to +85°C

**■ Ordering Information (contd.)**

Part Number	Marking*	Detect Voltage	Package	Operating Ambient Temperature Range
AME8500AEETDF30	BCVww	3.00V	SOT-23	- 40°C to +85°C
AME8500AEETDF30L	BCVww	3.00V	TSOT-23	- 40°C to +85°C
AME8500AEETDF30Z	BCVww	3.00V	SOT-23	- 40°C to +85°C
AME8500AEETDF30Y	BCVww	3.00V	TSOT-23	- 40°C to +85°C
AME8500AEETDF46	ARlww	4.63V	SOT-23	- 40°C to +85°C
AME8500AEETDF46L	ARlww	4.63V	TSOT-23	- 40°C to +85°C
AME8500AEETDF46Z	ARlww	4.63V	SOT-23	- 40°C to +85°C
AME8500AEETDF46Y	ARlww	4.63V	TSOT-23	- 40°C to +85°C
AME8500AEFTAA21	A8500A AA21ww	2.10V	SOT-89	- 40°C to +85°C
AME8500AEFTAA21Z	A8500A AA21ww	2.10V	SOT-89	- 40°C to +85°C
AME8500AEFTAF27	A8500A AF27ww	2.70V	SOT-89	- 40°C to +85°C
AME8500AEFTAF27Z	A8500A AF27ww	2.70V	SOT-89	- 40°C to +85°C
AME8500AEFTCA21	A8500A CA21ww	2.10V	SOT-89	- 40°C to +85°C
AME8500AEFTCA21Z	A8500A CA21ww	2.10V	SOT-89	- 40°C to +85°C
AME8500AEFTDA21	A8500A DA21ww	2.10V	SOT-89	- 40°C to +85°C
AME8500AEFTDA21Z	A8500A DA21ww	2.10V	SOT-89	- 40°C to +85°C
AME8500BEETAA21	ARTww	2.10V	SOT-23	- 40°C to +85°C
AME8500BEETAA21L	ARTww	2.10V	TSOT-23	- 40°C to +85°C
AME8500BEETAA21Z	ARTww	2.10V	SOT-23	- 40°C to +85°C
AME8500BEETAA21Y	ARTww	2.10V	TSOT-23	- 40°C to +85°C
AME8500BEETAA27	ARMww	2.70V	SOT-23	- 40°C to +85°C
AME8500BEETAA27L	ARMww	2.70V	TSOT-23	- 40°C to +85°C
AME8500BEETAA27Z	ARMww	2.70V	SOT-23	- 40°C to +85°C
AME8500BEETAA27Y	ARMww	2.70V	TSOT-23	- 40°C to +85°C

**■ Ordering Information (contd.)**

Part Number	Marking*	Detect Voltage	Package	Operating Ambient Temperature Range
AME8500BEETAA28	ASRww	2.80V	SOT-23	- 40°C to +85°C
AME8500BEETAA28L	ASRww	2.80V	TSOT-23	- 40°C to +85°C
AME8500BEETAA28Z	ASRww	2.80V	SOT-23	- 40°C to +85°C
AME8500BEETAA28Y	ASRww	2.80V	TSOT-23	- 40°C to +85°C
AME8500BEETAA29	ARZww	2.93V	SOT-23	- 40°C to +85°C
AME8500BEETAA29L	ARZww	2.93V	TSOT-23	- 40°C to +85°C
AME8500BEETAA29Z	ARZww	2.93V	SOT-23	- 40°C to +85°C
AME8500BEETAA29Y	ARZww	2.93V	TSOT-23	- 40°C to +85°C
AME8500BEETAA30	ASCww	3.00V	SOT-23	- 40°C to +85°C
AME8500BEETAA30L	ASCww	3.00V	TSOT-23	- 40°C to +85°C
AME8500BEETAA30Z	ASCww	3.00V	SOT-23	- 40°C to +85°C
AME8500BEETAA30Y	ASCww	3.00V	TSOT-23	- 40°C to +85°C
AME8500BEETAA45	ATPww	4.50V	SOT-23	- 40°C to +85°C
AME8500BEETAA45L	ATPww	4.50V	TSOT-23	- 40°C to +85°C
AME8500BEETAA45Z	ATPww	4.50V	SOT-23	- 40°C to +85°C
AME8500BEETAA45Y	ATPww	4.50V	TSOT-23	- 40°C to +85°C
AME8500BEETAF27	AUCww	2.70V	SOT-23	- 40°C to +85°C
AME8500BEETAF27L	AUCww	2.70V	TSOT-23	- 40°C to +85°C
AME8500BEETAF27Z	AUCww	2.70V	SOT-23	- 40°C to +85°C
AME8500BEETAF27Y	AUCww	2.70V	TSOT-23	- 40°C to +85°C
AME8500BEETAF29	AUVww	2.93V	SOT-23	- 40°C to +85°C
AME8500BEETAF29L	AUVww	2.93V	TSOT-23	- 40°C to +85°C
AME8500BEETAF29Z	AUVww	2.93V	SOT-23	- 40°C to +85°C
AME8500BEETAF29Y	AUVww	2.93V	TSOT-23	- 40°C to +85°C
AME8500BEETAF31	ATOww	3.08V	SOT-23	- 40°C to +85°C
AME8500BEETAF31L	ATOww	3.08V	TSOT-23	- 40°C to +85°C
AME8500BEETAF31Z	ATOww	3.08V	SOT-23	- 40°C to +85°C
AME8500BEETAF31Y	ATOww	3.08V	TSOT-23	- 40°C to +85°C

**■ Ordering Information (contd.)**

Part Number	Marking*	Detect Voltage	Package	Operating Ambient Temperature Range
AME8500BEETAF40	ATQww	4.00V	SOT-23	- 40°C to +85°C
AME8500BEETAF40L	ATQww	4.00V	TSOT-23	- 40°C to +85°C
AME8500BEETAF40Z	ATQww	4.00V	SOT-23	- 40°C to +85°C
AME8500BEETAF40Y	ATQww	4.00V	TSOT-23	- 40°C to +85°C
AME8500BEETBA21	AUWww	2.10V	SOT-23	- 40°C to +85°C
AME8500BEETBA21L	AUWww	2.10V	TSOT-23	- 40°C to +85°C
AME8500BEETBA21Z	AUWww	2.10V	SOT-23	- 40°C to +85°C
AME8500BEETBA21Y	AUWww	2.10V	TSOT-23	- 40°C to +85°C
AME8500BEETBA22	AVDww	2.20V	SOT-23	- 40°C to +85°C
AME8500BEETBA22L	AVDww	2.20V	TSOT-23	- 40°C to +85°C
AME8500BEETBA22Z	AVDww	2.20V	SOT-23	- 40°C to +85°C
AME8500BEETBA22Y	AVDww	2.20V	TSOT-23	- 40°C to +85°C
AME8500BEETBA24	AUXww	2.40V	SOT-23	- 40°C to +85°C
AME8500BEETBA24L	AUXww	2.40V	TSOT-23	- 40°C to +85°C
AME8500BEETBA24Z	AUXww	2.40V	SOT-23	- 40°C to +85°C
AME8500BEETBA24Y	AUXww	2.40V	TSOT-23	- 40°C to +85°C
AME8500BEETBA25	AVQww	2.50V	SOT-23	- 40°C to +85°C
AME8500BEETBA25L	AVQww	2.50V	TSOT-23	- 40°C to +85°C
AME8500BEETBA25Z	AVQww	2.50V	SOT-23	- 40°C to +85°C
AME8500BEETBA25Y	AVQww	2.50V	TSOT-23	- 40°C to +85°C
AME8500BEETBA27	ASQww	2.70V	SOT-23	- 40°C to +85°C
AME8500BEETBA27L	ASQww	2.70V	TSOT-23	- 40°C to +85°C
AME8500BEETBA27Z	ASQww	2.70V	SOT-23	- 40°C to +85°C
AME8500BEETBA27Y	ASQww	2.70V	TSOT-23	- 40°C to +85°C
AME8500BEETBA28	ASSww	2.80V	SOT-23	- 40°C to +85°C
AME8500BEETBA28L	ASSww	2.80V	TSOT-23	- 40°C to +85°C
AME8500BEETBA28Z	ASSww	2.80V	SOT-23	- 40°C to +85°C
AME8500BEETBA28Y	ASSww	2.80V	TSOT-23	- 40°C to +85°C

**■ Ordering Information (contd.)**

Part Number	Marking*	Detect Voltage	Package	Operating Ambient Temperature Range
AME8500BEETBA29	ARLww	2.93V	SOT-23	- 40°C to +85°C
AME8500BEETBA29L	ARLww	2.93V	TSOT-23	- 40°C to +85°C
AME8500BEETBA29Z	ARLww	2.93V	SOT-23	- 40°C to +85°C
AME8500BEETBA29Y	ARLww	2.93V	TSOT-23	- 40°C to +85°C
AME8500BEETBA35	AZGww	3.50V	SOT-23	- 40°C to +85°C
AME8500BEETBA35L	AZGww	3.50V	TSOT-23	- 40°C to +85°C
AME8500BEETBA35Z	AZGww	3.50V	SOT-23	- 40°C to +85°C
AME8500BEETBA35Y	AZGww	3.50V	TSOT-23	- 40°C to +85°C
AME8500BEETBA42	ASlww	4.20V	SOT-23	- 40°C to +85°C
AME8500BEETBA42L	ASlww	4.20V	TSOT-23	- 40°C to +85°C
AME8500BEETBA42Z	ASlww	4.20V	SOT-23	- 40°C to +85°C
AME8500BEETBA42Y	ASlww	4.20V	TSOT-23	- 40°C to +85°C
AME8500BEETBE21	BBDww	2.10V	SOT-23	- 40°C to +85°C
AME8500BEETBE21L	BBDww	2.10V	TSOT-23	- 40°C to +85°C
AME8500BEETBE21Z	BBDww	2.10V	SOT-23	- 40°C to +85°C
AME8500BEETBE21Y	BBDww	2.10V	TSOT-23	- 40°C to +85°C
AME8500BEETBE42	BDUww	4.20V	SOT-23	- 40°C to +85°C
AME8500BEETBE42L	BDUww	4.20V	TSOT-23	- 40°C to +85°C
AME8500BEETBE42Z	BDUww	4.20V	SOT-23	- 40°C to +85°C
AME8500BEETBE42Y	BDUww	4.20V	TSOT-23	- 40°C to +85°C
AME8500BEETBF45	BDXww	4.50V	SOT-23	- 40°C to +85°C
AME8500BEETBF45L	BDXww	4.50V	TSOT-23	- 40°C to +85°C
AME8500BEETBF45Z	BDXww	4.50V	SOT-23	- 40°C to +85°C
AME8500BEETBF45Y	BDXww	4.50V	TSOT-23	- 40°C to +85°C
AMF8500BEFTBF21	BBEww	2.10V	SOT-89	- 40°C to +85°C
AMF8500BEFTBF21L	BBEww	2.10V	SOT-89	- 40°C to +85°C
AMF8500BEFTBF21Z	BBEww	2.10V	SOT-89	- 40°C to +85°C
AMF8500BEFTBF21Y	BBEww	2.10V	SOT-89	- 40°C to +85°C

**■ Ordering Information (contd.)**

Part Number	Marking*	Detect Voltage	Package	Operating Ambient Temperature Range
AME8500BEETCA21	ASXww	2.10V	SOT-23	- 40°C to +85°C
AME8500BEETCA21L	ASXww	2.10V	TSOT-23	- 40°C to +85°C
AME8500BEETCA21Z	ASXww	2.10V	SOT-23	- 40°C to +85°C
AME8500BEETCA21Y	ASXww	2.10V	TSOT-23	- 40°C to +85°C
AME8500BEEVAK27	AUFww	2.70V	SOT-25	- 40°C to +85°C
AME8500BEEVAK27L	AUFww	2.70V	TSOT-25	- 40°C to +85°C
AME8500BEEVAK27Z	AUFww	2.70V	SOT-25	- 40°C to +85°C
AME8500BEEVAK27Y	AUFww	2.70V	TSOT-25	- 40°C to +85°C
AME8500BEFTAA21	A8500B AA21ww	2.10V	SOT-89	- 40°C to +85°C
AME8500BEFTAA21Z	A8500B AA21ww	2.10V	SOT-89	- 40°C to +85°C
AME8500BEFTAA27	A8500B AA27ww	2.70V	SOT-89	- 40°C to +85°C
AME8500BEFTAA27Z	A8500B AA27ww	2.70V	SOT-89	- 40°C to +85°C
AME8500BEFTAF27	A8500B AF27ww	2.70V	SOT-89	- 40°C to +85°C
AME8500BEFTAF27Z	A8500B AF27ww	2.70V	SOT-89	- 40°C to +85°C
AME8500BEFTAF40	A8500B AF40ww	4.00V	SOT-89	- 40°C to +85°C
AME8500BEFTAF40Z	A8500B AF40ww	4.00V	SOT-89	- 40°C to +85°C
AME8500BEFTBA23	A8500B BA23ww	2.32V	SOT-89	- 40°C to +85°C
AME8500BEFTBA23Z	A8500B BA23ww	2.32V	SOT-89	- 40°C to +85°C
AME8500BEFTBA24	A8500B BA24ww	2.40V	SOT-89	- 40°C to +85°C
AME8500BEFTBA24Z	A8500B BA24ww	2.40V	SOT-89	- 40°C to +85°C
AME8500CEETAA21	ASYww	2.10V	SOT-23	- 40°C to +85°C
AME8500CEETAA21L	ASYww	2.10V	TSOT-23	- 40°C to +85°C
AME8500CEETAA21Z	ASYww	2.10V	SOT-23	- 40°C to +85°C
AME8500CEETAA21Y	ASYww	2.10V	TSOT-23	- 40°C to +85°C

**■ Ordering Information (contd.)**

Part Number	Marking*	Detect Voltage	Package	Operating Ambient Temperature Range
AME8500CEETAE24	BCRww	2.40V	SOT-23	- 40°C to +85°C
AME8500CEETAE24L	BCRww	2.40V	TSOT-23	- 40°C to +85°C
AME8500CEETAE24Z	BCRww	2.40V	SOT-23	- 40°C to +85°C
AME8500CEETAE24Y	BCRww	2.40V	TSOT-23	- 40°C to +85°C
AME8500CEETAE26	ASHww	2.63V	SOT-23	- 40°C to +85°C
AME8500CEETAE26L	ASHww	2.63V	TSOT-23	- 40°C to +85°C
AME8500CEETAE26Z	ASHww	2.63V	SOT-23	- 40°C to +85°C
AME8500CEETAE26Y	ASHww	2.63V	TSOT-23	- 40°C to +85°C
AME8500CEETAE28	BCQww	2.80V	SOT-23	- 40°C to +85°C
AME8500CEETAE28L	BCQww	2.80V	TSOT-23	- 40°C to +85°C
AME8500CEETAE28Z	BCQww	2.80V	SOT-23	- 40°C to +85°C
AME8500CEETAE28Y	BCQww	2.80V	TSOT-23	- 40°C to +85°C
AME8500CEETAE31	BDCww	3.08V	SOT-23	- 40°C to +85°C
AME8500CEETAE31L	BDCww	3.08V	TSOT-23	- 40°C to +85°C
AME8500CEETAE31Z	BDCww	3.08V	SOT-23	- 40°C to +85°C
AME8500CEETAE31Y	BDCww	3.08V	TSOT-23	- 40°C to +85°C
AME8500CEETAE40	BCPww	4.00V	SOT-23	- 40°C to +85°C
AME8500CEETAE40L	BCPww	4.00V	TSOT-23	- 40°C to +85°C
AME8500CEETAE40Z	BCPww	4.00V	SOT-23	- 40°C to +85°C
AME8500CEETAE40Y	BCPww	4.00V	TSOT-23	- 40°C to +85°C
AME8500CEETAE42	AUZww	4.20V	SOT-23	- 40°C to +85°C
AME8500CEETAE42L	AUZww	4.20V	TSOT-23	- 40°C to +85°C
AME8500CEETAE42Z	AUZww	4.20V	SOT-23	- 40°C to +85°C
AME8500CEETAE42Y	AUZww	4.20V	TSOT-23	- 40°C to +85°C
AME8500CEETAF29	ASLww	2.93V	SOT-23	- 40°C to +85°C
AME8500CEETAF29L	ASLww	2.93V	TSOT-23	- 40°C to +85°C
AME8500CEETAF29Z	ASLww	2.93V	SOT-23	- 40°C to +85°C
AME8500CEETAF29Y	ASLww	2.93V	TSOT-23	- 40°C to +85°C



**■ Ordering Information (contd.)**

Part Number	Marking*	Detect Voltage	Package	Operating Ambient Temperature Range
AME8500CEETBA26	AXLww	2.63V	SOT-23	- 40°C to +85°C
AME8500CEETBA26L	AXLww	2.63V	TSOT-23	- 40°C to +85°C
AME8500CEETBA26Z	AXLww	2.63V	SOT-23	- 40°C to +85°C
AME8500CEETBA26Y	AXLww	2.63V	TSOT-23	- 40°C to +85°C
AME8500CEETBE31	BAXww	3.08V	SOT-23	- 40°C to +85°C
AME8500CEETBE31L	BAXww	3.08V	TSOT-23	- 40°C to +85°C
AME8500CEETBE31Z	BAXww	3.08V	SOT-23	- 40°C to +85°C
AME8500CEETBE31Y	BAXww	3.08V	TSOT-23	- 40°C to +85°C
AME8500CEETBE42	AVAww	4.20V	SOT-23	- 40°C to +85°C
AME8500CEETBE42L	AVAww	4.20V	TSOT-23	- 40°C to +85°C
AME8500CEETBE42Z	AVAww	4.20V	SOT-23	- 40°C to +85°C
AME8500CEETBE42Y	AVAww	4.20V	TSOT-23	- 40°C to +85°C
AME8500CEETBF31	AVYww	3.08V	SOT-23	- 40°C to +85°C
AME8500CEETBF31L	AVYww	3.08V	TSOT-23	- 40°C to +85°C
AME8500CEETBF31Z	AVYww	3.08V	SOT-23	- 40°C to +85°C
AME8500CEETBF31Y	AVYww	3.08V	TSOT-23	- 40°C to +85°C
AME8500CEETBF29	BDOww	2.93V	SOT-23	- 40°C to +85°C
AME8500CEETBF29L	BDOww	2.93V	TSOT-23	- 40°C to +85°C
AME8500CEETBF29Z	BDOww	2.93V	SOT-23	- 40°C to +85°C
AME8500CEETBF29Y	BDOww	2.93V	TSOT-23	- 40°C to +85°C
AME8500CEETBF46	ARWww	4.63V	SOT-23	- 40°C to +85°C
AME8500CEETBF46L	ARWww	4.63V	TSOT-23	- 40°C to +85°C
AME8500CEETBF46Z	ARWww	4.63V	SOT-23	- 40°C to +85°C
AME8500CEETBF46Y	ARWww	4.63V	TSOT-23	- 40°C to +85°C
AME8500CEETCA21	ASZww	2.10V	SOT-23	- 40°C to +85°C
AME8500CEETCA21L	ASZww	2.10V	TSOT-23	- 40°C to +85°C
AME8500CEETCA21Z	ASZww	2.10V	SOT-23	- 40°C to +85°C
AME8500CEETCA21Y	ASZww	2.10V	TSOT-23	- 40°C to +85°C

**■ Ordering Information (contd.)**

Part Number	Marking*	Detect Voltage	Package	Operating Ambient Temperature Range
AME8500AEETAF20	BDTww	2.00V	SOT-23	- 40°C to +85°C
AME8500AEETAF20L	BDTww	2.00V	TSOT-23	- 40°C to +85°C
AME8500AEETAF20Z	BDTww	2.00V	SOT-23	- 40°C to +85°C
AME8500AEETAF20Y	BDTww	2.00V	TSOT-23	- 40°C to +85°C
AME8500BEETBE42	BDUww	4.20V	SOT-23	- 40°C to +85°C
AME8500BEETBE42L	BDUww	4.20V	TSOT-23	- 40°C to +85°C
AME8500BEETBE42Z	BDUww	4.20V	SOT-23	- 40°C to +85°C
AME8500BEETBE42Y	BDUww	4.20V	TSOT-23	- 40°C to +85°C
AME8500BEETBF45	BDXww	4.50V	SOT-23	- 40°C to +85°C
AME8500BEETBF45L	BDXww	4.50V	TSOT-23	- 40°C to +85°C
AME8500BEETBF45Z	BDXww	4.50V	SOT-23	- 40°C to +85°C
AME8500BEETBF45Y	BDXww	4.50V	TSOT-23	- 40°C to +85°C
AME8500AEETBE40	BEBww	4.0V	SOT-23	- 40°C to +85°C
AME8500AEETBE40L	BEBww	4.0V	TSOT-23	- 40°C to +85°C
AME8500AEETBE40Z	BEBww	4.0V	SOT-23	- 40°C to +85°C
AME8500AEETBE40Y	BEBww	4.0V	TSOT-23	- 40°C to +85°C
AME8500BEEVBE31	BEDww	3.08V	SOT-25	- 40°C to +85°C
AME8500BEEVBE31L	BEDww	3.08V	TSOT-25	- 40°C to +85°C
AME8500BEEVBE31Z	BEDww	3.08V	SOT-25	- 40°C to +85°C
AME8500BEEVBE31Y	BEDww	3.08V	TSOT-25	- 40°C to +85°C
AME8500AEETBE31Z	BEEww	3.08V	SOT-23	- 40°C to +85°C
AME8500AEETBE31Y	BEEww	3.08V	TSOT-23	- 40°C to +85°C
AME8500CEFTBA27	A8500C BA27ww	2.70V	SOT-89	- 40°C to +85°C
AME8500CEFTBA27Z	A8500C BA27ww	2.70V	SOT-89	- 40°C to +85°C
AME8500CEFTBA29	A8500C BA29ww	2.93V	SOT-89	- 40°C to +85°C
AME8500CEFTBA29Z	A8500C BA29ww	2.93V	SOT-89	- 40°C to +85°C

**■ Ordering Information (contd.)**

<b>Part Number</b>	<b>Marking*</b>	<b>Detect Voltage</b>	<b>Package</b>	<b>Operating Ambient Temperature Range</b>
AME8500CEFTBA42	A8500C BA42ww	4.20V	SOT-89	- 40°C to +85°C
AME8500CEFTBA42Z	A8500C BA42ww	4.20V	SOT-89	- 40°C to +85°C
AME8500BEETBE46Z	BLCww	4.63V	SOT-23	- 40°C to +85°C
AME8500BEETCF31Z	BLAww	3.08V	SOT-23	- 40°C to +85°C
AME8500AEETBA28Z	BKVww	2.80V	SOT-23	- 40°C to +85°C
AME8500AEETAA27Z	BKWww	2.70V	SOT-23	- 40°C to +85°C
AME8500AEETBF29Z	BJAww	2.93V	SOT-23	- 40°C to +85°C
AME8500AEETCF44Z	ALSww	4.38V	SOT-23	- 40°C to +85°C

**■ Absolute Maximum Ratings**

Parameter	Maximum	Unit
Supply Voltage	7	V
Input Current, $V_{IN}$	20	mA
Output Current, RESET, ResetB	20	mA
Rate of Rise, $V_{IN}$	100	V/ $\mu$ s
ESD Classification	B*	

Caution: Stress above the listed absolute maximum rating may cause permanent damage to the device

\* HBM B: 2000V~3999V

**■ Recommended Operating Conditions**

Parameter	Symbol	Rating	Unit
Ambient Temperature Range	$T_A$	- 40 to +85	$^{\circ}$ C
Junction Temperature Range	$T_J$	- 40 to +125	$^{\circ}$ C
Storage Temperature Range	$T_{STG}$	- 65 to +150	$^{\circ}$ C

**■ Thermal Information**

Parameter	Package	Die Attach	Symbol	Maximum	Unit
Thermal Resistance (Junction to Case)	SOT-23 TSOT-23**	Conductive Epoxy	$\theta_{JC}$	81	°C / W
		Non-Conductive Epoxy		140	
	SOT-25 TSOT-25**	Non-Conductive Epoxy		140	
		SOT-89*		Conductive Epoxy	
	Non-Conductive Epoxy			46	
	Thermal Resistance (Junction to Ambient)	SOT-23 TSOT-23		Conductive Epoxy	
Non-Conductive Epoxy			280		
SOT-25 TSOT-25		Non-Conductive Epoxy	280		
		SOT-89	Conductive Epoxy	180	
Non-Conductive Epoxy			180		
Internal Power Dissipation		SOT-23 TSOT-23	Conductive Epoxy	$P_D$	400
	Non-Conductive Epoxy		400		
	SOT-25 TSOT-25	Non-Conductive Epoxy	400		
		SOT-89	Conductive Epoxy		550
	Non-Conductive Epoxy		550		
	Maximum Junction Temperature				150
Solder Iron (10 Sec)***				350	°C

\* Measure  $\theta_{JC}$  on backside center of tab.

\*\* Measure  $\theta_{JC}$  on center of molding compound if IC has no tab.

\*\*\* MIL-STD-202G 210F

**■ Electrical Specifications**
 $T_A = 25^\circ\text{C}$  unless otherwise noted

Parameter	Symbol	Test Condition		Min	Typ	Max	Units
$V_{IN}$ Range	$V_{RANGE}$	$T_A = -40^\circ\text{C} \sim +85^\circ\text{C}$		1		5.5	V
Supply Current	$I_{IN}$	$V_{IN} = V_{TH} * 1.10$				3.0	$\mu\text{A}$
		$V_{IN} = V_{TH} * 1.10, T_A = -40^\circ\text{C} \sim +85^\circ\text{C}$				5.0	
Reset Threshold	$V_{TH}$			$V_{TH(NOM)} - 1.5\%$		$V_{TH(NOM)} + 1.5\%$	mV
		$T_A = -40^\circ\text{C} \sim +85^\circ\text{C}$		$V_{TH(NOM)} - 2.0\%$		$V_{TH(NOM)} + 2.0\%$	
Hysteresis Range (Note2)	$V_{HYST}$	$V_{Release} - V_{TH}$ (Note1)		10	30	60	mV
RESET Threshold Tempco (Note 2)				30	50	160	ppm
RESETB Output Voltage Low	$V_{OL}$	$V_{IN} < V_{TH (MIN)}$	$I_{SINK} = 1.2\text{mA}, T_A = -40^\circ\text{C} \sim +85^\circ\text{C}$			0.2	V
RESET Output Voltage Low		$V_{IN} > V_{TH (MAX)}$					
RESETB Output Voltage High	$V_{OH}$	$V_{IN} > V_{TH (MAX)}$	$I_{SOURCE} = 0.5\text{mA}, V_{IN} > 1.8\text{V}$	0.8 $V_{IN}$			V
RESET Output Voltage High							
RESET Output Voltage High			$I_{SOURCE} = 0.5\text{mA}, V_{IN} > 1.8\text{V}$				
			$I_{SOURCE} = 0.15\text{mA}, 1.8\text{V} \geq V_{IN} > 1.0\text{V}$				
$V_{IN}$ to Reset Delay	$T_{D1}$	$V_{IN} = V_{TH} - 100\text{mV}, T_A = -40^\circ\text{C} \sim +85^\circ\text{C}$			40		$\mu\text{S}$
Reset Timeout Period	$T_{D2}$	$T_A = -40^\circ\text{C} \sim +85^\circ\text{C}$	Version A	0.5	1.5	5	mS
			Version E	80	150	230	mS
			Version F	140	210	500	mS

 Note1: The data based on  $V_{TH} = 2.7\text{V}$  part type.

Note2: Guaranteed by Design

### ■ Timing Diagram

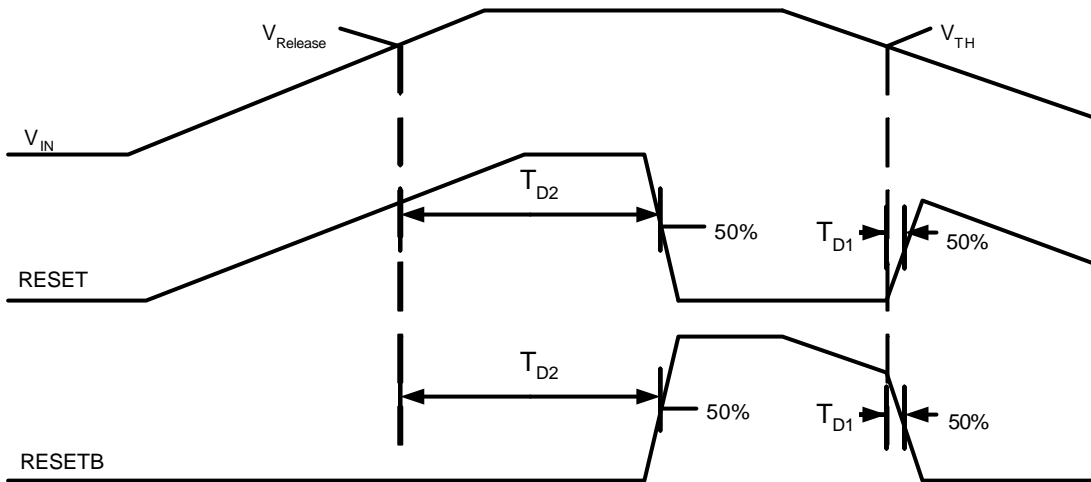

### ■ Applications Information

#### Supply Transients

These devices have a certain immunity to fast negative going transients. In the following pages the graph titled "Glitch Rejection" indicates the maximum allowable glitch amplitude and duration to avoid triggering an unintended reset. As shown in the graph shorter transients can have larger amplitudes without triggering resets.

### ■ Characterization Curve

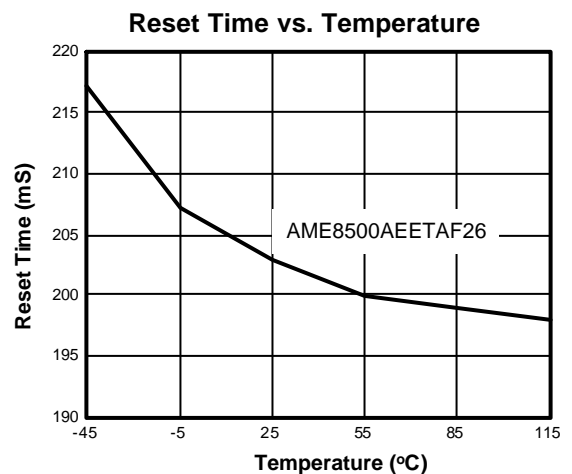
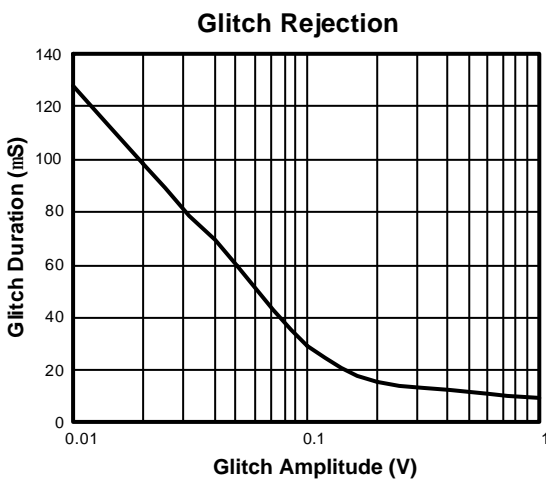

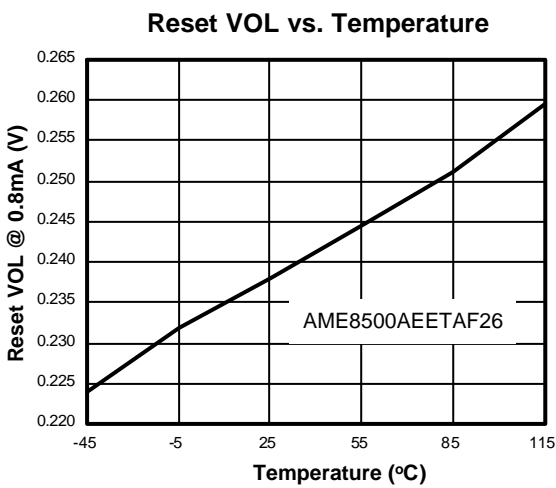
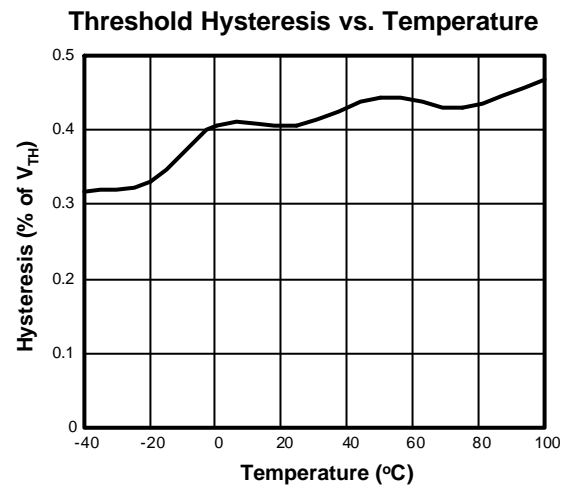
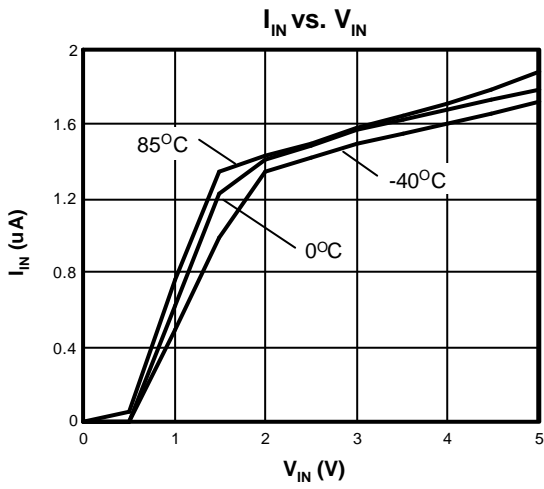
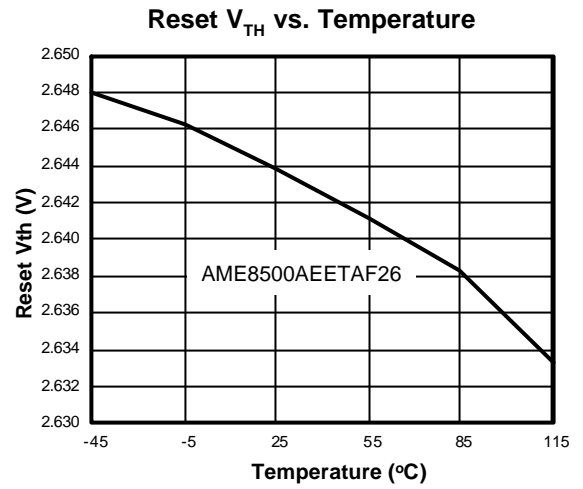
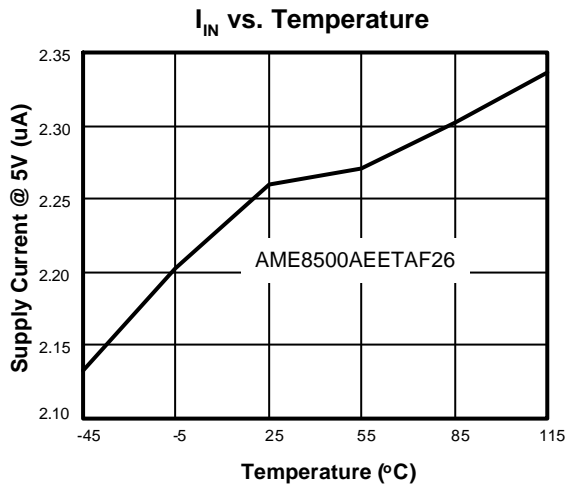
**■ Characterization Curve(contd.)**



**■ Date Code Rule**

Marking			Date Code		Year
A	A	A	W	W	xxx0
A	A	A	W	<u>W</u>	xxx1
A	A	A	<u>W</u>	W	xxx2
A	A	A	<u>W</u>	<u>W</u>	xxx3
A	A	<u>A</u>	W	W	xxx4
A	A	<u>A</u>	W	<u>W</u>	xxx5
A	A	<u>A</u>	<u>W</u>	W	xxx6
A	A	<u>A</u>	<u>W</u>	<u>W</u>	xxx7
A	<u>A</u>	A	W	W	xxx8
A	<u>A</u>	A	W	<u>W</u>	xxx9

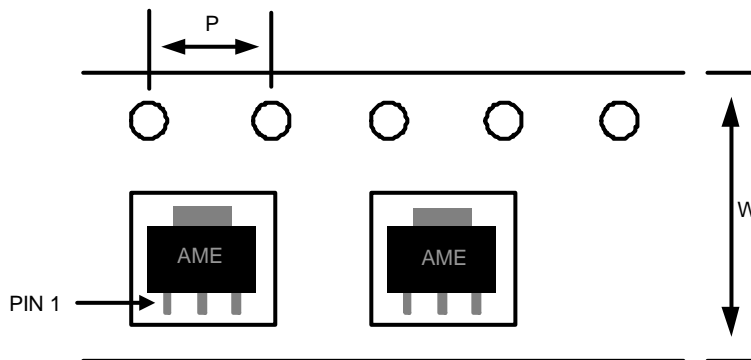
**■ Tape and Reel Dimension**
**SOT-89**

**Carrier Tape, Number of Components Per Reel and Reel Size**

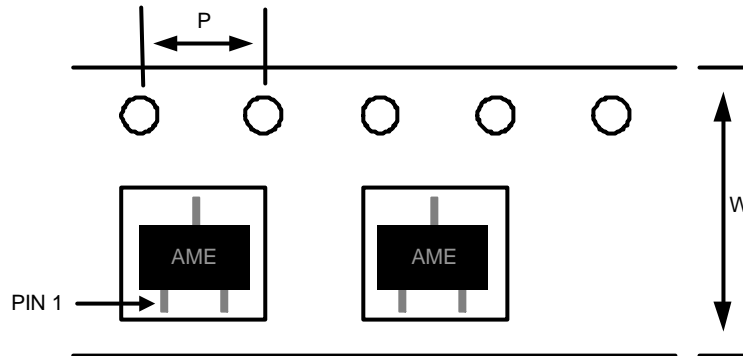
Package	Carrier Width (W)	Pitch (P)	Part Per Full Reel	Reel Size
SOT-89	12.0±0.1 mm	4.0±0.1 mm	1000pcs	180±1 mm

**■ Tape and Reel Dimension**
**SOT-23**

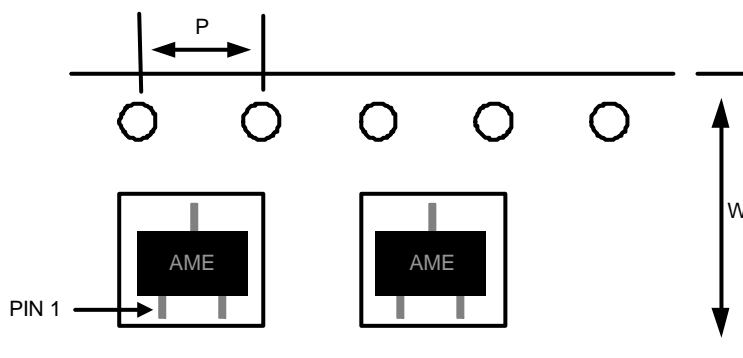
**Carrier Tape, Number of Components Per Reel and Reel Size**

Package	Carrier Width (W)	Pitch (P)	Part Per Full Reel	Reel Size
SOT-23	8.0±0.1 mm	4.0±0.1 mm	3000pcs	180±1 mm

**TSOT-23**

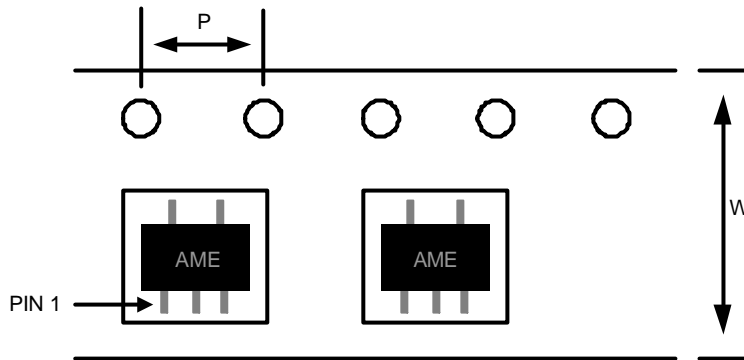
**Carrier Tape, Number of Components Per Reel and Reel Size**

Package	Carrier Width (W)	Pitch (P)	Part Per Full Reel	Reel Size
TSOT-23	8.0±0.1 mm	4.0±0.1 mm	3000pcs	180±1 mm

**■ Tape and Reel Dimension**
**SOT-25**

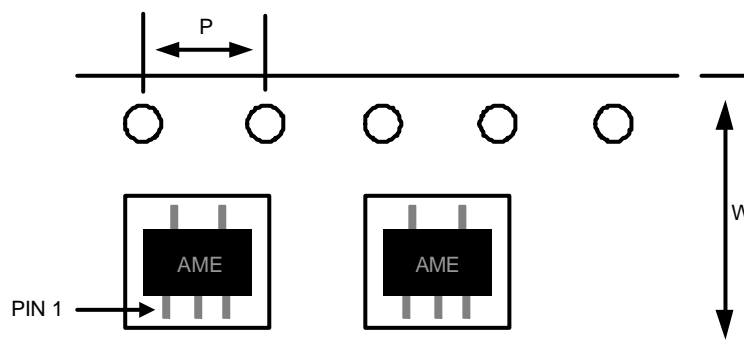
**Carrier Tape, Number of Components Per Reel and Reel Size**

Package	Carrier Width (W)	Pitch (P)	Part Per Full Reel	Reel Size
SOT-25	8.0±0.1 mm	4.0±0.1 mm	3000pcs	180±1 mm

**TSOT-25**

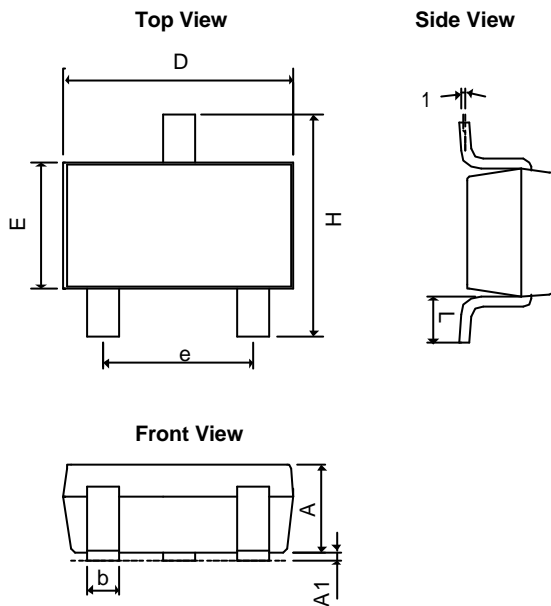
**Carrier Tape, Number of Components Per Reel and Reel Size**

Package	Carrier Width (W)	Pitch (P)	Part Per Full Reel	Reel Size
TSOT-25	8.0±0.1 mm	4.0±0.1 mm	3000pcs	180±1 mm

**■ Package Dimension**
**SOT-23**

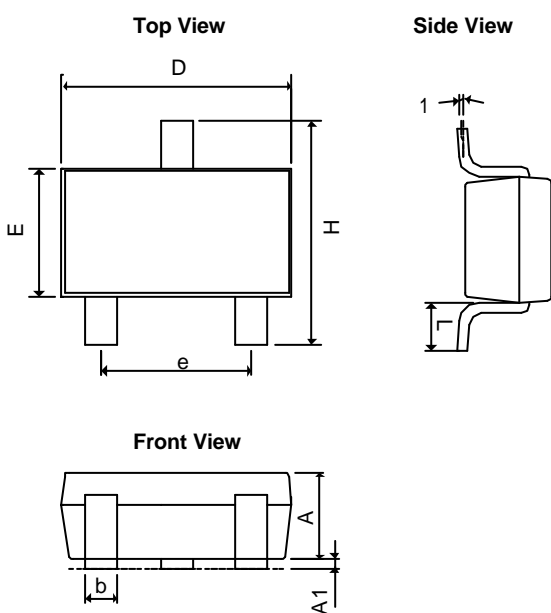
SYMBOLS	MILLIMETERS		INCHES	
	MIN	MAX	MIN	MAX
A	1.00	1.40	0.0394	0.0551
A <sub>1</sub>	0.00	0.15	0.0000	0.0059
b	0.35	0.50	0.0138	0.0197
D	2.70	3.10	0.1063	0.1220
E	1.40	1.80	0.0551	0.0709
e	1.90 BSC		0.0748 BSC	
H	2.40	3.00	0.09449	0.11811
L	0.35BSC		0.0138BSC	
q1	0°	10°	0°	10°

**TSOT-23**

SYMBOLS	MILLIMETERS		INCHES	
	MIN	MAX	MIN	MAX
A+A <sub>1</sub>	0.80	1.30	0.0315	0.0512
b	0.35	0.50	0.0138	0.0197
D	2.70	3.10	0.1063	0.1220
E	1.20	1.80	0.0472	0.0709
e	1.90 BSC		0.0748 BSC	
H	2.40	3.00	0.09449	0.11811
L	0.35BSC		0.0138BSC	
q1	0°	10°	0°	10°

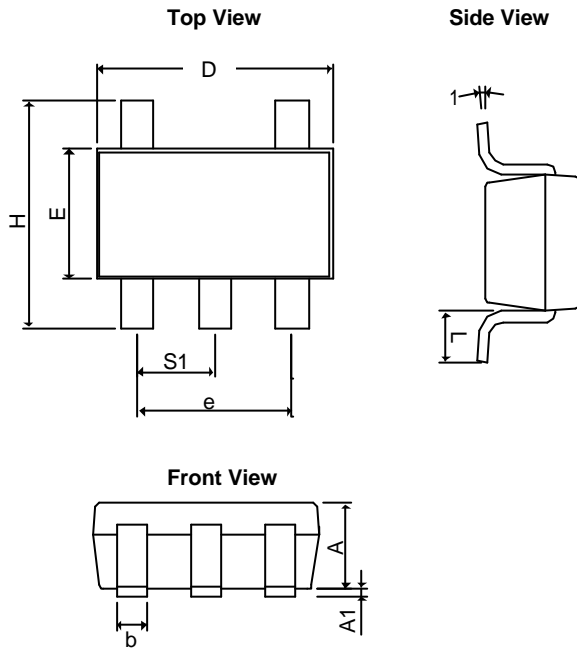
**■ Package Dimension**
**SOT-25**

SYMBOLS	MILLIMETERS		INCHES	
	MIN	MAX	MIN	MAX
<b>A</b>	1.20REF		0.0472REF	
<b>A<sub>1</sub></b>	0.00	0.15	0.0000	0.0059
<b>b</b>	0.30	0.55	0.0118	0.0217
<b>D</b>	2.70	3.10	0.1063	0.1220
<b>E</b>	1.40	1.80	0.0551	0.0709
<b>e</b>	1.90 BSC		0.07480 BSC	
<b>H</b>	2.60	3.00	0.10236	0.11811
<b>L</b>	0.37BSC		0.0146BSC	
<b>q1</b>	0°	10°	0°	10°
<b>S<sub>1</sub></b>	0.95BSC		0.0374BSC	

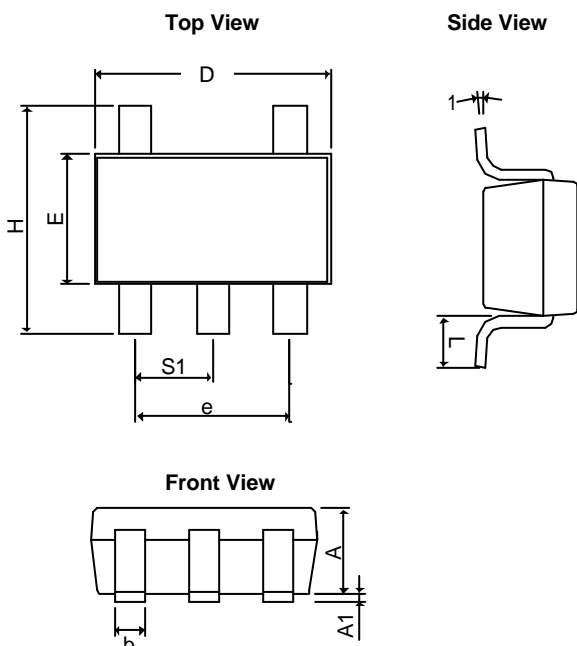
**TSOT-25**

SYMBOLS	MILLIMETERS		INCHES	
	MIN	MAX	MIN	MAX
<b>A+A<sub>1</sub></b>	0.90	1.25	0.0354	0.0492
<b>b</b>	0.30	0.50	0.0118	0.0197
<b>D</b>	2.70	3.10	0.1063	0.1220
<b>E</b>	1.40	1.80	0.0551	0.0709
<b>e</b>	1.90 BSC		0.07480 BSC	
<b>H</b>	2.40	3.00	0.09449	0.11811
<b>L</b>	0.35BSC		0.0138BSC	
<b>q1</b>	0°	10°	0°	10°
<b>S<sub>1</sub></b>	0.95BSC		0.0374BSC	

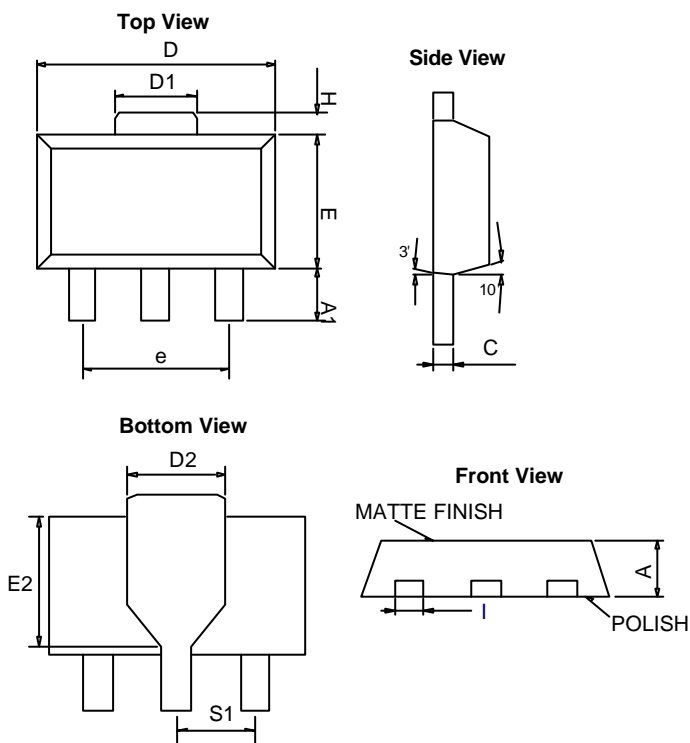
**■ Package Dimension**
**SOT-89**

SYMBOLS	MILLIMETERS		INCHES	
	MIN	MAX	MIN	MAX
<b>A</b>	1.39	1.60	0.05472	0.06299
<b>A<sub>1</sub></b>	0.8 REF		0.03150 REF	
<b>C</b>	0.35	0.44	0.01378	0.01732
<b>D</b>	4.39	4.60	0.17283	0.18110
<b>D<sub>1</sub></b>	1.35	1.83	0.05315	0.07205
<b>E</b>	2.28	2.60	0.08976	0.10236
<b>I</b>	0.36	0.56	0.01417	0.02204
<b>e</b>	3.00 REF		0.11811 REF	
<b>H</b>	0.70 REF		0.02756 REF	
<b>S<sub>1</sub></b>	1.50 REF		0.05906 REF	
<b>E<sub>2</sub></b>	2.05	2.60	0.08071	0.10236
<b>D<sub>2</sub></b>	1.50	1.85	0.05905	0.07283



**www.ame.com.tw**  
**E-Mail: sales@ame.com.tw**

Life Support Policy:

These products of AME, Inc. are not authorized for use as critical components in life-support devices or systems, without the express written approval of the president of AME, Inc.

AME, Inc. reserves the right to make changes in the circuitry and specifications of its devices and advises its customers to obtain the latest version of relevant information.

© AME, Inc. , September 2009  
Document: 2007/2055/1221-DS8500-T.10

**Corporate Headquarter**  
**AME, Inc.**

2F, 302 Rui-Guang Road, Nei-Hu District  
Taipei 114, Taiwan.  
Tel: 886 2 2627-8687  
Fax: 886 2 2659-2989