

SPECIFICATIONS

PARAMETERS	VALUES	UNITS
RATED INPUT POWER	3	W
MAX INPUT POWER	4	W
IMPEDANCE	4 ± 15%	OHM
OUTPUT SPL @ 1W/1M (AT 1.0, 1.2, 1.5, 2.0 kHz)	82 ± 3	dBA
DISTORTION (MAX.)	5%	-
RESONANT FREQUENCY	420 ± 20%	Hz
FREQUENCY RANGE	200 ~ 20,000	Hz
HOUSING MATERIAL	ABS	-
CONE MATERIAL	TREATED PAPER	-
MAGNET MATERIAL	RARE EARTH	-
OPERATING TEMPERATURE	-10 ~ +55	°C
WEIGHT	11.9	grams

THIS DOCUMENT CONTAINS DATA PROPRIETARY TO PROJECTS UNLIMITED, INC. ANY USE OR REPRODUCTION, IN ANY FORM, WITHOUT PRIOR WRITTEN PERMISSION OF PROJECTS UNLIMITED, INC. IS PROHIBITED.
©2003, Projects Unlimited Inc.

REVISION HISTORY

LTR	DESCRIPTION	DATE	APPROVED
-	RELEASED FROM ENGINEERING	12/7/2005	
A	REVISED TO INVENTOR 3-D DRAWING TEMPLATE	6/27/2008	B.R.
B	ADDED NOTE 5	8/11/2011	B.R.

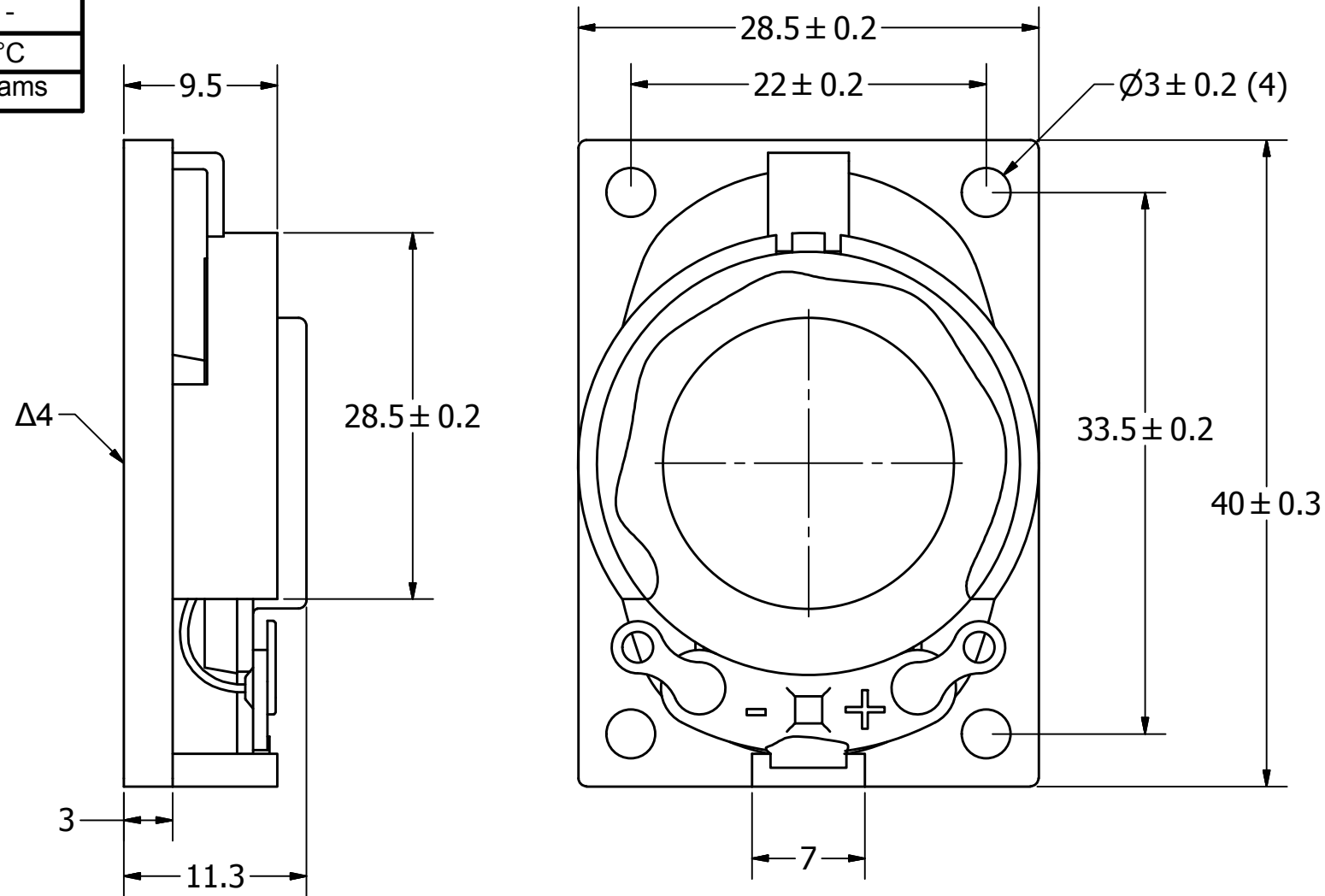

NOTES:

1. ALL DIMENSIONS ARE IN MILLIMETERS.
2. SPECIFICATIONS SUBJECT TO CHANGE OR WITHDRAWL WITHOUT NOTICE.
3. THIS PART IS RoHS 2002/95/EC COMPLIANT.
- Δ4. CONE HAS BEEN TREATED FOR WATER RESISTANCE.
5. BASE SPEAKER PUI# AS04004PO-2-R.

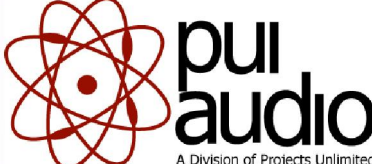
UNLESS OTHERWISE SPECIFIED: DIMENSIONS ARE IN MILLIMETERS, TOLERANCES ARE ±0.5 AND ANGLES ARE ±3°.	SIZE A3	Designed by	Date	Checked by	Date	Approved by	Date	Drawn Date	
		J.D.	12/6/2005	B.R.	12/6/2005	E.P.	12/6/2005	6/27/2008	
AS04004PO-2-WR-R.idw				AS04004PO-2-WR-R Speaker				Edition	Sheet
								-	1 / 1

Mouser Electronics

Authorized Distributor

Click to View Pricing, Inventory, Delivery & Lifecycle Information:

[PUI Audio:](#)

[AS04004PO-2-WR-R](#)