

Stingray Chassis Kit (#28980)

This highly versatile mobile robot platform sports a stealthy low-profile design packed with sleek curves and a convenient form factor that is perfect for a variety of mid-sized robotic projects. The chassis is constructed from 1/16 inch thick (1.58 mm) 5052 aluminum sheet metal with a lightly grained black anodized finish for increased durability and scratch resistance.

Robust 7.2 VDC motors with all-metal-gear construction use machined aluminum hubs to positively engage the 4 7/8 inch (12.4 cm) diameter wheels. The result is a solid and reliable robot chassis that moves with smoothness and quick agility. The motor's speed is 310 RPM at 7.2 V which equates to approximately 6.6 feet/sec (2.0 m/s).

Each chassis panel comes furnished with a variety of mounting holes and slots to accommodate a wide range of control boards and accessories. With almost limitless possibilities you can have an autonomous mobile robot up and running in no-time. Let your mind escape with the Stingray Chassis Kit!

Features

- High-quality, scratch-resistant, type-2 anodized aluminum alloy chassis
- Solid 4 7/8 inch (12.4 cm) diameter wheels with durable high-traction rubber tread
- Durable 7.2 VDC motors have all metal gears
- Two-wheel differential drive system with rear omni-directional wheel
- Multiple mounting locations for sensors, add-ons, etc.

Key Specifications

- Power requirements: Motors rated @ 7.2V (stall current 4.5A @ 7.2V)
- Communication: N/A (depends on control board used)
- Operating temperature: 32 to 158 °F (0 to 70 °C)
- Dimensions, assembled: 13" L x 10.9" W x 5.5" H (33 x 27.7 x 14 cm)



Bill of Materials

This table contains a complete list of the parts used in this kit at the time this document was created. Parts and quantities are subject to change without notice. If you have any questions about your kit contents, please contact Parallax through the Tech Support Resources listed on page 13.

Part #	Description	Quantity
27950	Motor, 7.2VDC, 310 RPM, 6mm Shaft	2
700-00028	Screw, Zinc, Pan Head, Phillips, #4-40, 1/4"	8
700-00064	Parallax Screwdriver (Phillips/flathead combination)	1
710-00017	Screw, Black, Button Socket Cap, #4-40, 1/4"	34
710-00018	Screw, Black, Button Socket Cap, M3, 6mm	6
710-00020	Screw, Zinc, Pan Head, Phillips, #8-32, 3/8"	4
713-00001	Standoff, Aluminum, 1/4" W, Round, 5/8" L, #4-40	4
721-00008	Wheel, 4-7/8" Diameter, Blue Tread	2
721-00009	Wheel Hub, Aluminum, 6 mm Shaft (includes o-ring and set screw)	2
725-00062	Hex Key, 1/16"	1
725-00068	Hex Key, 2 mm	1
730-00050	Stingray Chassis Plate	2
730-00051	Stingray Motor Mount Plate	2
730-00052	Stingray Sensor Mount Plate	5
730-00053	Stingray Tail Wheel Mount Plate	1
730-00054	Multi-Directional Tail Wheel (Omni-Wheel)	1
730-00055	Stingray Tail Wheel Axle	1
730-00056	Handle, Aluminum, 3" Length, #8-32 Screw	2
800-28900	Wire, 2-Conductor (Green/White), 20AWG, 10"	1
800-28980	Wire, 2-Conductor (Blue/White), 20AWG, 10"	1

Assembly Instructions

This section will guide you step-by-step as you assemble your Stingray Chassis Kit. Each step will describe the parts and tools required and then the procedure to assemble them. Each step contains a CAD drawing as a visual aid to the instructions. Be sure to follow each step carefully.

Preparation

- ✓ Match the Bill of Materials against the parts in your kit to make sure all parts are present.
- ✓ Find a clean workspace on which to assemble your chassis. You might want to put down some newspaper or cardboard so that the edges of the metal parts do not scratch the work surface.
- ✓ Organize tools and parts prior to starting the assembly and separate parts by type to make it easier to gather them during the assembly process.
- ✓ Throughout the assembly process, when tightening screws be sure to get them nice and snug but do not over-tighten them or you may strip the threads or heads of screws.

Additional Tools Required

Two hex keys and one Phillips/flathead screwdriver are provided. The following additional tools are required:

- Safety glasses
- Small pair of needle-nosed pliers
- O-ring pliers if you have them (these are optional, but make things easier)

STEP 1: Chassis Assembly (lower)

Parts Required

- (1) Stingray Chassis Plate
- (5) Stingray Sensor Mount Plate
- (2) Stingray Motor Mount Plate
- (1) Stingray Tail Wheel Mount Plate
- (16) Screw, Black, Button Socket Cap, #4-40, 1/4"

Tools Required

- ✓ 1/16" Hex Key (included)
- ✓ Use the 1/16" Hex Key and the black #4-40 black button socket cap screws in this step. (Note that there are also 6 button socket cap screws and a 2 mm Hex Key; be careful to use the correct type.)
- ✓ Attach the Tail Wheel Mount Plate and Sensor Mount Plates to the Chassis Plate in the orientation shown below.
- ✓ Attach the Motor Mount Plates, being very careful to orient them correctly so that one screw hole is close to the Chassis Plate, which will be the bottom of the robot chassis.

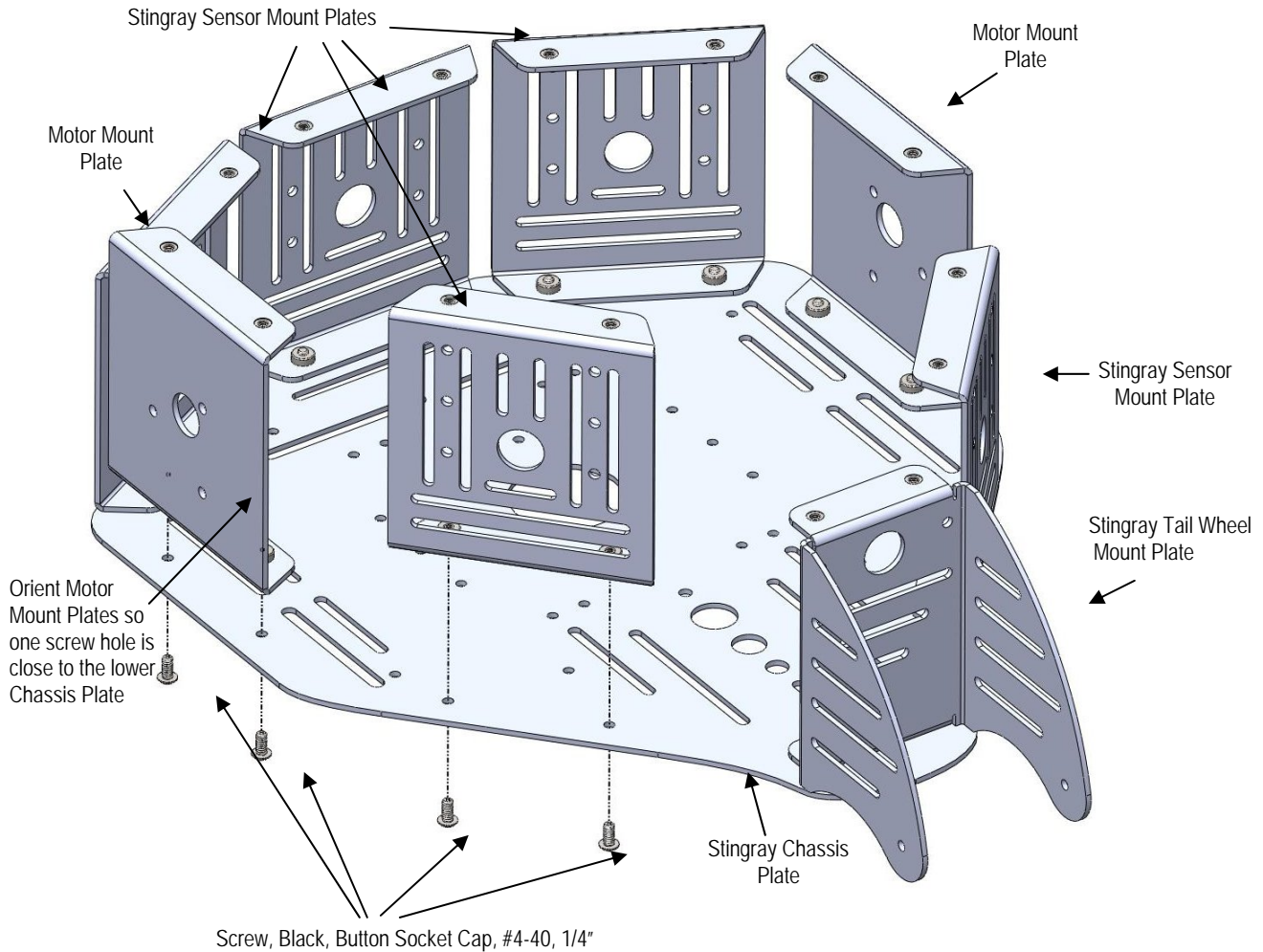

STEP 2: Motor Installation

Parts Required

- (2) Motor, 7.2 VDC, 310RPM, 6 mm Shaft
- (6) Screw, Black, Button Socket Cap, M3, 6 mm

Tools Required

- 2 mm Hex Key (included)

- ✓ Using the included 2 mm Hex Key attach the motors to the Motor Mount Plates using 3 each of the M3 screws as shown in the figure below. The main body of the motors should be toward the bottom of the robot chassis while the shaft should be toward the top.
- ✓ Be sure all three screws in each motor are very snug, but do not over-tighten.

Please note that the six M3 screws look very similar to the ones used on the chassis assembly in the previous step. To distinguish them from the others you can see that the hex hole in the head of the M3 is larger and uses the 2 mm (larger) Hex Key.

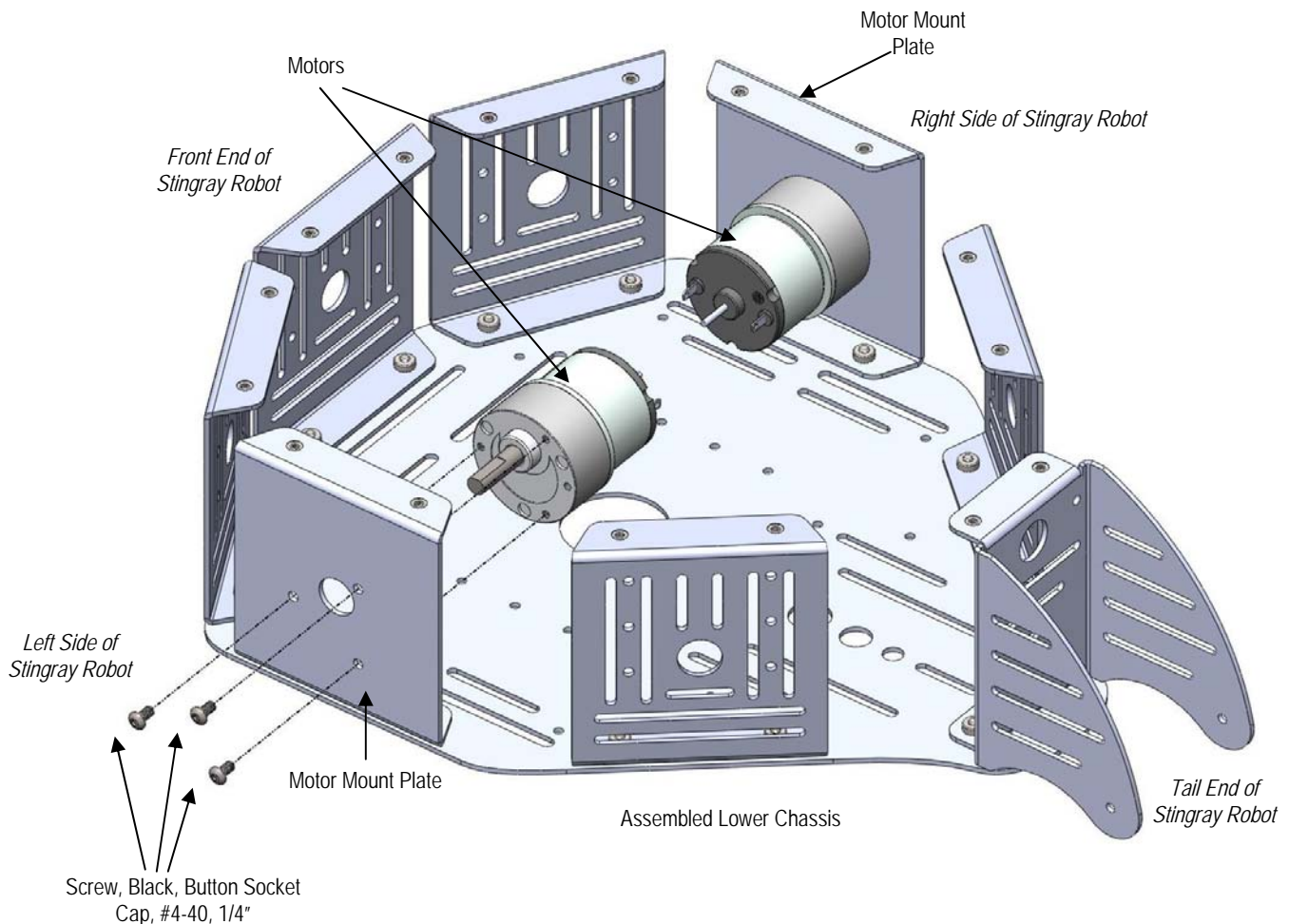

STEP 3: Motor Wire Connection

Parts Required

- (1) Wire, 2-Conductor (Green/White), 20AWG, 10"
- (1) Wire, 2-Conductor (Blue/White), 20AWG, 10"

Tools Required

- None

There are two Motor Wire Assemblies. One has a Green/White wire pair while the other has a Blue/White wire pair.

- ✓ Connect the Green/White Motor Wire Assembly to the *left* motor (shown) so that the green wire connects to the positive terminal and the white wire connects to the other terminal. See the figure below for details.
- ✓ Repeat the procedure for the *right* motor making sure to connect the blue wire to the positive terminal and the white wire to the other terminal.
- ✓ If the wire set contains a Molex connector like the one shown below it can simply be removed by cutting it from the end of the wire pair.

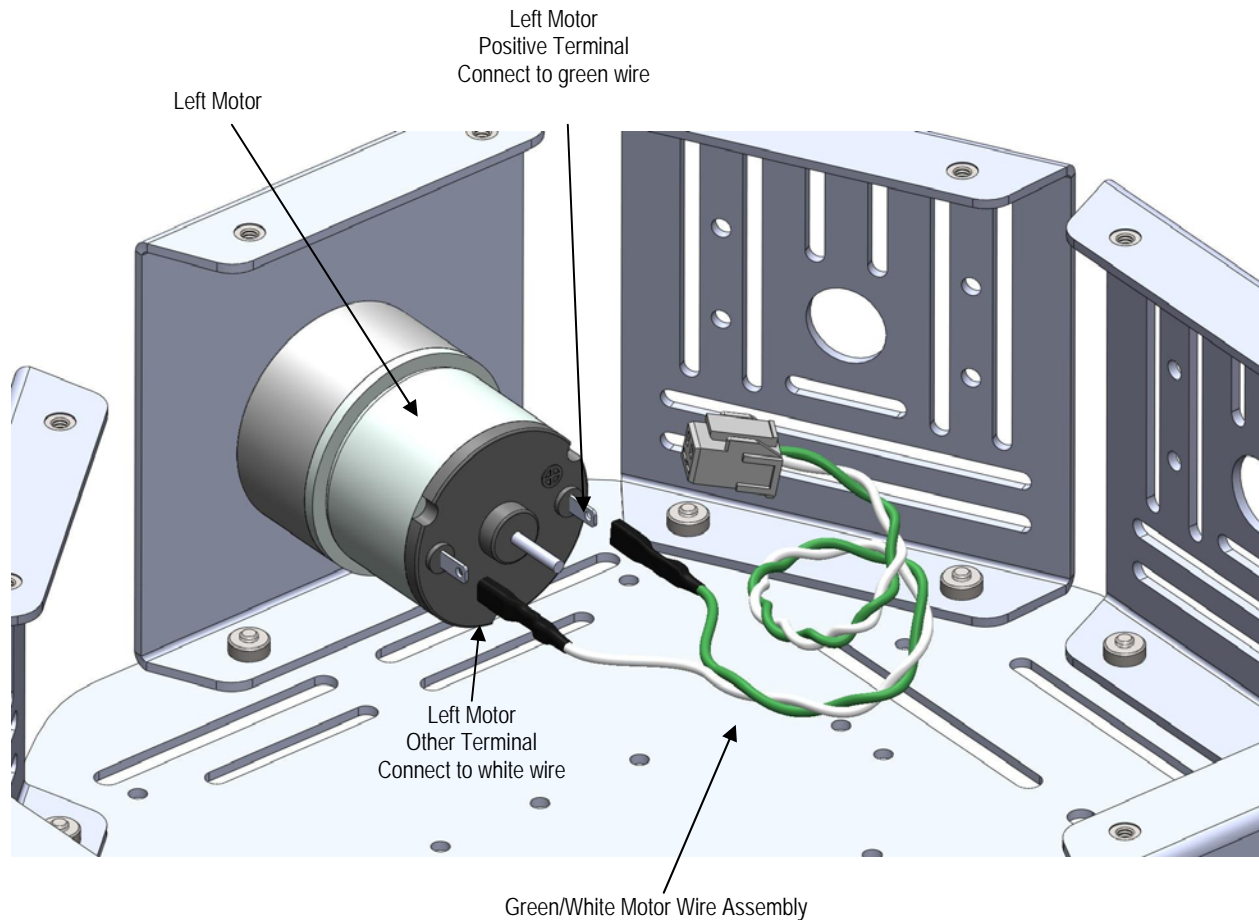

STEP 4: Hub Installation

Parts Required

- (1) Wheel Hub, Aluminum, 6mm Shaft
- (4) Hub Set Screws (included with hubs)

Tools Required

- 1/16" Hex Key (included)

- ✓ Using the included 1/16" Hex Key, install 2 set screws loosely into each Wheel Hub as shown in the figure below.
- ✓ Slide the hub onto the motor shaft so that the screws line up with the flat part of the motor shaft. The hub should slide all the way onto the shaft with just a small gap ($< 1/16"$) between the hub and the motor casing protruding through the motor mount plate.
- ✓ Both set screws should land on the flat part of the motor shaft when tightened down.
- ✓ Gently tighten the set screws. Be careful not to over-tighten the set screw but make sure it is very snug or the hub may work loose over time.
- ✓ Repeat this procedure for the other motor.

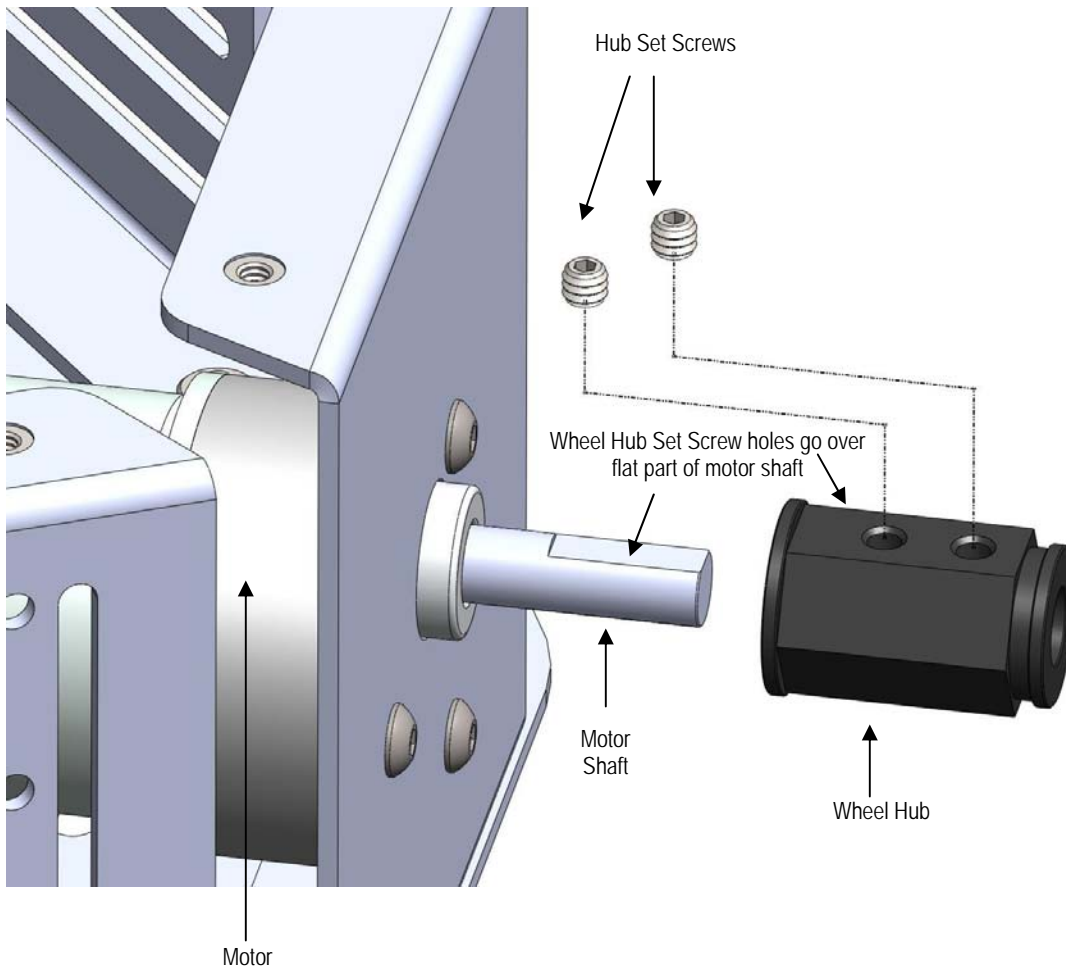

STEP 5: Front Wheel Installation

Parts Required

- (2) Wheel, 4-7/8" Diameter, Blue Tread
- (2) Hub o-ring (included with hubs)

Tools Required:

- Small pair of needle nosed pliers or snapping pliers (not included)
- Safety Glasses (not included)

- ✓ Be sure to wear your safety glasses during this step.
- ✓ Stand the robot chassis on its side so that the hub and wheel are facing upward as shown in the first figure below. This will make it easier to install the o-ring onto the hub.
- ✓ Slide one of the wheels onto a hub. You can either hold the robot chassis between your legs or have someone else hold it in place for this step.
- ✓ To install the o-ring, place it over the hub and hold the back part of the ring in place as shown in the upper right figure.
- ✓ Using the o-ring pliers or small needle nosed pliers, separate the front of the o-ring while pressing down lightly. This should cause it to snap into place into the groove on the hub as shown in the lower right figure.
- ✓ Repeat with other wheel.

Note: A video clip demonstrating how to do install the Hub o-ring with needle nosed pliers is available for download on the Stingray robot product page on our website.

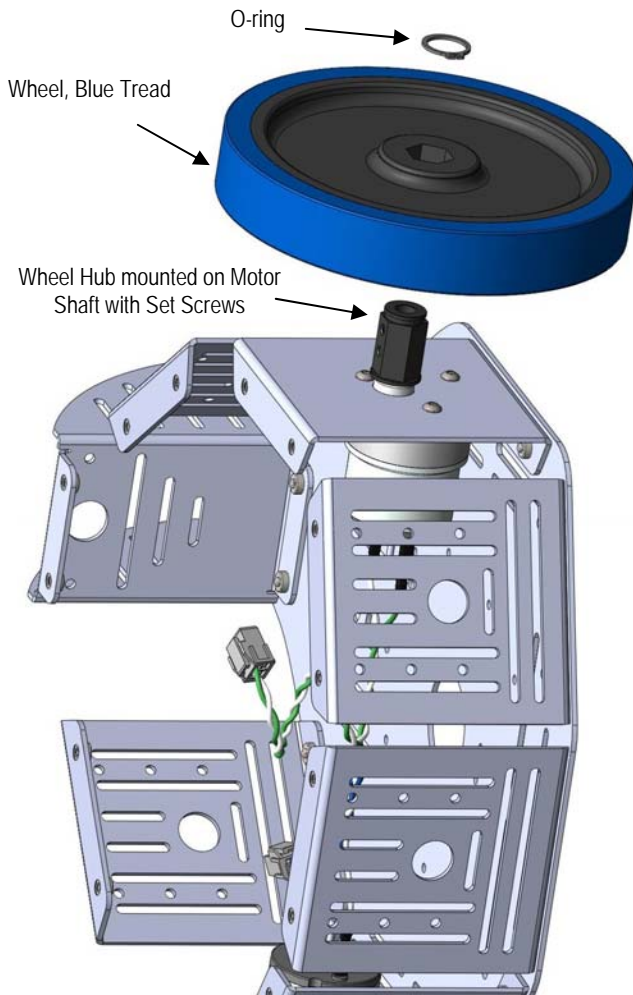

Place o-ring over the hub and hold the back part of the ring in place.

With pliers, separate the front of the o-ring while pressing down lightly.



When the O-ring snaps into place into the groove on the hub, release the pliers.



STEP 6: Tail Wheel Installation

Parts required

- (1) Multi-Directional Tail Wheel (Omni-Wheel)
- (1) Stingray Tail Wheel Axle
- (2) Screw, Black, Button Socket Cap, #4-40, 1/4"

Tools Required

- 1/16" Hex Key (included)

- ✓ Be sure the two halves of the Tail Wheel Assembly are joined.
- ✓ Slide the Tail Wheel Axle inside the Tail Wheel Assembly and place it between the fins of the Tail Wheel Mount Plate.
- ✓ Using the 1/16" Hex Key, insert the screws into each end of the axle as shown in the figure below.
- ✓ Be sure the axle screws are very snug or they may come loose over time.

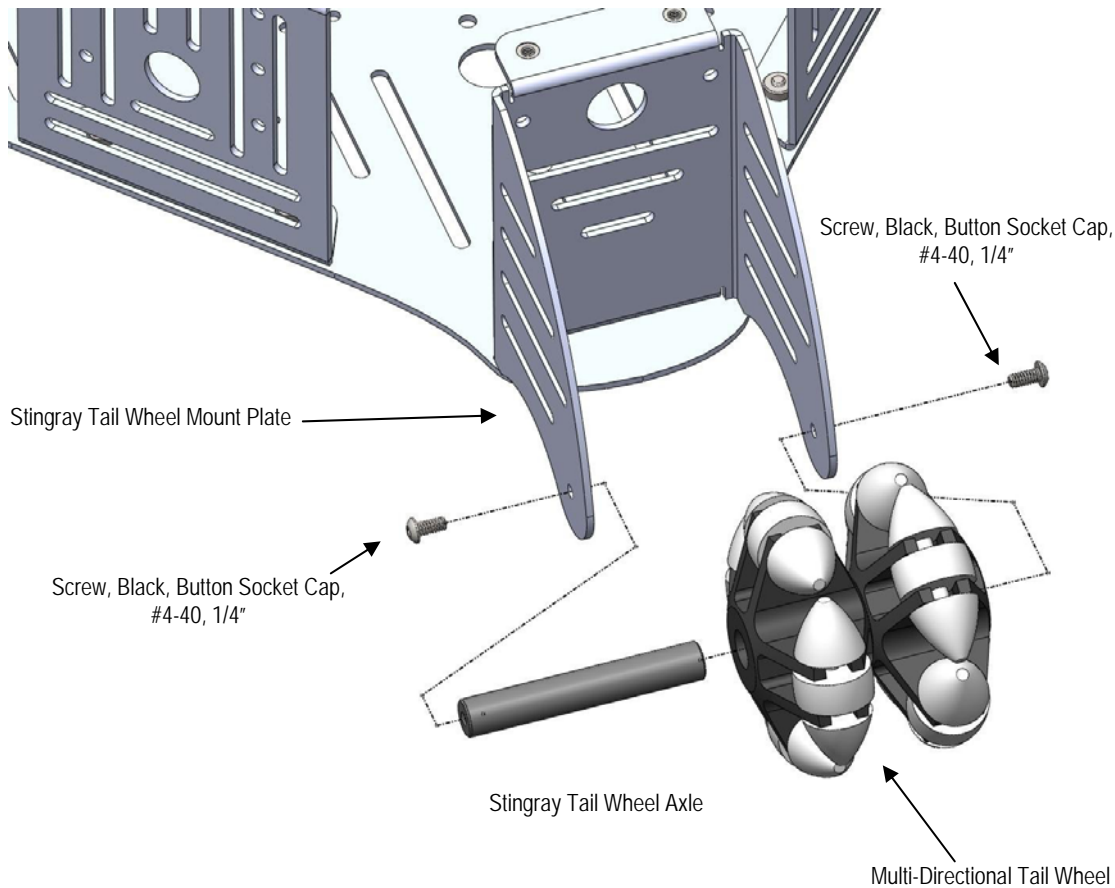

STEP 7: Chassis Assembly (upper)

Parts Required

- (1) Stingray Chassis Top Plate
- (2) Handle, Aluminum, 3" Length, #8-32 Screw
- (4) Screw, Zinc, Pan Head, Phillips, #8-32, 3/8"
- (4) Standoff, Aluminum, 1/4" W, Round, 5/8" L, #4-40
- (8) Screw, Zinc, Pan Head, Phillips, #4-40, 1/4"

Tools Required

- Parallax Screwdriver (included)
- 1/16" Hex Key (included)

- ✓ Position the Aluminum Handles over the Stingray Chassis Top Plate. The handles will only fit in the larger, outer slots on the left and right of the Chassis Plate.
- ✓ Using the Phillips end of the Parallax screwdriver, loosely attach the Aluminum Handles to the Chassis Plate using the #8-32 x 3/8" screws as shown in the figure below.
- ✓ Center each handle in the grooves and tighten the screws, careful not to over-tighten them.
- ✓ Using the Phillips end of the Parallax screwdriver, install the 8 standoffs into the holes shown below.

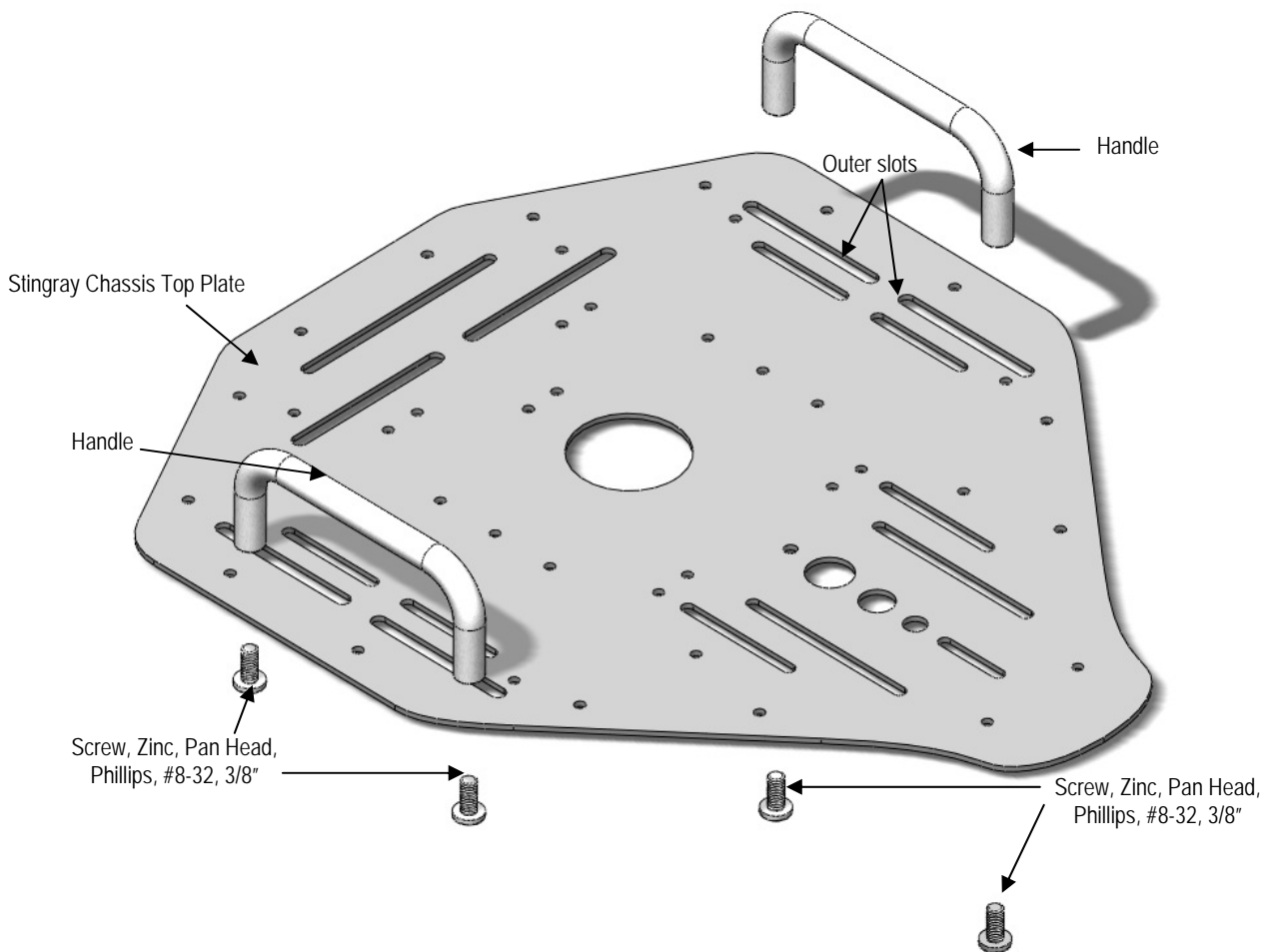

Completed Stingray Chassis Kit



Standoffs are included for mounting your control board. In the above picture they are shown ready to mount a Parallax board such as a Board of Education (#28850), Super Carrier Board (#27130) or Propeller Proto Board USB (#32812). These boards would require (2) HB-25 Motor Controllers (#29144) to facilitate motor control.

The Sensor Mount Plates are designed to work perfectly with our PING))) Ultrasonic Sensor (#28015). The mounting holes on the tops of the Sensor Mount Plates are friendly with our PING))) Protector Stand (#725-28015). A recommended power solution is our Li-ion Power Pack / Charger (#28986), an integrated storage and charging system using two Lithium Ion cells providing the correct voltage for the motors.

Driving Brushed DC Motors

Familiarize yourself with the motors included in the Stingray Chassis Kit so you can take advantage of the benefits of using these motors as well as understand the nuances. DC motors are usually driven by an H-bridge since such a circuit can reverse the polarity of the motor connected to it. Understanding how to control an H-bridge is the key to controlling the direction, speed and duration that the motors are on or off.

Brushed DC Spur-Gear Motors

The Stingray Chassis Kit was designed to be fast when needed and as such a method of locomotion was chosen to support this requirement. Servo motors used in many smaller robots are too slow and have too little load capacity for the Stingray chassis. Instead, brushed DC gear motors were selected. Specifically the motors used are known as Spur-Gear motors. These motors provide a good value and performance in a reasonably sized package.

The motors included in the Stingray Chassis Kit have the following specifications:

- 7.2 VDC Nominal @ ~180 mA (no load)
- 310 RPM (30:1 gear ratio on output shaft)
- 6mm diameter output shaft w/5.5mm detent for hubs with set screws
- Output shaft length: 18 mm (0.70")
- Motor shaft extends from back of motor allowing encoder support
- Motor shaft length: 10 mm (0.40")
- Four M3 size mounting holes



Internally the Spur-gear motor looks like the picture shown below, left. The back side of the motor is shown in the figure on the right. Take note of the (+) sign that is used to indicate polarity. While motors don't have a specific polarity per se, the plus signs help to match polarity of the motors on either side so you know the direction the motor will turn when you apply power to it. When you apply power to the motor so that the positive supply is connected to the (+) terminal and the other terminal connects to ground the internal motor shaft turns clockwise while the output shaft spins counter-clockwise.



Spur-gear motor
internals

Back side of motor; note
the ⊕ symbol to help
match polarity.



The motors are designed to run nominally at 7.2 VDC. This voltage was chosen due to the popularity of 7.2 V R/C battery packs used as power sources on robots and in R/C cars. Running the motors at voltages higher than 7.2 V can wear the brushes out quicker, reducing the life of the motor. Another thing to keep in mind with DC motors is that two motors of the same model, given the same voltage, may not spin at exactly the same speed. This is due to variations in the internal coils, magnets, etc. Similar to calibrating continuous rotation servos, DC motors must be calibrated in software to ensure the robot goes in a straight line. Because the motor shaft extends from the back of the motor you could also employ optical encoders and program your motor drive code to adjust motor speed based on feedback provided by the encoders, but that is a topic for a future update.

Additional Resources

Resources for the Stingray are posted to the Stingray product page on our website. Go to our website at www.parallax.com and type the product number (28980) into the search box and click the Go button. Over time additional resources, videos, and accessories will be added so check back often as these will be linked from the Stingray product web page.

Tech Support Resources

Parallax Inc. offers several options for obtaining technical support for your product:

- Email: support@parallax.com
- Fax: (916) 624-8003
- Phone: (916) 624-8333 or toll-free in the U.S. at (888) 99-STAMP. Phone support is available Monday through Friday from 7:00 AM to 5:00 PM Pacific time or you can leave a message and a tech support representative will return your call as soon as possible.
- Forums: <http://forums.parallax.com>. Our support forums are available 24 hours a day, 7 days a week and are frequented by both Parallax customers and employees. You can often find fast answers to questions by searching previous posts or posting your questions.

Revision History

Version 2.0: The product documentation for this stock code was revised to support the Stingray Chassis Kit (which has no control board or power supply), replacing the Stingray Robot Kit after the Parallax Robot Control Board was discontinued.

Mouser Electronics

Authorized Distributor

Click to View Pricing, Inventory, Delivery & Lifecycle Information:

[Parallax:](#)

[28980](#)