

MAS6011

This is advance information on a new product under development. Micro Analog Systems Oy reserves the right to make any changes without notice.

*Advance
Information*

Solar Cell System Manager

- Power Down Indicator
- Low Battery Indicator
- Battery Overcharging Protection

DESCRIPTION

MAS6011 solar cell system manager monitors the supply voltage of a battery-powered system containing solar cells. Current consumption of this IC is extremely low. The solar manager uses three output signals to indicate the state of the system. Power Down (XPD) indicates whether the supply

voltage is high enough to run the system. Low Battery (LB) is used to signal the situation where the battery is low. The third signal, SOL, is used for battery charging control. When the battery is full it bypasses the charging current by an internal switch to avoid overcharging of the battery.

FEATURES

- Power Down Indicator
- Low Battery Indicator
- Battery Overcharging Protection
- Suitable for VL-type Rechargeable Lithium Batteries

APPLICATIONS

- Solar Powered Watch
- Solar Powered Equipment

BLOCK DIAGRAM

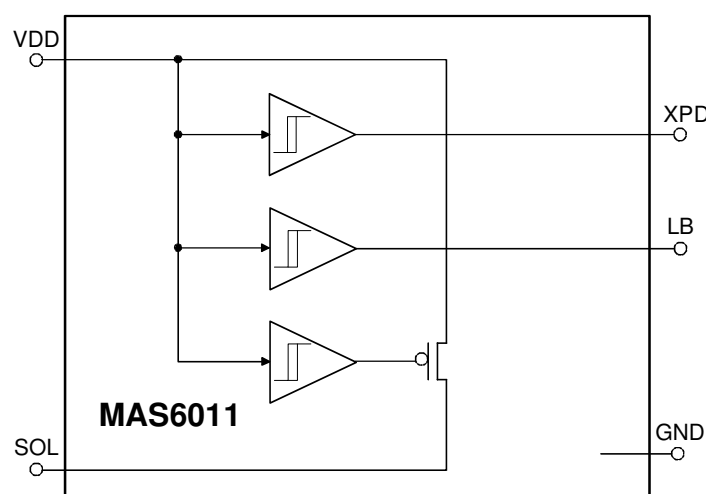

PAD LAYOUT: MAS6011AA3

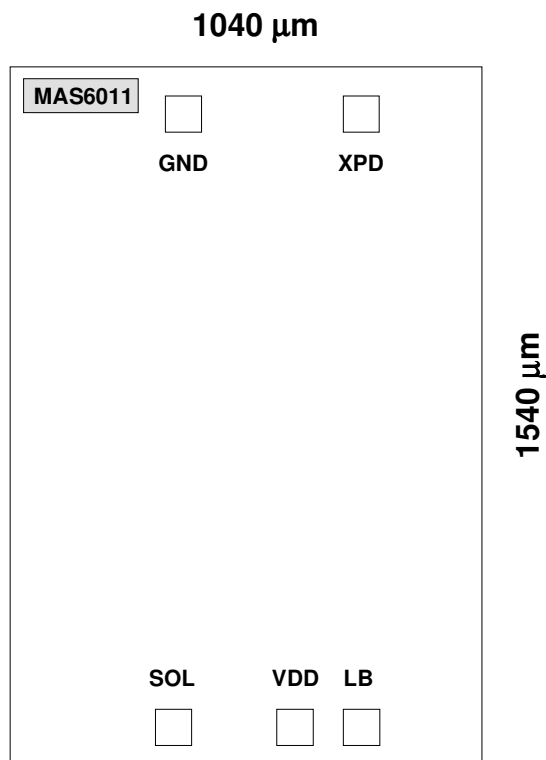

DIE size = 1040 μm x 1540 μm
PAD size = 80 x 80 μm

Note: This is a CMOS device and therefore it should be handled carefully to avoid any damage by static voltages (ESD). Make sure that GND is the first pad to be bonded. Pick-and-place and all component assembly are recommended to be performed in ESD protected area.

Note: If the die is to be placed on metal plane, the metal plane should be connected to GND or left floating because the substrate of the die is internally connected to GND.

Note: Coordinates are pad center points where origin has been located in the center of the silicon die.

Pad Identification	Name	X-coordinate	Y-coordinate
Power Supply Ground	GND	-129 μm	563 μm
Power Down Output	XPD	253 μm	563 μm
Solar Charging Output	SOL	-167 μm	-563 μm
Power Supply Voltage	VDD	102 μm	-563 μm
Low Battery Output	LB	253 μm	-563 μm

FUNCTIONAL DESCRIPTION

The solar manager generates three signals: XPD (Power Down), LB (Low Battery) and SOL (Solar Charging).

These signals are produced by three comparators which have hysteresis build in. Each comparator compares supply voltage (VDD) to internal switching levels (see Electrical Characteristics on the next page). The current consumption of the comparators is extremely low. The electrical parameters are described more detailed in the Electrical Characteristics chapter.

XPD signal can be used to stop the whole system whenever the power supply level has dropped low enough. When the power supply voltage is too low the XPD goes low to signal the microcontroller to go to power down. When the power supply voltage is high enough the XPD goes high signaling power up situation.

In case of low power microcontroller (max current consumption about 150 μ A) the XPD pin can be used to feed supply voltage directly to the microcontroller by connecting XPD pin to the supply voltage pin of the microcontroller (see application figure 3).

LB signal indicates that the battery is low but not empty. LB goes high when power supply level is too

low and LB goes low when power supply level is high enough.

SOL is used for controlling the charging of the rechargeable battery. When power supply voltage goes high enough, the internal PMOS switch between VDD and SOL pins is switched on to shunt the solar cell charging current and to prevent battery overcharging. When the power supply voltage is not too high the internal PMOS switch is non-conductive.

In operation without an external Schottky diode between the pins SOL and GND, the voltage at pin SOL is clamped to about 700 mV below GND by an internal diode-connected PNP transistor.

MAS6011 does not have any control pin. After the power supply is connected the device is ready to be used.

Figure 1 illustrates MAS6011 functions and shows the comparator switching levels at both battery charging (rising VDD) and discharging (falling VDD) conditions. The XPD, LB and SOL switching levels have been designed for usage of VL-type rechargeable lithium batteries.

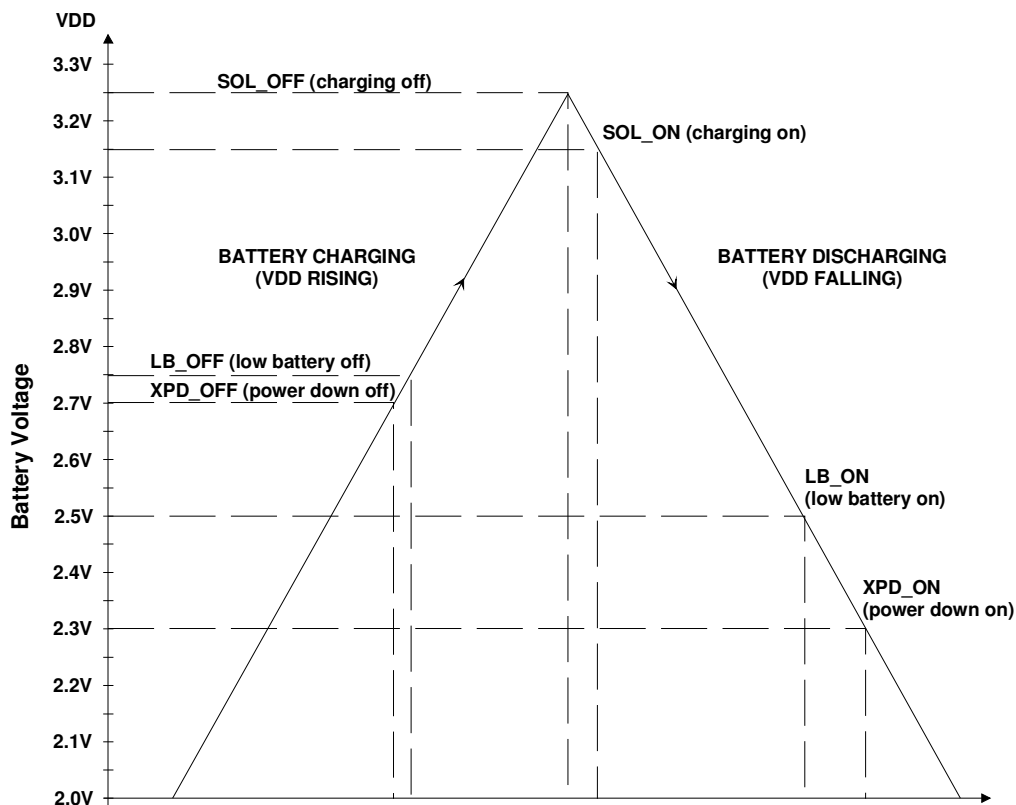

Figure 1. MAS6011 functions

ABSOLUTE MAXIMUM RATINGS

All voltages with respect to ground.

Parameter	Symbol	Conditions	Min	Max	Unit
Supply Voltage	VDD		-0.3	6.0	V
Voltage range for all pins			-0.3	VDD+0.3	V
Operating temperature	T _A		-20	+60	°C
Storage Temperature	T _S		-50	+125	°C

Stresses beyond those listed may cause permanent damage to the device. The device may not operate under these conditions, but it will not be destroyed.

This is a CMOS device and therefore it should be handled carefully to avoid any damage by static voltages (ESD).

ELECTRICAL CHARACTERISTICS: MAS6011AA3 (3V BATTERY, MCU VDD_{min} ≤ 2.1V)

 T_A = -20°C to +60°C, typical values at T_A = +27°C, unless otherwise specified.

Parameter	Symbol	Conditions	Min	Typ	Max	Unit
Supply voltage	VDD		2.0	3.0	3.6	V
Current consumption	I _Q			130		nA
XPD switching level	XPD_OFF XPD_ON	Power Down Off (XPD high) Power Down On (XPD low)	2.50 2.10	2.70 2.30	2.90 2.50	V
XPD hysteresis	V _{XPD(H)}		200	400		mV
XPD output voltage	V _{XPD(OUT)}	VDD = 2.1 V, I _{XPD} = -150 μA		2.0		V
LB switching level	LB_OFF LB_ON	Low Battery Off (LB low) Low Battery On (LB high)	2.60 2.35	2.75 2.50	2.90 2.65	V
LB hysteresis	V _{LB(H)}		100	250		mV
LB output voltage	V _{LB(OUT)}	VDD = 2.1 V, I _{LB} = -50 μA VDD = 3.0 V, I _{LB} = +50 μA		2.05 0.05		V
SOL switching level	SOL_OFF SOL_ON	Solar Charging Off Solar Charging On	3.05 2.85	3.25 3.15	3.55 3.45	V
SOL hysteresis	V _{SOL(H)}		50	100		mV
SOL sink current	I _{SOL}	VDD = 3.2 V, SOL = 0 V, SOL switch On		22		mA
SOL leakage current		VDD = 2.9 V	-50		50	nA
LB_OFF – XPD_OFF	V _{LB_XPD_OFF}			50		mV
LB_ON – XPD_ON	V _{LB_XPD_ON}		100	200	300	mV
SOL_OFF – LB_OFF	V _{SOL_LB_OFF}			500		mV
SOL_ON – LB_ON	V _{SOL_LB_ON}		350	650		mV

TBD = To be defined

TYPICAL APPLICATION

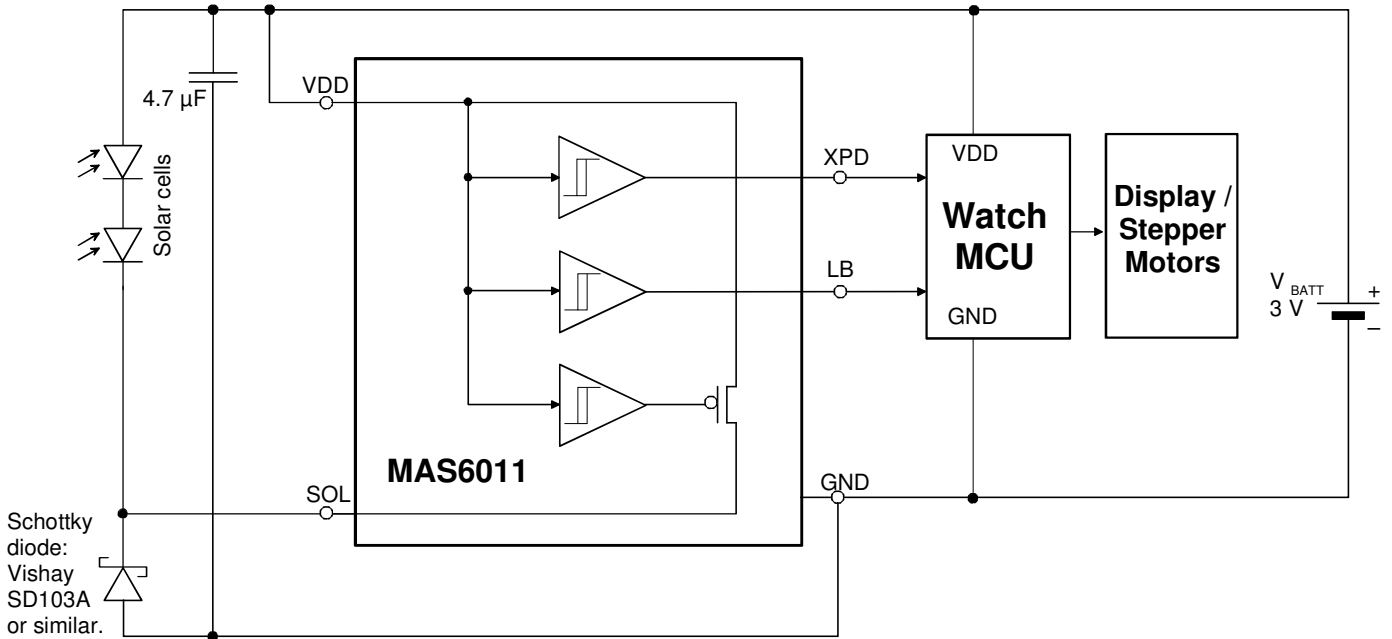

Figure 2. Typical application circuit of MAS6011AA3 – XPD as power on control signal for a microcontroller

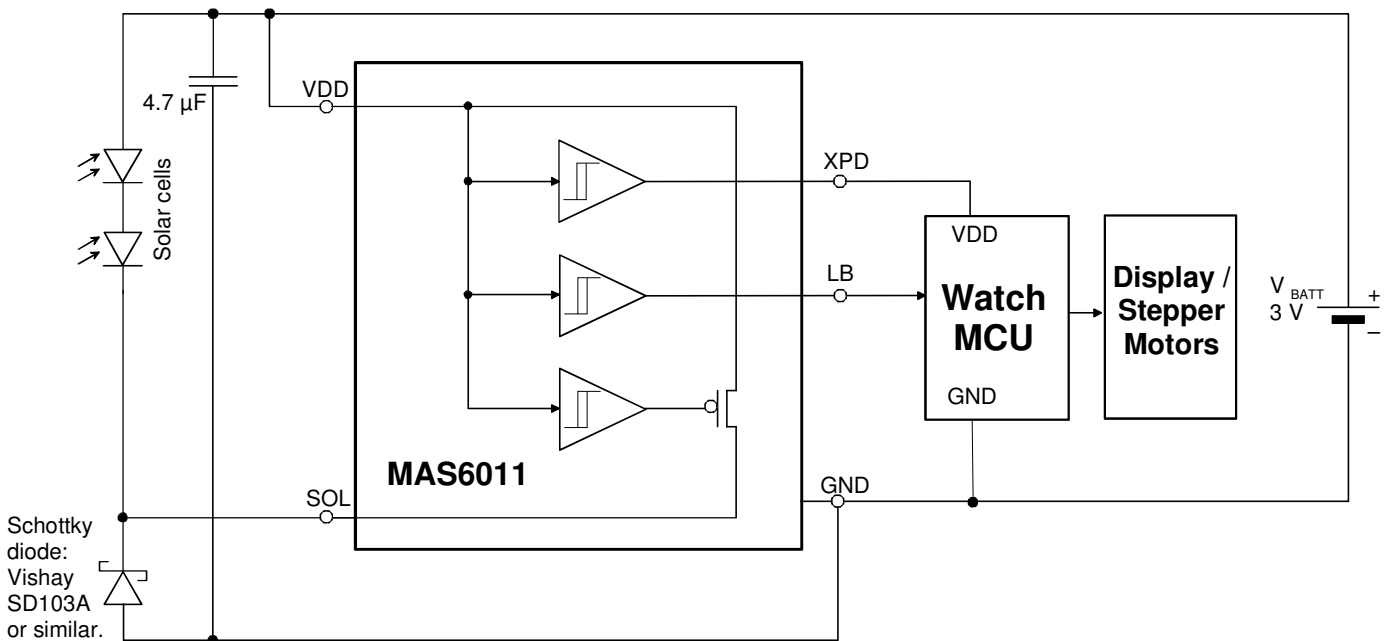
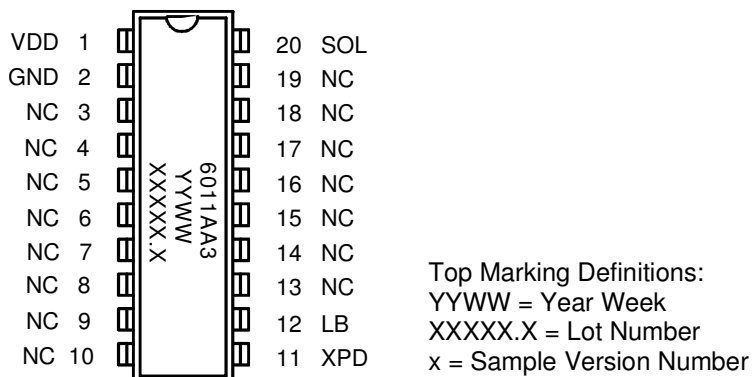

Figure 3. Typical application circuit of MAS6011AA3 – XPD as supply voltage for a low power microcontroller

MAS6011AA3 SAMPLES IN SBDIL 20 PACKAGE



SBDIL 20 PIN DESCRIPTION

Pin Name	Pin	Type	Function
VDD	1	P	Positive Power Supply
GND	2	G	Power Supply Ground
NC	3, 4, 5, 6, 7, 8, 9, 10		
XPD	11	DO	Power Down Output
LB	12	DO	Low Battery Output
NC	13, 14, 15, 16, 17, 18, 19		
SOL	20	AO	Solar Charging Output

NC = Not Connected, P = Power, G = Ground, DO = Digital Output, AO = Analog Output

MAS6011AA3 IN QFN 3x3 PACKAGE

QFN 3x3 6ld

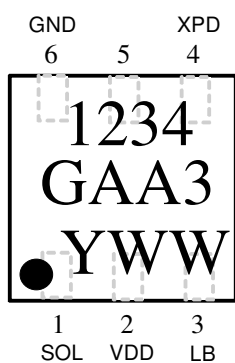

Top Marking Information: 1234 = Product Number, AA3 = Version Number
G = Lead Free, RoHS Compliant Package, YWW = Year Week

QFN 3x3 PIN DESCRIPTION

Pin Name	Pin	Type	Function
SOL	1	AO	Solar Charging Output
VDD	2	P	Positive Power Supply
LB	3	DO	Low Battery Output
XPB	4	DO	Power Down Output
	5	NC	
GND	6	G	Power Supply Ground

NC = Not Connected, P = Power, G = Ground, DO = Digital Output, AO = Analog Output

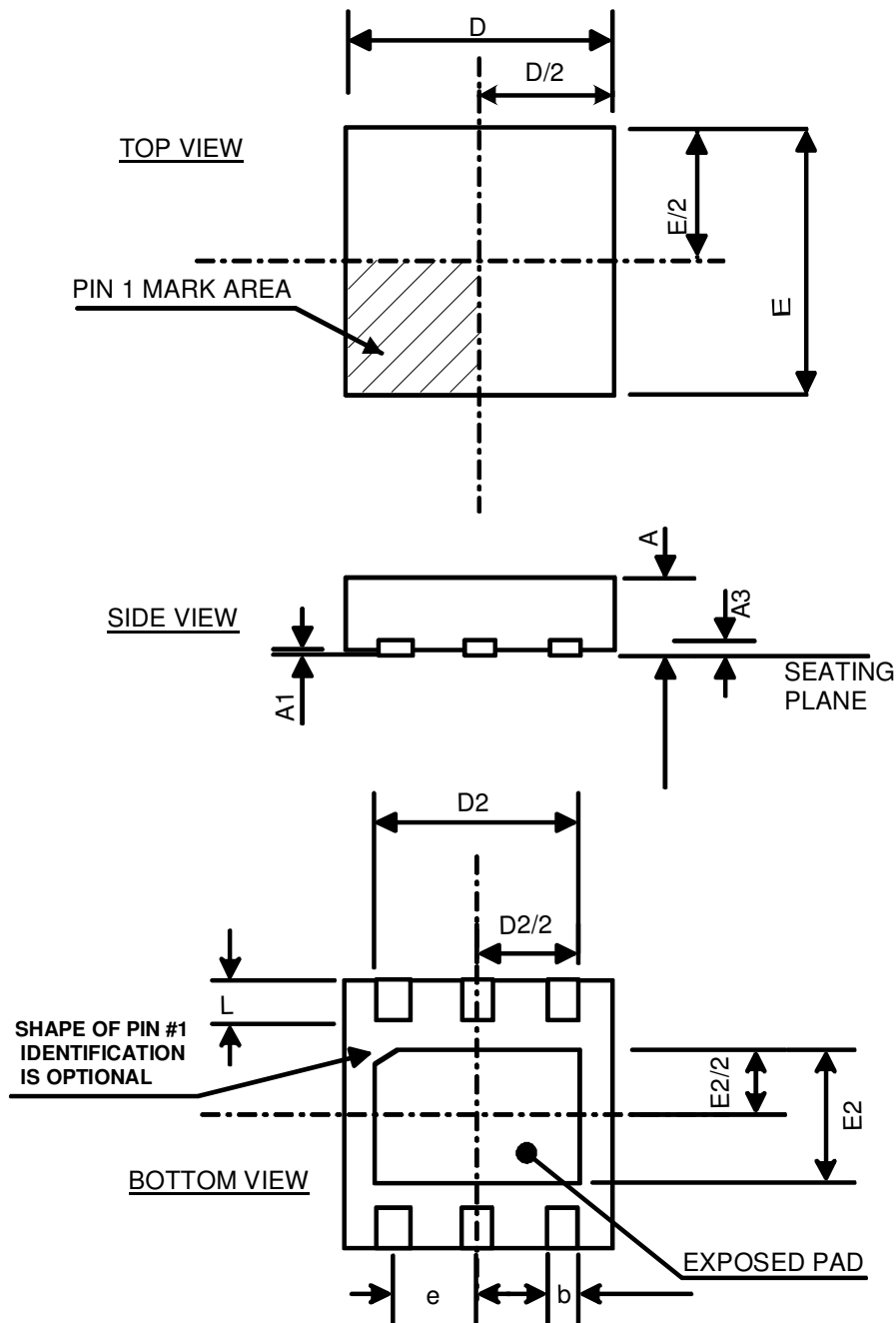
PACKAGE (QFN 3X3x0.75 6ld) OUTLINE

Symbol	Min	Nom	Max	Unit
PACKAGE DIMENSIONS				
A	0.70	0.75	0.80	mm
A1	0.0	0.02	0.05	mm
A3	0.178	0.203	0.228	mm
b	0.350	0.400	0.450	mm
D		3.00 BSC		mm
D2 (Exposed pad)	2.25	2.3	2.35	mm
E		3.00 BSC		mm
E2 (Exposed pad)	1.45	1.5	1.55	mm
e		0.95 BSC		mm
L	0.425	0.475	0.525	mm

Dimensions do not include mold or interlead flash, protrusions or gate burrs.

ORDERING INFORMATION

Product Code	Product	Package	Comments
MAS6011AA3WA300	Solar Cell System Manager (for 3 V rechargeable battery)	Tested wafer, thickness 400 μ m	
MAS6011AA3Q1306	Solar Cell System Manager (for 3 V rechargeable battery)	QFN 3x3x0.75mm Pb-free RoHS compliant	Tape and Reel

Please contact Micro Analog Systems Oy for 1.5 V rechargeable battery voltage version.

LOCAL DISTRIBUTOR

--

MICRO ANALOG SYSTEMS OY CONTACTS

Micro Analog Systems Oy Kamreerintie 2, P.O.Box 51 FIN-02771 Espoo, FINLAND http://www.mas-oy.com	Tel. (09) 80 521 Tel. Int. +358 9 80 521 Telefax +358 9 805 3213 E-mail: info@mas-oy.com
--	--