

Infrared Light Emitting Diode in SMD Plastic Package

OP270 Series

- 890nm Wavelength
- Narrow Beam Angle
- High Power
- 1.9mm Water Clear Plastic Package
- Four Lead Configurations

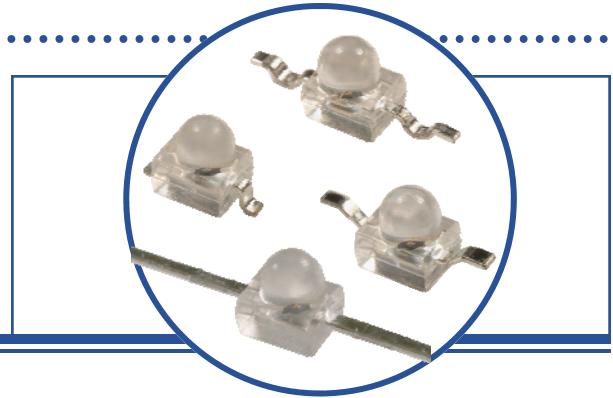

Description:

The OP270 series are GaAlAs infrared LEDs mounted in a clear plastic SMT packages. The devices incorporate an integral molded lens which enables a narrow beam angle and provides an even emission pattern. This series is available with four lead configurations and is compatible with most automated mounting equipment. The OP270 Series LEDs are mechanically and spectrally matched to the OP570 series phototransistors.

Applications

- Non-Contact Position Sensing
- Datum detection
- Machine automation
- Optical encoders
- IrDA
- Reflective and Transmissive Sensors

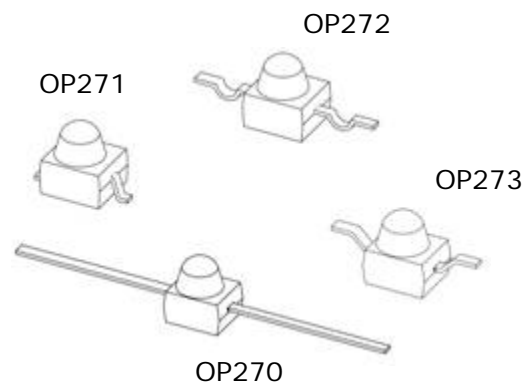
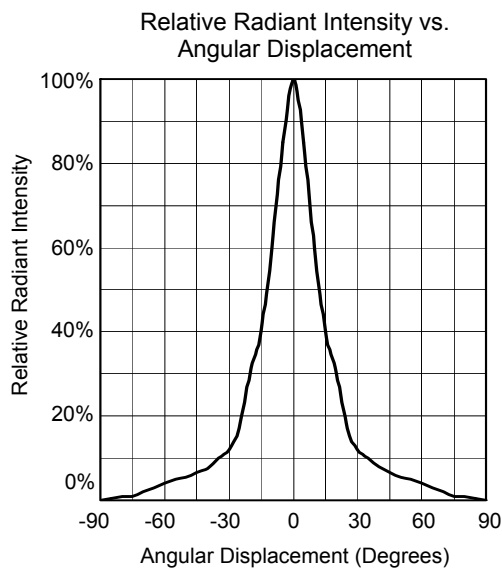

RoHS

Optek reserves the right to make changes at any time in order to improve design and to supply the best product possible.

OPTEK Technology Inc.— 1645 Wallace Drive, Carrollton, Texas 75006
Phone: (800) 341-4747 FAX: (972) 323- 2396 sensors@optekinc.com www.optekinc.com



A subsidiary of
TT electronics plc

SMD Infrared LED

OP270 Series



Absolute Maximum Ratings ($T_A = 25^\circ\text{C}$ unless otherwise noted)

PARAMETER	SYMBOL	MAXIMUM	UNITS
Continuous Forward Current	I_F	50	mA
Power Dissipation	P_d	130	mW
Reverse Voltage	I_R	2	V
Peak Forward Current (1 μs pulse width, 300 pps)	I_{FP}	1	A
Lead Soldering Temperature (1.6mm to epoxy for 5 sec.)	T_{SOL}	260°	C
Operating Temperature Range	T_{OPR}	-40°C to +85°C	
Storage Temperature Range	T_{STG}	-40°C to +100°C	

Notes:

- Solder time less than 5 seconds at temperature extreme.
- De-rate linearly at 2.17 mW/°C above 25° C.

Electrical Characteristics ($T_A = 25^\circ\text{C}$ unless otherwise noted)

SYMBOL	PARAMETER	MIN	TYP	MAX	UNITS	CONDITIONS
$E_{e(APT)}$	Apertured Radiant Incidence	1.5			mW/cm ²	$I_F = 20\text{mA}^{(3)}$
V_F	Forward Voltage			1.5	V	$I_F = 20\text{mA}$
I_R	Reverse Current			100	μA	$V_R = 2.0\text{V}$
λ_P	Peak Emission Wavelength		890		nm	$I_F = 10\text{mA}$
Θ_{HP}	Emission Angle at Half Power Points		25		Deg.	$I_F = 20\text{mA}$
t_r, t_f	Rise and Fall Time			500	ns	$I_{F(PEAK)} = 100\text{mA}$, PW = 10 μs , 10% D.C.

- $E_{e(APT)}$ is a measurement of the apertured radiant incidence upon a sensing area 0.081" (2.06mm) in diameter, perpendicular to and centered on the mechanical axis of the lens, and 0.590" (14.99mm) from the measurement surface. $E_{e(APT)}$ is not necessarily uniform within the measured area.

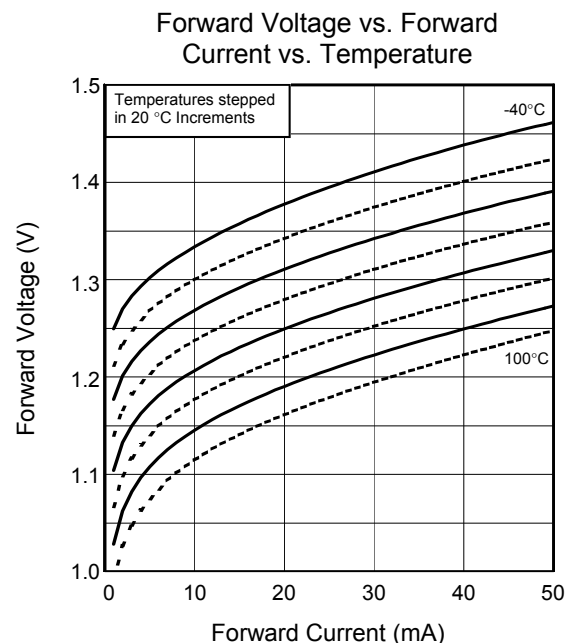
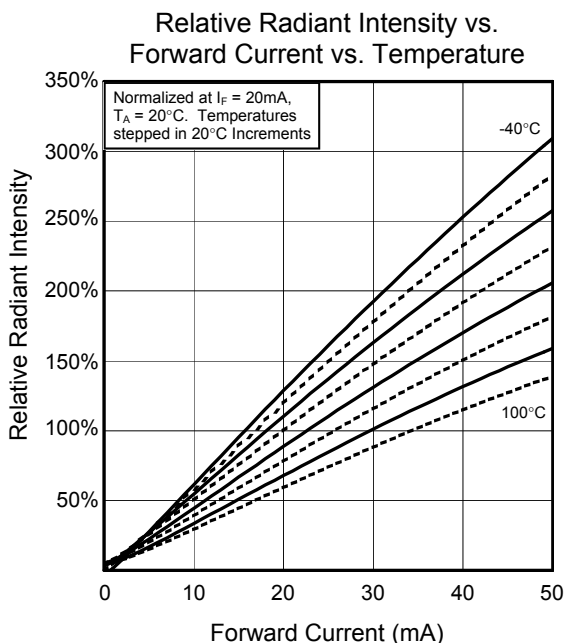

SMD Infrared LED

OP270 Series



OP270

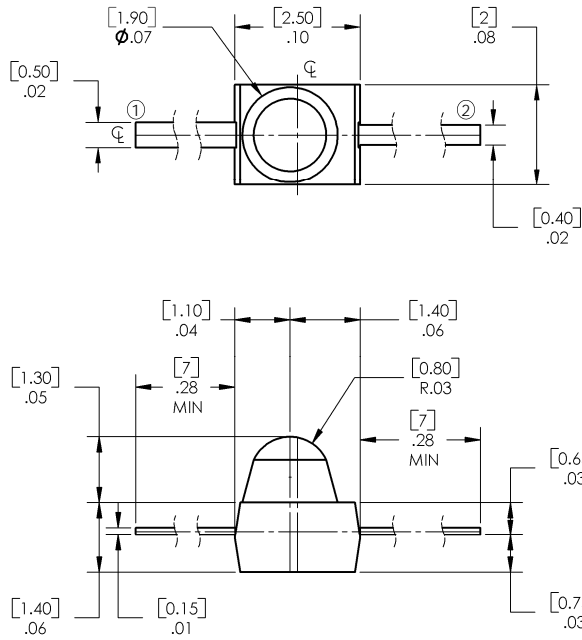

DIMENSIONS ARE IN INCHES AND [MILLIMETERS].
TOLERANCE IS $\pm .0039$ [0.1]

PIN	LED
1	A
2	K

OP271

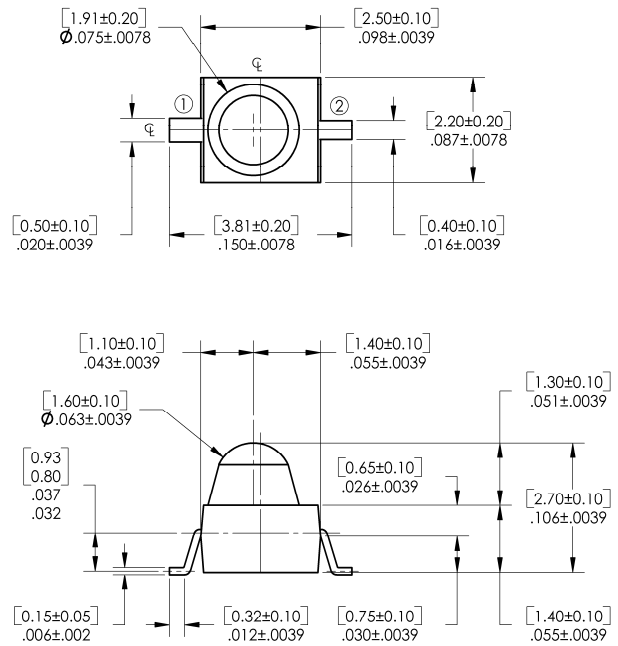

DIMENSIONS ARE IN INCHES AND [MILLIMETERS].

PIN	LED
1	A
2	K

OP272

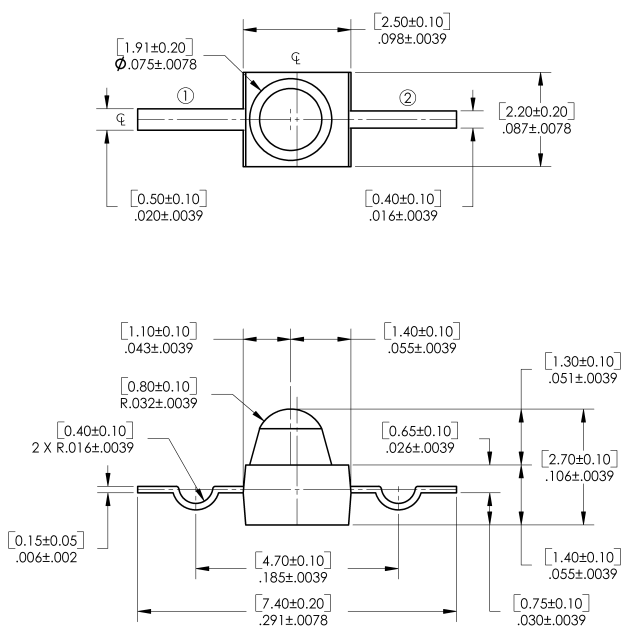

DIMENSIONS ARE IN INCHES AND [MILLIMETERS].

PIN	LED
1	A
2	K

OP273

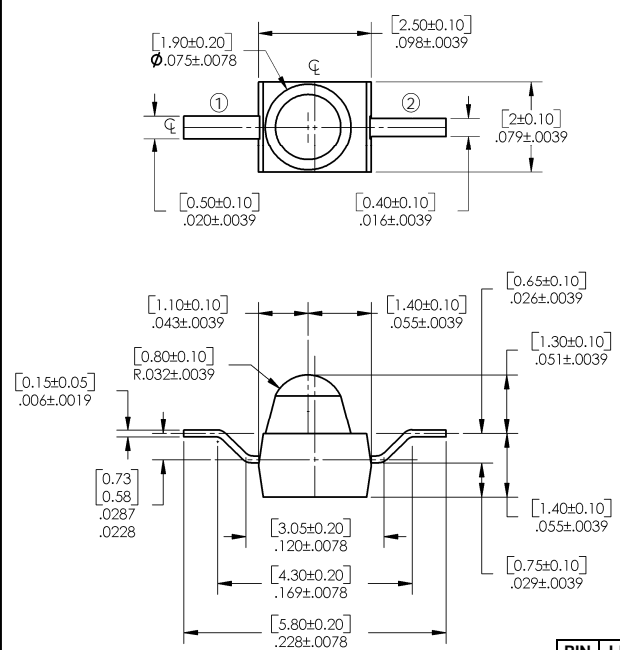

DIMENSIONS ARE IN INCHES AND [MILLIMETERS].

PIN	LED
1	A
2	K