

# ELECTRIC DOUBLE LAYER CAPACITORS "EVerCAP®"

nichicon

NEW

JL series Screw Terminal Type, High Power Density Type

- High power density.
- Rapid charge-discharge.
- Suitable for regeneration and UPS applications.
- Adapted to the RoHS directive (2002/95/EC).

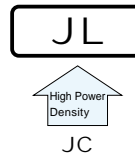

## Specifications

Item	Performance Characteristics					
Category Temperature Range	- 25 ~ + 60°C					
Rated Voltage Range	2.5V					
Rated Capacitance Range	400 ~ 2600F See Note					
Capacitance Tolerance	±20% (20°C)					
Stability at Low Temperature	Capacitance (-25°C) / Capacitance (+20°C) ×100 ≥ 70% DCR (-25°C) / DCR (+20°C) ≤ 7					
DCR*	Refer to the list below. (20°C) *DC internal resistance					
Endurance	After an application of DC voltage for 2000 hours at 60°C, capacitors meet the characteristic requirements listed at right.	<table border="1"> <tr> <td>Capacitance change</td> <td>Within ±30% of initial value</td> </tr> <tr> <td>DCR</td> <td>300% or less of initial specified value</td> </tr> </table>	Capacitance change	Within ±30% of initial value	DCR	300% or less of initial specified value
	Capacitance change	Within ±30% of initial value				
DCR	300% or less of initial specified value					
Shelf Life	After storing the capacitors under no load at 60°C for 2000 hours, they will meet the characteristic requirements listed at right.	<table border="1"> <tr> <td>Capacitance change</td> <td>Within ±30% of initial value</td> </tr> <tr> <td>DCR</td> <td>300% or less of initial specified value</td> </tr> </table>	Capacitance change	Within ±30% of initial value	DCR	300% or less of initial specified value
	Capacitance change	Within ±30% of initial value				
DCR	300% or less of initial specified value					
Marking	Printed with white color letter on black sleeve.					

## Drawing

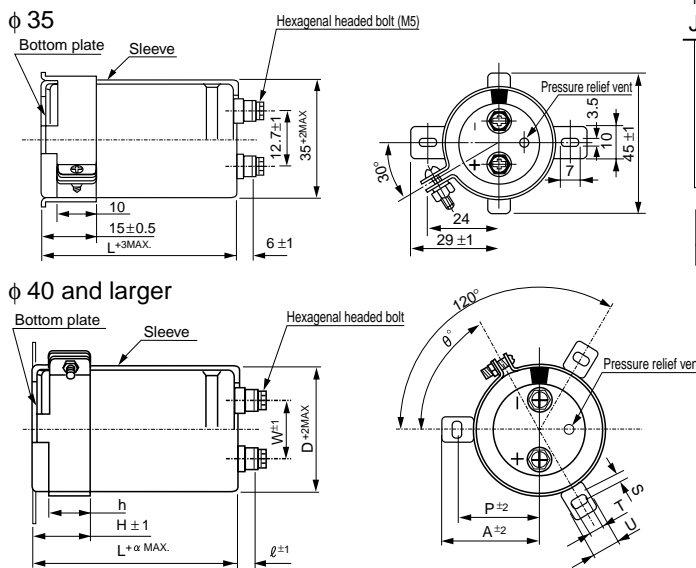

## Type numbering system (Example : 2.5V 400F)

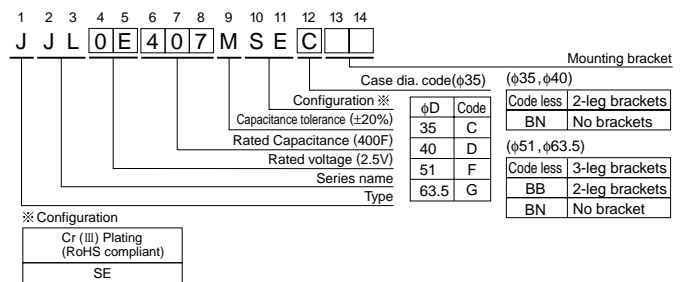

## Dimensions

Rated Voltage (Code)	Cap. (F)	Cap. code	DCR (mΩ)	Case size φD × L (mm)		Weight (g)
				φ D	L	
2.5V (0E)	400	407	7	35	85	130
	550	557	5		105	160
	650	657	4		135	210
	700	707	4	40	105	210
	850	857	3		135	250
	1500	158	2	51	135	450
	1600	168	2		150	500
	2600	268	1	63.5	150	800

## Dimensions of terminal pitch(W) and length(ℓ) and Normal dia. of bolt (mm)

φ D	W	ℓ	α	Nominal of bolt
40	18.8	9	3	M6
51	22.0	10	3	M6
63.5	28.6	10	3	M6

## Dimensions of mounting bracket (mm)

Leg shape Symbol	3-Legs			2-Legs	
	51	63.5	40	51	63.5
P	32.5	38.1	27	33.2	40.5
A	38.5	43	32	40	46.5
T	7.5	8.0	7.0	6.0	7.0
S	5.0	5.0	3.5	4.5	4.5
U	12	14	10	14	14
θ°	60	60	45	30	30
H	20	25	17	25	35
h	15	20	12	15	20

## Note :

To calculate capacitance, the capacitor must be charged at the rated voltage of 2.5V for 30 minutes. Measure the time of duration ΔT (sec.) it takes go from 2V to 1V when a constant current discharge of i (A) = 0.01 × nominal capacitance is carried out. It is then possible to calculate capacitance based on the calculation provided below.

$$\text{Capacitance (F)} = I \times \Delta T$$

CAT.8100V