

# AZ10LVE111E AZ100LVE111E

## ECL/PECL 1:9 Differential Clock Driver with Enable

---

### FEATURES

- Operating Range of 3.0V to 5.5V
- Low Skew
- Guaranteed Skew Spec
- Differential Design
- Enable
- $V_{BB}$  Output
- 75k $\Omega$  Internal Input Pulldown Resistors
- Direct Replacement for ON Semiconductor MC10E111 & MC100E111

### PACKAGE AVAILABILITY

PACKAGE	PART NO.	MARKING	NOTES
PLCC 28	AZ10LVE111EFN	AZ10 LVE111E <Date Code>	1,2
PLCC 28	AZ100LVE111EFN	AZ100 LVE111E <Date Code>	1,2

- 1 Add R2 at end of part number for 13 inch (750 parts) Tape & Reel.  
2 Date code format: "YY" for year followed by "WW" for week.

### DESCRIPTION

The AZ10/100LVE111E is a low skew 1-to-9 differential driver, designed with clock distribution in mind. The IN signal is fanned-out to nine identical differential outputs. An Enable input is also provided. A HIGH disables the device by forcing all Q outputs LOW and all  $\bar{Q}$  outputs HIGH.

The AZ100LVE111E provides a  $V_{BB}$  output for single-ended use or a DC bias reference for AC coupling to the device. For single-ended input applications, the  $V_{BB}$  reference should be connected to one side of the IN/ $\bar{IN}$  differential input pair. The input signal is then fed to the other IN/ $\bar{IN}$  input. The  $V_{BB}$  pin should be used only as a bias for the AZ100LVE111E as its current sink/source capability is limited. When used, the  $V_{BB}$  pin should be bypassed to ground via a 0.01 $\mu$ F capacitor.

The device is specifically designed, modeled and produced with low skew as the key goal. Optimal design and layout serve to minimize gate-to-gate within-device skew, and empirical modeling is used to determine process control limits that ensure consistent  $t_{pd}$  distributions from lot-to-lot. The net result is a dependable, guaranteed low skew device.

To ensure that the tight skew specification is met, both sides of the differential output must be terminated into 50 $\Omega$ , even if only one side is used. In most applications all nine differential pairs will be used and therefore terminated. In the case where fewer than nine pairs are used, it is necessary to terminate at least the output pairs on the same package side (i.e. sharing the same  $V_{CC0}$ ) as the pair(s) being used on that side, in order to maintain minimum skew. Failure to do this will result in small degradations of propagation delay (on the order of 10-20ps) of the output(s) being used that, while not being catastrophic to most designs, will mean a loss of skew margin.

NOTE: Specifications in the ECL/PECL tables are valid when thermal equilibrium is established.

# AZ10LVE111E AZ100LVE111E

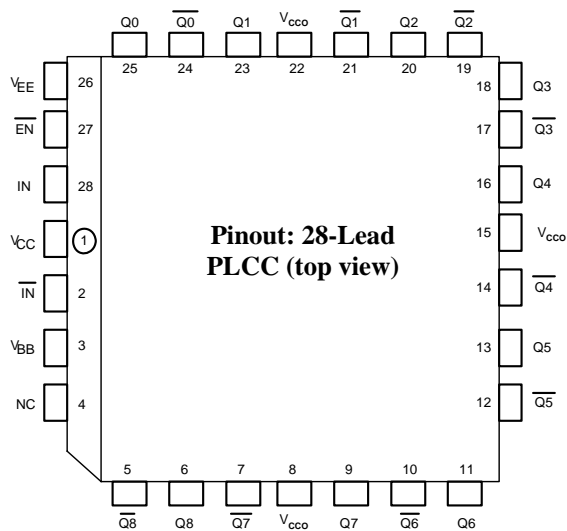

## PIN DESCRIPTION

PIN	FUNCTION
IN, $\overline{\text{IN}}$	Differential Input Pair
EN	Enable
Q0, $\overline{\text{Q0}}$ - Q8, $\overline{\text{Q8}}$	Differential Outputs
V <sub>BB</sub>	V <sub>BB</sub> Output
V <sub>CC</sub> , V <sub>CCO</sub>	Positive Supply
V <sub>EE</sub>	Negative Supply
NC	No Connect

## LOGIC SYMBOL

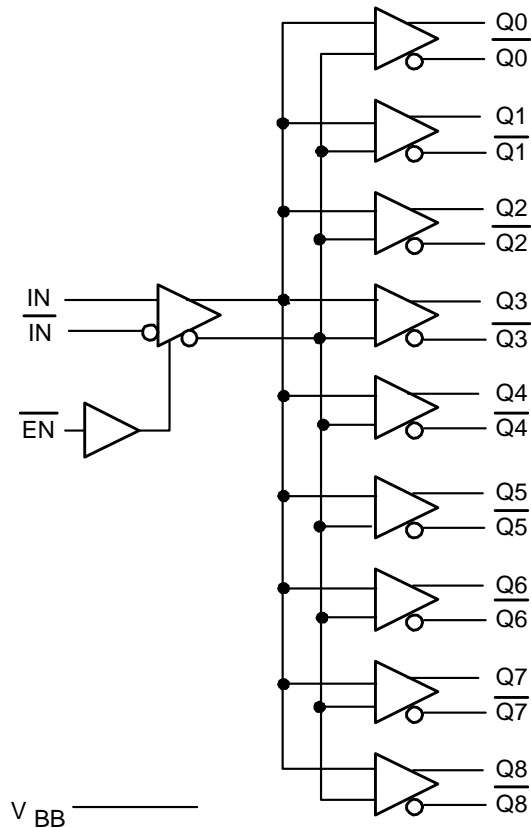

**Absolute Maximum Ratings are those values beyond which device life may be impaired.**

Symbol	Characteristic	Rating	Unit
V <sub>CC</sub>	PECL Power Supply (V <sub>EE</sub> = 0V)	0 to +8.0	Vdc
V <sub>I</sub>	PECL Input Voltage (V <sub>EE</sub> = 0V)	0 to +6.0	Vdc
V <sub>EE</sub>	ECL Power Supply (V <sub>CC</sub> = 0V)	-8.0 to 0	Vdc
V <sub>I</sub>	ECL Input Voltage (V <sub>CC</sub> = 0V)	-6.0 to 0	Vdc
I <sub>OUT</sub>	Output Current --- Continuous --- Surge	50 100	mA
T <sub>A</sub>	Operating Temperature Range	-40 to +85	°C
T <sub>STG</sub>	Storage Temperature Range	-65 to +150	°C

## 10K ECL DC Characteristics (V<sub>EE</sub> = -3.0V to -5.5V, V<sub>CC</sub> = V<sub>CCO</sub> = GND)

Symbol	Characteristic	-40°C			0°C			25°C			85°C			Unit
		Min	Typ	Max	Min	Typ	Max	Min	Typ	Max	Min	Typ	Max	
V <sub>OH</sub>	Output HIGH Voltage <sup>1</sup>	-1080		-890	-1020		-840	-980		-810	-910		-720	mV
V <sub>OL</sub>	Output LOW Voltage <sup>1</sup>	-1950		-1650	-1950		-1630	-1950		-1630	-1950		-1595	mV
V <sub>IH</sub>	Input HIGH Voltage	-1230		-890	-1170		-840	-1130		-810	-1060		-720	mV
V <sub>IL</sub>	Input LOW Voltage	-1950		-1500	-1950		-1480	-1950		-1480	-1950		-1445	mV
V <sub>BB</sub>	Reference Voltage	-1430		-1300	-1380		-1270	-1350		-1250	-1310		-1190	mV
I <sub>IH</sub>	Input HIGH Current			150			150			150			150	μA
I <sub>IL</sub>	Input LOW Current	0.5			0.5			0.5			0.5			μA
I <sub>EE</sub>	Power Supply Current		48	60		48	60		48	60		48	60	mA

1. Each output is terminated through a 50Ω resistor to V<sub>CC</sub> - 2V.

**AZ10LVE111E**  
**AZ100LVE111E**

**10K LVPECL DC Characteristics** ( $V_{EE} = \text{GND}$ ,  $V_{CC} = V_{CCO} = +3.3\text{V}$ )

Symbol	Characteristic	-40°C			0°C			25°C			85°C			Unit
		Min	Typ	Max	Min	Typ	Max	Min	Typ	Max	Min	Typ	Max	
V <sub>OH</sub>	Output HIGH Voltage <sup>1,2</sup>	2220		2410	2280		2460	2320		2490	2390		2580	mV
V <sub>OL</sub>	Output LOW Voltage <sup>1,2</sup>	1350		1650	1350		1670	1350		1670	1350		1705	mV
V <sub>IH</sub>	Input HIGH Voltage <sup>1</sup>	2070		2410	2130		2460	2170		2490	2240		2580	mV
V <sub>IL</sub>	Input LOW Voltage <sup>1</sup>	1350		1800	1350		1820	1350		1820	1350		1855	mV
V <sub>BB</sub>	Reference Voltage <sup>1</sup>	1870		2000	1920		2030	1950		2050	1990		2110	mV
I <sub>IH</sub>	Input HIGH Current			150			150			150			150	μA
I <sub>IL</sub>	Input LOW Current	0.5			0.5			0.5			0.3			μA
I <sub>EE</sub>	Power Supply Current		48	60		48	60		48	60		48	60	mA

- For supply voltages other than 3.3V, use the ECL table values and ADD supply voltage value.
- Each output is terminated through a 50Ω resistor to V<sub>CC</sub> - 2V.

**10K PECL DC Characteristics** ( $V_{EE} = \text{GND}$ ,  $V_{CC} = V_{CCO} = +5.0\text{V}$ )

Symbol	Characteristic	-40°C			0°C			25°C			85°C			Unit
		Min	Typ	Max	Min	Typ	Max	Min	Typ	Max	Min	Typ	Max	
V <sub>OH</sub>	Output HIGH Voltage <sup>1,2</sup>	3920		4110	3980		4160	4020		4190	4090		4280	mV
V <sub>OL</sub>	Output LOW Voltage <sup>1,2</sup>	3050		3350	3050		3370	3050		3370	3050		3405	mV
V <sub>IH</sub>	Input HIGH Voltage <sup>1</sup>	3770		4110	3830		4160	3870		4190	3940		4280	mV
V <sub>IL</sub>	Input LOW Voltage <sup>1</sup>	3050		3500	3050		3520	3050		3520	3050		3555	mV
V <sub>BB</sub>	Reference Voltage <sup>1</sup>	3570		3700	3620		3730	3650		3750	3690		3810	mV
I <sub>IH</sub>	Input HIGH Current			150			150			150			150	μA
I <sub>IL</sub>	Input LOW Current	0.5			0.5			0.5			0.3			μA
I <sub>EE</sub>	Power Supply Current		48	60		48	60		48	60		48	60	mA

- For supply voltages other than 5.0V, use the ECL table values and ADD supply voltage value.
- Each output is terminated through a 50Ω resistor to V<sub>CC</sub> - 2V.

**100K ECL DC Characteristics** ( $V_{EE} = -3.0\text{V}$  to  $-5.5\text{V}$ ,  $V_{CC} = V_{CCO} = \text{GND}$ )

Symbol	Characteristic	-40°C			0°C			25°C			85°C			Unit
		Min	Typ	Max	Min	Typ	Max	Min	Typ	Max	Min	Typ	Max	
V <sub>OH</sub>	Output HIGH Voltage <sup>1</sup>	-1085	-1005	-880	-1025	-955	-880	-1025	-955	-880	-1025	-955	-880	mV
V <sub>OL</sub>	Output LOW Voltage <sup>1</sup>	-1830	-1695	-1555	-1810	-1705	-1620	-1810	-1705	-1620	-1810	-1705	-1620	mV
V <sub>IH</sub>	Input HIGH Voltage	-1165		-880	-1165		-880	-1165		-880	-1165		-880	mV
V <sub>IL</sub>	Input LOW Voltage	-1810		-1475	-1810		-1475	-1810		-1475	-1810		-1475	mV
V <sub>BB</sub>	Reference Voltage	-1380		-1260	-1380		-1260	-1380		-1260	-1380		-1260	mV
I <sub>IH</sub>	Input HIGH Current			150			150			150			150	μA
I <sub>IL</sub>	Input LOW Current	0.5			0.5			0.5			0.5			μA
I <sub>EE</sub>	Power Supply Current		48	60		48	60		48	60		55	69	mA

- Each output is terminated through a 50Ω resistor to V<sub>CC</sub> - 2V.

**100K LVPECL DC Characteristics** ( $V_{EE} = \text{GND}$ ,  $V_{CC} = V_{CCO} = +3.3\text{V}$ )

Symbol	Characteristic	-40°C			0°C			25°C			85°C			Unit
		Min	Typ	Max	Min	Typ	Max	Min	Typ	Max	Min	Typ	Max	
V <sub>OH</sub>	Output HIGH Voltage <sup>1,2</sup>	2215	2295	2420	2275	2345	2420	2275	2345	2420	2275	2345	2420	mV
V <sub>OL</sub>	Output LOW Voltage <sup>1,2</sup>	1470	1605	1745	1490	1595	1680	1490	1595	1680	1490	1595	1680	mV
V <sub>IH</sub>	Input HIGH Voltage <sup>1</sup>	2135		2420	2135		2420	2135		2420	2135		2420	mV
V <sub>IL</sub>	Input LOW Voltage <sup>1</sup>	1490		1825	1490		1825	1490		1825	1490		1825	mV
V <sub>BB</sub>	Reference Voltage <sup>1</sup>	1920		2040	1920		2040	1920		2040	1920		2040	mV
I <sub>IH</sub>	Input HIGH Current			150			150			150			150	μA
I <sub>IL</sub>	Input LOW Current	0.5			0.5			0.5			0.5			μA
I <sub>EE</sub>	Power Supply Current		48	60		48	60		48	60		55	69	mA

- For supply voltages other than 3.3V, use the ECL table values and ADD supply voltage value.
- Each output is terminated through a 50Ω resistor to V<sub>CC</sub> - 2V.

# AZ10LVE111E

## AZ100LVE111E

### 100K PECL DC Characteristics ( $V_{EE} = \text{GND}$ , $V_{CC} = V_{CC0} = +5.0\text{V}$ )

Symbol	Characteristic	-40°C			0°C			25°C			85°C			Unit
		Min	Typ	Max	Min	Typ	Max	Min	Typ	Max	Min	Typ	Max	
$V_{OH}$	Output HIGH Voltage <sup>1,2</sup>	3915	3995	4120	3975	4045	4120	3975	4045	4120	3975	4045	4120	mV
$V_{OL}$	Output LOW Voltage <sup>1,2</sup>	3170	3305	3445	3190	3295	3380	3190	3295	3380	3190	3295	3380	mV
$V_{IH}$	Input HIGH Voltage <sup>1</sup>	3835		4120	3835		4120	3835		4120	3835		4120	mV
$V_{IL}$	Input LOW Voltage <sup>1</sup>	3190		3525	3190		3525	3190		3525	3190		3525	mV
$V_{BB}$	Reference Voltage <sup>1</sup>	3620		3740	3620		3740	3620		3740	3620		3740	mV
$I_{IH}$	Input HIGH Current			150			150			150			150	$\mu\text{A}$
$I_{IL}$	Input LOW Current	0.5			0.5			0.5			0.5			$\mu\text{A}$
$I_{EE}$	Power Supply Current		48	60		48	60		48	60		55	69	mA

- For supply voltages other than 5.0V, use the ECL table values and ADD supply voltage value.
- Each output is terminated through a 50 $\Omega$  resistor to  $V_{CC} - 2\text{V}$ .

### AC Characteristics ( $V_{EE} = -3.0\text{V}$ to $-5.5\text{V}$ , $V_{CC} = V_{CC0} = \text{GND}$ or $V_{EE} = \text{GND}$ , $V_{CC} = V_{CC0} = +3.0$ to $+5.5\text{V}$ )

Symbol	Characteristic	-40°C			0°C			25°C			85°C			Unit	
		Min	Typ	Max	Min	Typ	Max	Min	Typ	Max	Min	Typ	Max		
$t_{PLH} / t_{PHL}$	Propagation Delay to Output	IN (Diff) <sup>1</sup>	380		650	460		560	480		580	510		610	ps
		IN (SE) <sup>2</sup>	280		700	410		610	430		630	460		660	
		Enable <sup>3</sup>	400		900	450		850	450		850	450		850	
		Disable <sup>3</sup>	400		900	450		850	450		850	450		850	
$t_S$	Setup Time	EN to IN <sup>5</sup>	250	0		200	0		200	0		200	0	ps	
$t_H$	Hold Time	IN to EN <sup>6</sup>	50	-200		0	-200		0	-200		0	-200	ps	
$t_R$	Release Time	EN to IN <sup>7</sup>	350	100		300	100		300	100		300	100	ps	
$t_{skew}$	Within-Device Skew <sup>4</sup>			25	75		25	50		25	50		25	50	ps
$V_{PP}(\text{AC})$	Minimum Input Swing <sup>8</sup>		250			250			250			250		mV	
$V_{CMR}$	Common Mode Range <sup>9</sup>	$V_{EE} + 1.8$		$V_{CC} - 0.4$	$V_{EE} + 1.8$		$V_{CC} - 0.4$	$V_{EE} + 1.8$		$V_{CC} - 0.4$	$V_{EE} + 1.8$		$V_{CC} - 0.4$	V	
$t_r / t_f$	Rise/Fall Time		250		650		275		600		275		600	ps	

- The differential propagation delay is defined as the delay from the crossing point of the differential input signals to the crossing point of the differential output signals.
- The single-ended propagation delay is defined as the delay from the 50% point of the input signal to the 50% point of the output signal.
- Enable is defined as the propagation delay from the 50% point of a negative transition on EN to the 50% point of a positive transition on Q (or a negative transition on  $\bar{Q}$ ). Disable is defined as the propagation delay from the 50% point of a positive transition on EN to the 50% point of a negative transition on Q (or a positive transition on  $\bar{Q}$ ).
- The within-device skew is defined as the worst-case difference between any two similar delay paths within a single device.
- The setup time is the minimum time that EN must be asserted prior to the next transition of IN/ $\bar{IN}$  to prevent an output response greater than  $\pm 75\text{mV}$  to that IN/ $\bar{IN}$  transition (see Figure 1).
- The hold time is the minimum time that EN must remain asserted after a negative going IN or a positive going  $\bar{IN}$  to prevent an output response greater than  $\pm 75\text{mV}$  to that IN/ $\bar{IN}$  transition (see Figure 2).
- The release time is the minimum time that EN must be de-asserted prior to the next IN/ $\bar{IN}$  transition to ensure an output response that meets the specified IN to Q propagation delay and output transition times (see Figure 3).
- $V_{PP}$  is defined as the minimum peak-to-peak differential input swing for which AC parameters are guaranteed. The  $V_{PP}(\text{min})$  is AC limited for the LVE111E, because differential input as low as 50 mV will still produce full ECL levels at the output.
- $V_{CMR}$  is defined as the range within which the  $V_{IH}$  level may vary, with the device still meeting the propagation delay specification. The  $V_{IL}$  level must be such that the peak-to-peak voltage is less than 1.0 V and greater than or equal to  $V_{PP}(\text{min})$ .

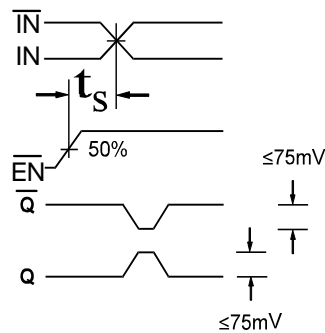

Figure 1. Setup Time

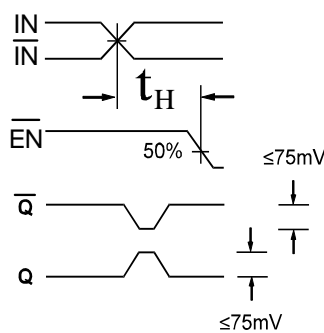

Figure 2. Hold Time

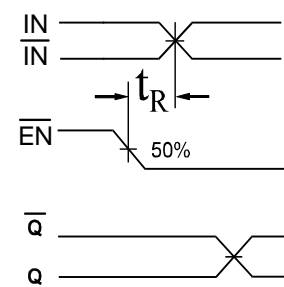
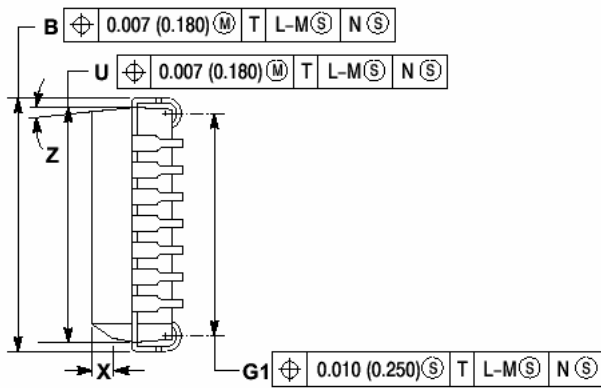
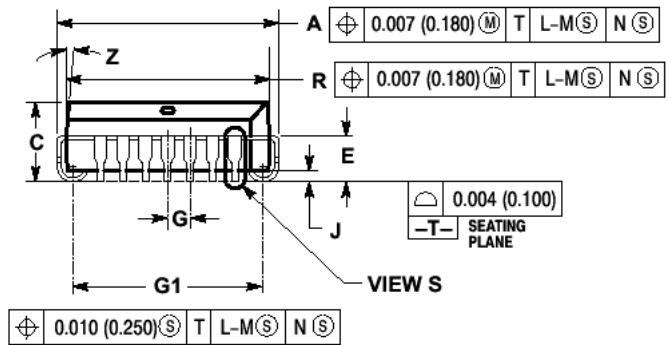
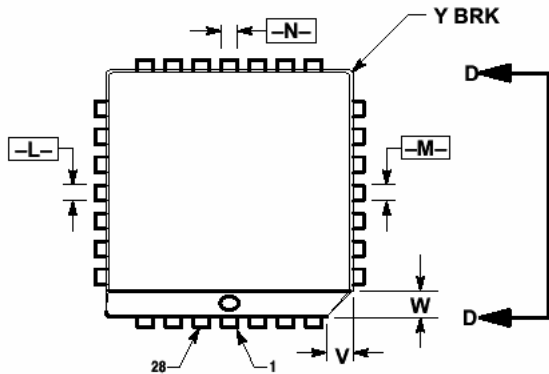

Figure 3. Release Time

AZ10LVE111E  
AZ100LVE111E

**PACKAGE DIAGRAM  
PLCC 28**



VIEW D-D

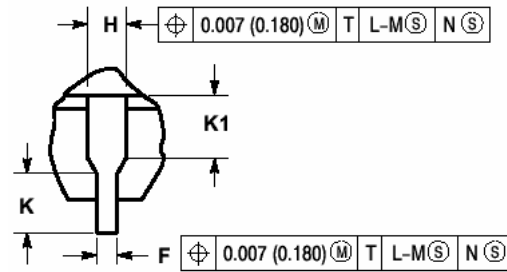

VIEW S

DIM	MILLIMETERS		INCHES	
	MIN	MAX	MIN	MAX
A	12.32	12.57	0.485	0.495
B	12.32	12.57	0.485	0.495
C	4.20	4.57	0.165	0.180
E	2.29	2.79	0.090	0.110
F	0.33	0.48	0.013	0.019
G	1.27 BSC		0.050 BSC	
H	0.66	0.81	0.026	0.032
J	0.51		0.020	
K	0.64		0.025	
R	11.43	11.58	0.450	0.456
U	11.43	11.58	0.450	0.456
V	1.07	1.21	0.042	0.048
W	1.07	1.21	0.042	0.048
X	1.07	1.42	0.042	0.056
T		0.50		0.020
Z	2°	10°	2°	10°
G1	10.42	10.92	0.410	0.430
K1	1.02		0.040	

NOTES:

- DATUMS -L-, -M-, AND -N- DETERMINED WHERE TOP OF LEAD SHOULDER EXITS PLASTIC BODY AT MOLD PARTING LINE.
- DIMENSION G1, TRUE POSITION TO BE MEASURED AT DATUM -T-, SEATING PLANE.
- DIMENSIONS R AND U DO NOT INCLUDE MOLD FLASH. ALLOWABLE MOLD FLASH IS 0.010mm (0.250in.) PER SIDE.
- DIMENSIONING AND TOLERANCING PER ANSI Y14.5M, 1982.
- CONTROLLING DIMENSION: INCH.
- THE PACKAGE TOP MAY BE SMALLER THAN THE PACKAGE BOTTOM BY UP TO 0.012mm (0.300in.). DIMENSIONS R AND U ARE DETERMINED AT THE OUTERMOST EXTREMES OF THE PLASTIC BODY EXCLUSIVE OF MOLD FLASH, THE BAR BURRS, GATE BURRS AND INTERLEAD FLASH, BUT INCLUDING ANY MISMATCH BETWEEN THE TOP AND BOTTOM OF THE PLASTIC BODY.
- DIMENSION H DOES NOT INCLUDE DAMBAR PROTRUSION OR INTRUSION. THE DAMBAR PROTRUSION(S) SHALL NOT CAUSE THE H DIMENSION TO BE SMALLER THAN 0.025mm (0.635in.).

**AZ10LVE111E**  
**AZ100LVE111E**

Arizona Microtek, Inc. reserves the right to change circuitry and specifications at any time without prior notice. Arizona Microtek, Inc. makes no warranty, representation or guarantee regarding the suitability of its products for any particular purpose, nor does Arizona Microtek, Inc. assume any liability arising out of the application or use of any product or circuit and specifically disclaims any and all liability, including without limitation special, consequential or incidental damages. Arizona Microtek, Inc. does not convey any license rights nor the rights of others. Arizona Microtek, Inc. products are not designed, intended or authorized for use as components in systems intended to support or sustain life, or for any other application in which the failure of the Arizona Microtek, Inc. product could create a situation where personal injury or death may occur. Should Buyer purchase or use Arizona Microtek, Inc. products for any such unintended or unauthorized application, Buyer shall indemnify and hold Arizona Microtek, Inc. and its officers, employees, subsidiaries, affiliates, and distributors harmless against all claims, costs, damages, and expenses, and reasonable attorney fees arising out of, directly or indirectly, any claim of personal injury or death associated with such unintended or unauthorized use, even if such claim alleges that Arizona Microtek, Inc. was negligent regarding the design or manufacture of the part.