

SPECIFICATION FOR APPROVAL

REF :

PAGE: 1

PROD. NAME	MULTILAYER CHIP INDUCTOR	ABC'S DWG NO.	MH2012□□□□L□-□□□
		ABC'S ITEM NO.	

I . CONFIGURATION & DIMENSIONS :

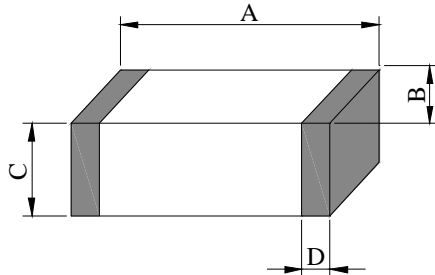

- A : 2.00±0.20 m/m
- B : 1.20±0.20 m/m
- C : 0.85±0.20 m/m
- D : 0.50±0.30 m/m

II . SCHEMATIC DIAGRAM :



III . FEATURES :

- a . Monolithic structure ensuring high performance and reliability.
- b . High frequency applications up to 6GHz.
- c . Terminal : Ag/Cu/Ni/Sn
- d . Remark : Products comply with RoHS' requirements

IV . APPLICATIONS :

- a . RF modules for telecommunication systems including GSM, PCS, DECT, WLAN, Bluetooth, etc.

Peak Temp : 260°C max.
 Max time above 230°C : 50sec max.
 Max time above 200°C : 70sec max.

V . GENERAL SPECIFICATION :

- a . Storage temp. : -55°C --- +125°C
- b . Operating temp. : -55°C --- +125°C
- c . Solderability : Preheat 150°C . 60 sec
 Solder : H63A
 Solder temp. : 230±5°C
 Flux : Rosin
 Dip time : 4±1 sec

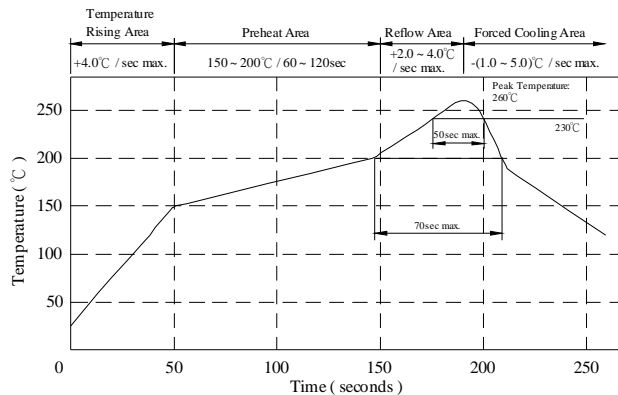

AR-001A

SPECIFICATION FOR APPROVAL

REF :

PAGE: 2

PROD. NAME	MULTILAYER CHIP INDUCTOR	ABC'S DWG NO.	MH2012□□□□L□-□□□
		ABC'S ITEM NO.	

VI . ELECTRICAL CHARACTERISTICS :

DWG No.	Inductance (nH)	Q _{min}	L/Q Test Freq. (MHz)	SRF (MHz) nom	RDC (Ω) max	IDC (mA) max
MH20121N2DL□-□□□	1.2 ± 0.3	10	100	>6000	0.10	300
MH20121N5DL□-□□□	1.5 ± 0.3	10	100	>6000	0.10	300
MH20121N8DL□-□□□	1.8 ± 0.3	10	100	>6000	0.10	300
MH20122N2DL□-□□□	2.2 ± 0.3	10	100	>6000	0.10	300
MH20122N7DL□-□□□	2.7 ± 0.3	12	100	>6000	0.12	300
MH20123N3DL□-□□□	3.3 ± 0.3	12	100	>6000	0.13	300
MH20123N9DL□-□□□	3.9 ± 0.3	12	100	5600	0.15	300
MH20124N7DL□-□□□	4.7 ± 0.3	12	100	5500	0.20	300
MH20125N6DL□-□□□	5.6 ± 0.3	12	100	4700	0.23	300
MH20126N8JL□-□□□	6.8 ± 5%	15	100	3900	0.25	300
MH20128N2JL□-□□□	8.2 ± 5%	15	100	3200	0.28	300
MH201210NJL□-□□□	10.0 ± 5%	15	100	3100	0.30	300
MH201212NJL□-□□□	12.0 ± 5%	15	100	2800	0.35	300
MH201215NJL□-□□□	15.0 ± 5%	15	100	2400	0.40	300
MH201218NJL□-□□□	18.0 ± 5%	15	100	2100	0.45	300
MH201222NJL□-□□□	22.0 ± 5%	15	100	2000	0.50	300
MH201227NJL□-□□□	27.0 ± 5%	15	100	1800	0.55	300
MH201233NJL□-□□□	33.0 ± 5%	15	100	1700	0.60	300
MH201239NJL□-□□□	39.0 ± 5%	18	100	1400	0.65	300
MH201247NJL□-□□□	47.0 ± 5%	18	100	1200	0.70	300
MH201256NJL□-□□□	56.0 ± 5%	18	100	1000	0.75	300
MH201268NJL□-□□□	68.0 ± 5%	18	100	900	0.80	300
MH201282NJL□-□□□	82.0 ± 5%	18	100	900	0.85	300
MH2012R10JL□-□□□	100.0 ± 5%	18	100	700	0.90	300
MH2012R12JL□-□□□	120.0 ± 5%	13	50	600	0.95	300
MH2012R15JL□-□□□	150.0 ± 5%	13	50	500	1.00	300
MH2012R18JL□-□□□	180.0 ± 5%	13	50	430	1.10	300
MH2012R22JL□-□□□	220.0 ± 5%	12	50	400	1.20	300
MH2012R27JL□-□□□	270.0 ± 5%	12	50	340	1.30	300
MH2012R33JL□-□□□	330.0 ± 5%	12	50	320	1.50	300

1). □ : Packaging Information... [A]: Bulk [B]: Taping Reel

2). "-□□□": Reference code

SPECIFICATION FOR APPROVAL

REF :

PAGE: 3

PROD. NAME	MULTILAYER CHIP INDUCTOR	ABC'S DWG NO.	MH2012□□□□L□-□□□
		ABC'S ITEM NO.	

VII . L / Q VS. FREQ. CURVE :

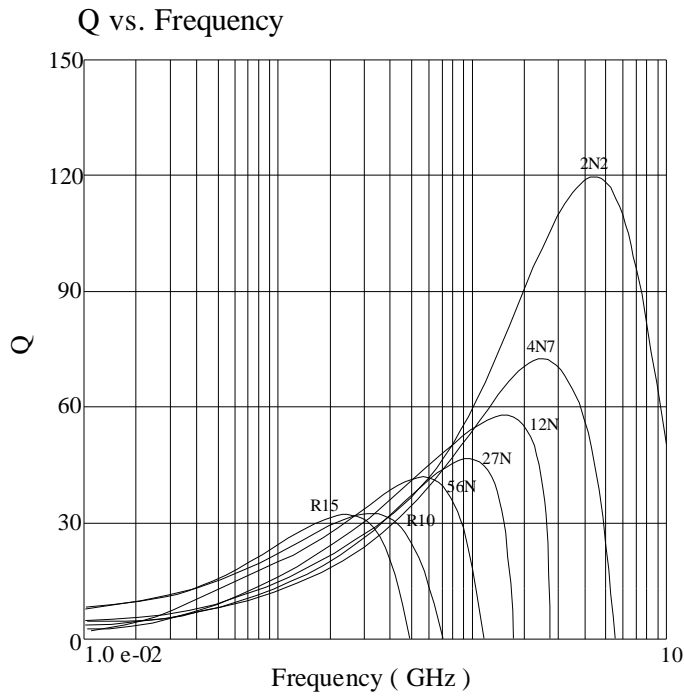
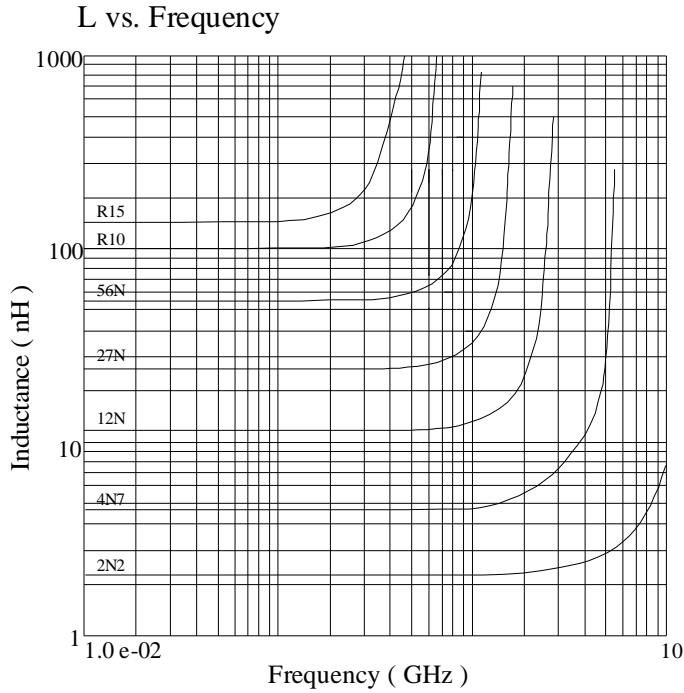

AR-001A

SPECIFICATION FOR APPROVAL

REF :

PAGE: 4

PROD. NAME MULTILAYER CHIP INDUCTOR	ABC'S DWG NO.	MH2012□□□□Lo-□□□
	ABC'S ITEM NO.	

VIII . PACKAGING INFORMATION :

(1) Configuration

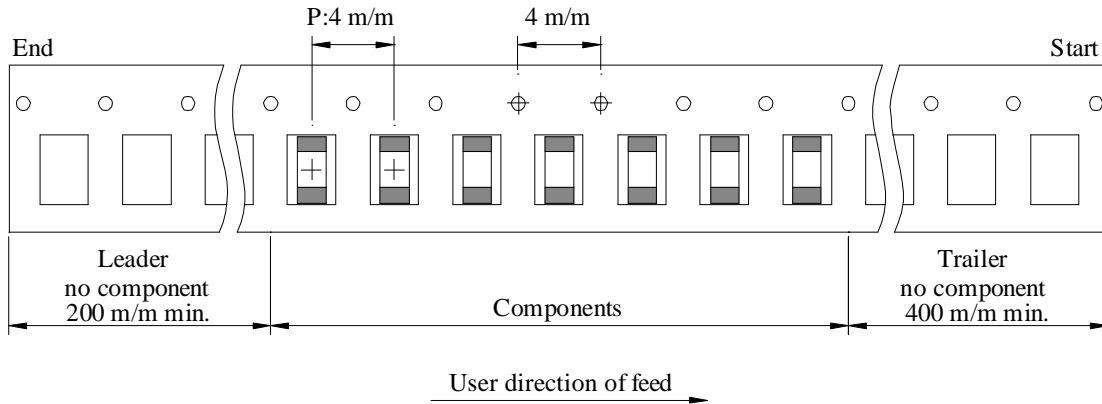
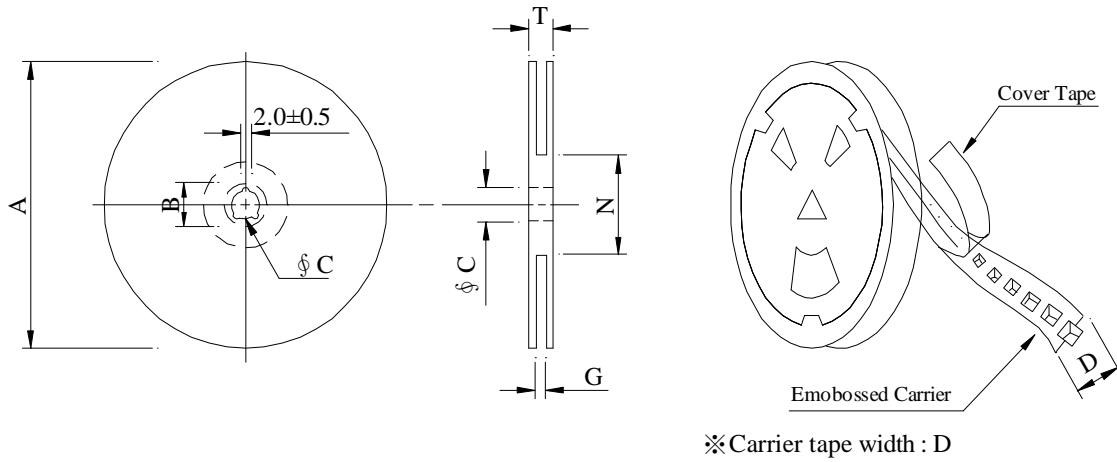

(2) Dimensions

Unit:m/m

Style	A	B	C	D	G	N	T
07 - 08	178	21±0.8	13	8	10 ⁺⁰	50 ⁻⁰	12.5

(3) Q'TY & G.W. Per package

Series	Inner : Reel			Outer : Carton		
	Q'TY (pcs)	G.W. (gw)	Style	Q'TY (pcs)	G.W. (Kg)	Size (cm)
MH2012	4,000	120	07 - 08	200,000	8.5	41 x 39 x 22

AR-001A

SPECIFICATION FOR APPROVAL

REF :

PAGE: 5

PROD. NAME	MULTILAYER CHIP INDUCTOR	ABC'S DWG NO.	MH2012□□□□L□-□□□
		ABC'S ITEM NO.	

(4) TYPE DIMENSIONS

Fig 1.

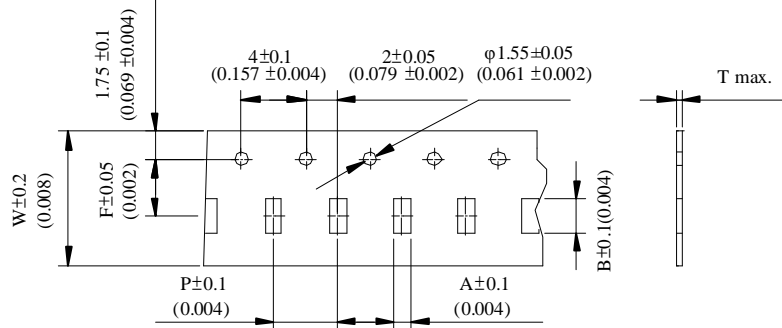

Unit:m/m

Type	A	B	F	P	T	W	Fig
MH2012	1.50	2.30	3.50	4.0	1.10	8.0	1

SPECIFICATION FOR APPROVAL

REF :

PAGE: 6

PROD. NAME	MULTILAYER CHIP INDUCTOR	ABC'S DWG NO.	MH2012□□□□L□-□□□
		ABC'S ITEM NO.	

IX . DWGING NUMBER EXPRESSION :

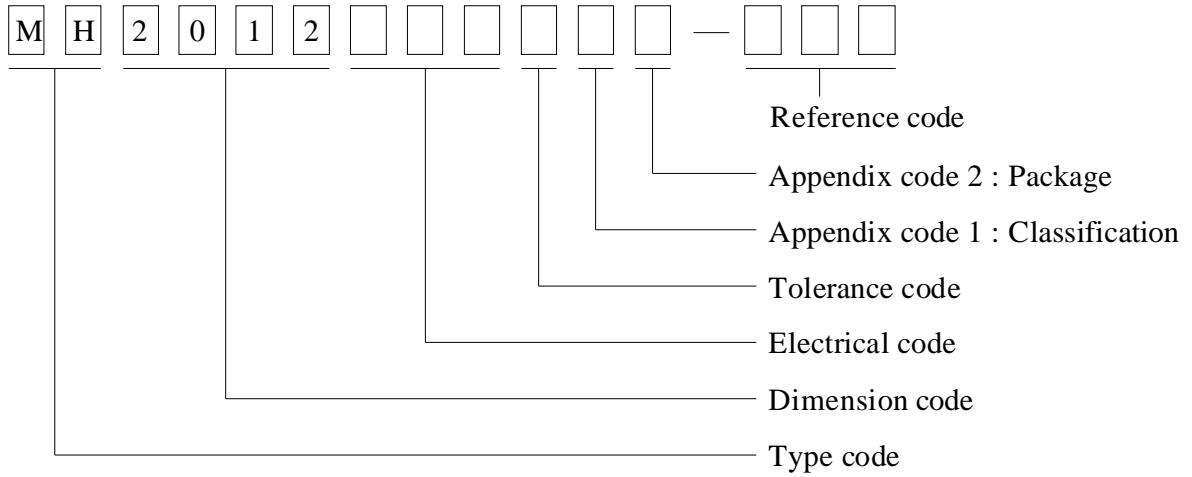

Appendix code 1 : Product Classification

L : Lead Free Standard products comply with RoHS' requirements

1 ~ 9 : Lead Free Special products comply with RoHS' requirements

Appendix code 2 : Package Information

Code	Inner package	Inner package Q'TY	Remark
A	T.B.D.	T.B.D.	
B	T / R (Reel package)	4000 pcs	