

- TTL/CMOS Compatible
- Tri-State Feature for Auto Test Systems
- Fast Rise and Fall Times
- 70 to 120 MHz Frequency Range
- Tight Symmetry (45/55%) Available
- ± 100 ppm Stability Standard
- ± 50 ppm Stability Available - K1350

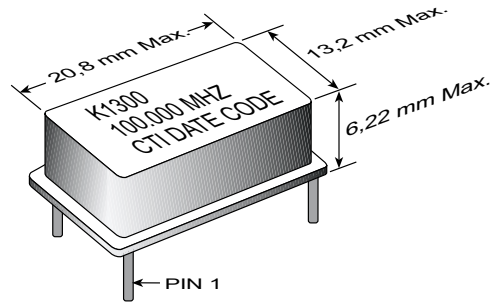

ELECTRICAL SPECIFICATIONS

MODEL	K1300	K1350
Frequency Range (MHz)	70 to 120	
Frequency Stability (ppm)	Inclusive of calibration, temperature, voltage, load, shock, vibration, aging	
Overall (Typical)	± 100	± 50
0°C to 70°C		
Temperature Range (°C)	Operating: 0°C to +70°C	
Operating	Storage: -55°C to +125°C	
Storage	Supply Voltage (V) : +5.0 $\pm 5\%$	
Supply Voltage (V)	Output TTL	
Output TTL	Input Current (mA): 50 - 80 max	
Input Current (mA)	Symmetry (%): 40/60 @ 1.4V	
Symmetry (%)	T_R and T_F (ns): 5 (0.5V to 2.5V)	
T_R and T_F (ns)	Fanout: 10	
Fanout	Output CMOS	
Output CMOS	Input Current (mA): 100 max	
Input Current (mA)	Symmetry (%): 40/60 @ 0.5V _{CC}	
Symmetry (%)	T_R and T_F (ns): 5 (20% - 80% V _{CC})	
T_R and T_F (ns)	Start up Time (ms)	
Start up Time (ms)	TTL: <10	
TTL	CMOS: <45	
CMOS		

PART NUMBERING GUIDE

K13XXXX - Specify Frequency

“Blank” = TTL Output

“C” = CMOS Output

“Blank” = 40/60% Symmetry

“S” = 45/55% Symmetry (Available to 100MHz.)

“00” = ± 100 ppm Stability

“50” = ± 50 ppm

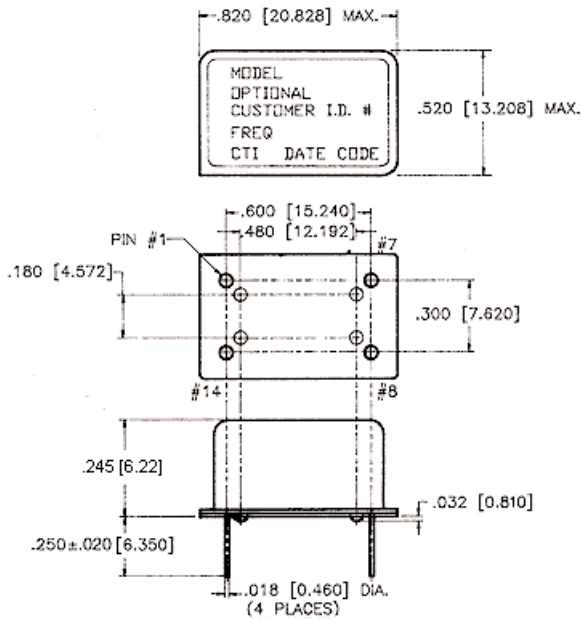

PIN	FUNCTION
1	Tri-State*
2	Ground
3	Output
4	+V _{CC}

* Input tied internally to +5V. External input if any, should not be less than +3V and not greater than +3.8V for TTL version. For CMOS models, enable with either an open circuit or +5V.

SHIPPING TUBE CROSS SECTION

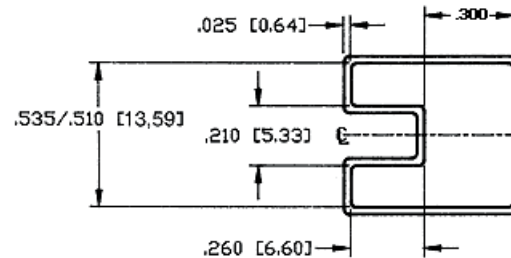

ALL DIMENSIONS ARE INSIDE

OUTPUT WAVEFORM

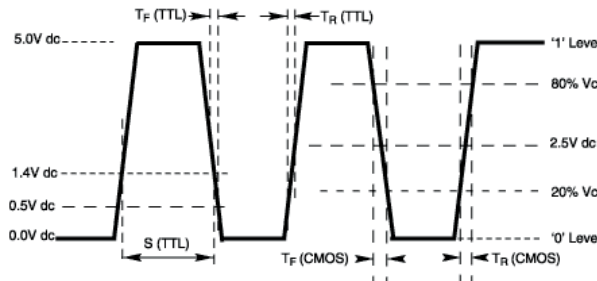

TEST CIRCUIT DIAGRAM

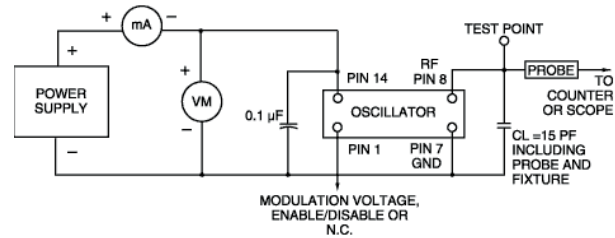

MECHANICAL AND ENVIRONMENTAL SPECIFICATIONS

TEST METHODS	REFERENCE PROCEDURES	DESCRIPTION
Temperature Cycle	MIL-STD-833, Mtd 1010, Cond. B	-55°C to +125°C; Air-to-Air; 100 cycles; 10 min. dwell
Mechanical Shock	MIL-STD-883, Mtd 2002, Cond. B	1500 g's
Vibration	MIL-STD 883, Mtd 2007, Cond. B	20-2000 Hz; 0.06 inch; 15g's; 3 planes
Humidity Steady State	MIL-STD-202, Mtd 103	40°C; 90%-95% R.H.; 56 days
Thermal Shock	MIL-STD-883, Mtd 1011.7 Cond. B	100°C to 0°C; Water-to-Water; 15 cycles
Electrostatic Discharge	MIL-STD-883, Mtd 3015 Class II	2 KV to 4 KV Threshold
Solderability	MIL-STD-883, Mtd 2022.2	Solder dip; Meniscograph Criteria
Hermeticity	MIL-STD-883, Mtd 1014.8, Cond. A1	Mass spectro. 2 x 10 ⁻⁸ atmos. CC/sec He
Resistance to Soldering	MIL-STD-202, Mtd 210D, Cond. J	235°C; 30 seconds
Lead Integrity	MIL-STD-883, Mtd 2004.5, Cond. A, B1	Lead tension & bend stress
Marking Permanence	MIL-STD-883, Mtd 2015.8	Resistance to solvents
Life Test	MIL-STD-883, Mtd 1005.6	125°C, powered, 1000 hours minimum