



Smart Technology. Delivered.

AA-250-XX

OUTDOOR THERMOELECTRIC
COOLER ASSEMBLY
USER MANUAL



Contents

Introduction	3
Incoming Inspection	3
General Safety and Warnings.....	3
Technical Specifications	4
Installation and Operation Instructions	6
Serviceability	8
Warranty	8
Return Procedure.....	8

Revision History

Revision	Description
1	Initial Version
2	Over-Temp Thermostat Clarification

Americas: +1 888.246.9050
Europe: +46 31 420530
Asia: +86 755 2714.1166

THR-UM-AA-250-XX 090414

Any information furnished by Laird and its agents is believed to be accurate and reliable. All specifications are subject to change without notice. Responsibility for the use and application of Laird materials rests with the end user, since Laird and its agents cannot be aware of all potential uses. Laird makes no warranties as to the fitness, merchantability or suitability of any Laird materials or products for any specific or general uses. Laird, Laird Technologies, Inc or any of its affiliates or agents shall not be liable for incidental or consequential damages of any kind. All Laird products are sold pursuant to the Laird Technologies' Terms and Conditions of sale in effect from time to time, a copy of which will be furnished upon request. © Copyright 2014 Laird Technologies, Inc. All Rights Reserved. Laird, Laird Technologies, the Laird Logo, and other marks are trademarks or registered trademarks of Laird Technologies, Inc. or an affiliate company thereof. Other product or service names may be the property of third parties. Nothing herein provides a license under any Laird or any third party intellectual property rights.

Introduction

Laird Technologies' Outdoor Cooler Series is an Air to Air thermoelectric assembly that uses impingement flow to transfer heat. It offers dependable compact performance by cooling objects via convection and is designed to provide cooling for a wide range of outdoor environments in the telecom, industrial and kiosk markets. They are intended to work in an open loop system or if purchased with a bi-polar controller in a closed loop system with feedback control.

Heat is absorbed and dissipated thru high density heat exchangers equipped with air ducted shrouds and brand name fans. The heat pumping action occurs from custom designed thermoelectric modules that achieve a high coefficient of performance (COP) to minimize power consumption.

This product series has been designed to pass rigorous Telcordia test requirements, such as earthquake resistance, salt fog, wind-driven rain, high temperature exposure and dust contaminants. This is due to the selection of world class components such as brand fans with the highest degree of environmental protection, waterproof connectors, heavy duty anodization on the heat exchangers, overheat protection, and double environmental seals for the thermoelectric modules.

This manual provides the necessary general information for proper installation and operation that has been developed to achieve the best results when using a Laird Technologies Outdoor Cooler Series product.

Incoming Inspection

Laird Technologies' Outdoor Coolers are designed, built, and packaged to withstand the shock and vibration associated with normal transit means by common carriers. Occasionally, improper handling during shipment may cause damage to the product. Therefore, packages should be opened promptly and inspected for damage. Any packaging tears, dents, scratches, or loose objects should be noted on the Freight Bill. If damage is found, an immediate claim must be filed with the freight carrier. Retain all packing materials. Laird Technologies cannot be responsible for Consignee's failure to file a freight claim in a timely manner.

General Safety Warning

WARNING **Electrical Shock Hazard**

INSTALL UNIT TO CABINET WALL FIXTURE PRIOR TO POWERING DEVICE. OPERATIONAL VOLTAGE SHOULD COMPLY TO NOMINAL RATING ON LABEL. ENSURE THAT THERE IS AN EXTERNAL FUSE IN LINE WITH OUTDOOR COOLER TO PROTECT INPUT POWER LINES TO UNIT.

Technical Specifications

Part Number Nomenclature

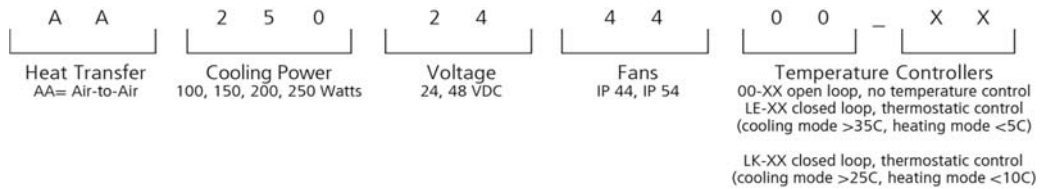

Consult with Laird Technologies for custom designed bi-polar controller features or alarms.

Specifications

TECHNICAL	
Technology	Thermoelectric modules, forced air, closed loop (not mixing with outside air), filter-less, non-refrigerant
Cooling at $\Delta T = 0^{\circ}\text{C}$, and nominal / float voltage ¹	244/262W (832/894 Btu/hr)
Heating ²	250W (853 Btu/hr)
Voltage (nominal / maximum)	24/28 VDC 48/56 VDC
Current draw, $\pm 10\%$ (nominal)	12.1 Amps 6.1 Amps
Grounding (all voltages)	Positive or negative
Weight	6.3 kg (16.9 lbs)
Panel mounting	Through mount
Fan life (L^{10} at $+40^{\circ}\text{C}$)	$\geq 70,000$ hours
Connector type	Terminal block with cage clamp (12-28 AWG)
Hi-pot testing	707 VDC
ENVIRONMENTAL	
Temperature range ³ (external ambient)	-40°C to $+55^{\circ}\text{C}$ (-40°F to $+131^{\circ}\text{F}$)
Temperature range (internal enclosure)	-20°C to $+55^{\circ}\text{C}$ (-4°F to $+131^{\circ}\text{F}$)
Degree of protection, enclosure ⁴	NEMA 4 (IP55)
Degree of protection, unit ⁵	IP54
Sound level (1m distance)	63 dB(A)
Over-Temp Thermostat (internal/external heat sink)	$75^{\circ}\text{C} \pm 5^{\circ}\text{C}$ (optional)

1) Cooling capacities at nominal / float voltage are rated at external temperatures of 35°C and 50°C respectively. Float voltage is defined at 28 VDC for 24 volt version or 54 VDC for 48 volt version.

2) Heating capacity is rated at external temperature of -40°C , nominal voltage, and $\Delta T = 45^{\circ}\text{C}$.

3) Controller function should not operate the external fan during heating mode. This will pull heat out of the cabinet.

4) The highest environmental protection level requires an external shroud and is defined as the protection level for the enclosure.

5) Rating for unit without protective shroud.

Note: The specified performance of any Laird Technologies cooling unit is dependent on how it is handled and incorporated into the final product. This includes elements such as the system design, insulation design, and assembly method. While Laird Technologies is able to provide general guidelines based upon our experience, it is ultimately the responsibility of the OEM to validate each product and its performance for its intended use.

Performance Curve

The cooling capacity was conducted at an ambient temperature of 35°C. Performance will deviate based on ambient temperature condition.

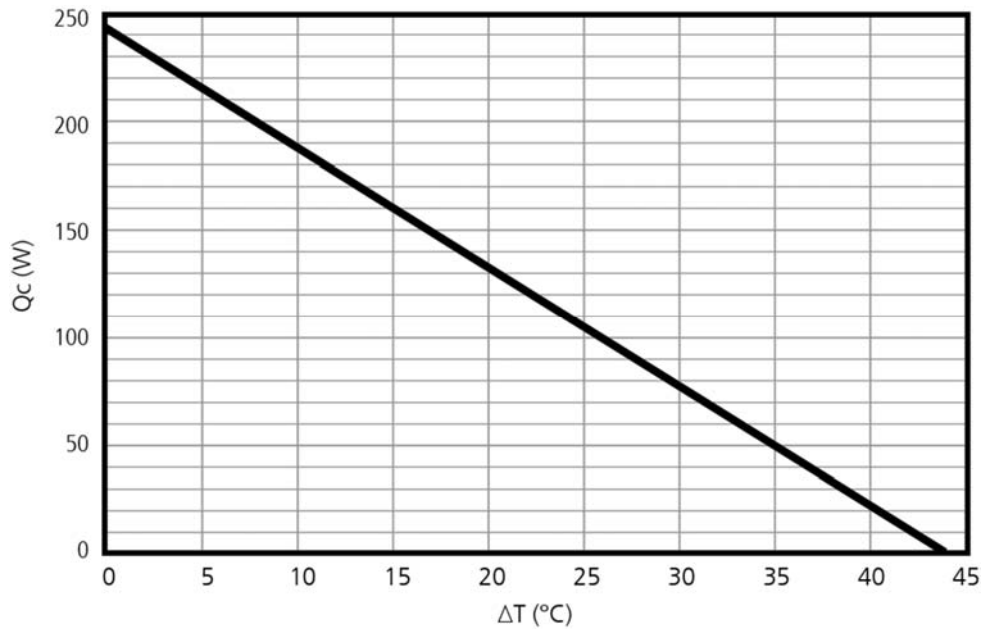

Isometric Drawing

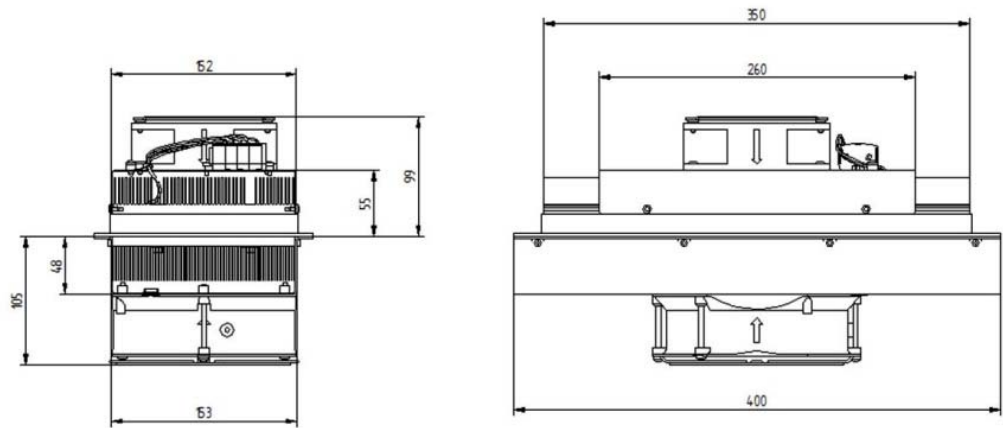

Installation and Operation Instructions

Reducing the passive heat load is critical to yield the highest efficiency out of an Outdoor Cooler and maximize service life. It is important to insulate the walls of an enclosure with as much insulation material as permissible without interfering with nearby electronics or system level obstructions. Proper insulation of the enclosure can result in sizing a lower capacity Outdoor Cooler unit and power supply, which can reduce total system costs.

The Outdoor Cooler is mounted onto a cabinet wall with the “Hot Side” mounted external to the cabinet. This is required to dissipate heat out of the cabinet. It is also important to have good ventilation on the hot side to transport heat exhaust away from the cabinet. A minimum of one fan thickness is required from the wall surface to the exterior face of the fan to allow air to enter into the fan and transport the exhaust through the ducted shroud.

Outdoor Coolers cool below ambient, so it is important to run them in a cabinet that is sealed from the outside environment. If the dew point is reached, then moisture in the air will condense onto the cold side heat exchanger. Access to outside air exchange can accelerate the moisture condensation rate and cause large amounts of moisture to accumulate on the cold surfaces of the Outdoor Cooler, which could degrade operation life over time if the system is not designed to drain condensation. It is recommended to mount the Outdoor Cooler in a vertical orientation, so condensation runs off the cold side heat exchanger. If the enclosure cannot accommodate this, then the Outdoor Cooler should be installed at a minimum of a 15 degree angle in horizontal orientation to allow for condensation to run off the cold side heat exchanger.

The Outdoor Cooler must be protected from vandalism or external forces that may bump up against unit and cause damage.

Mounting and Hardware

The enclosure should be sealed from the outside environment by maintaining good compression between the Outdoor Cooler and cabinet wall. The Outdoor Coolers are designed to be through mount, so a cut out on the enclosure wall will be required to accommodate the cold side heat exchanger. Reference the below diagram for mounting hole locations and cold side heat exchanger dimensions. The cut out should be 2.5 mm’s larger than the cold side heat exchanger. Six mounting holes are available to fasten the Outdoor Cooler unit to cabinet wall. The mounting holes are designed to accommodate M6 machine hardware as shown in diagram. External tooth lock washers are recommended to prevent the Outdoor Cooler from loosening over time.

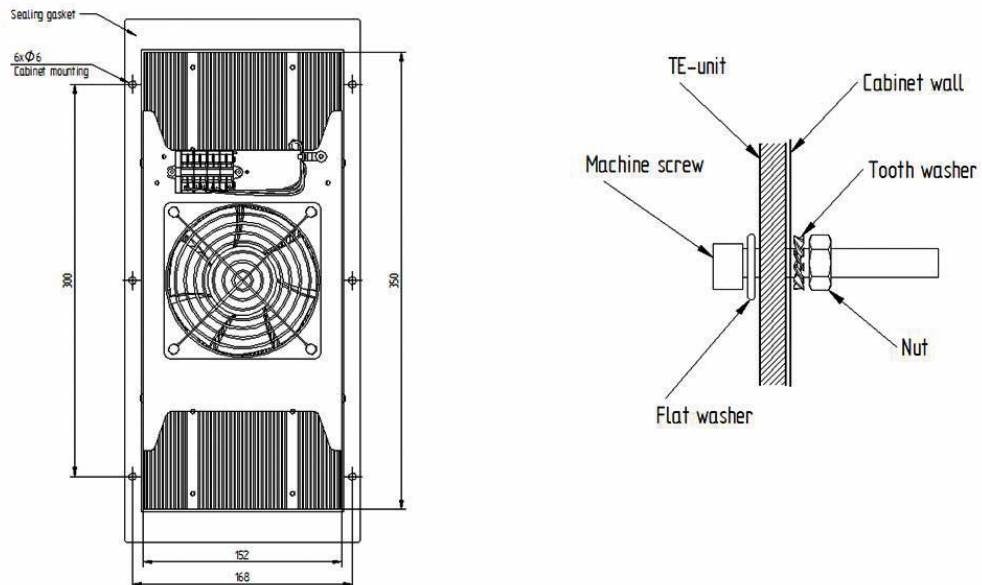

Schematic

Outdoor Coolers come with a durable simple to use cage clamp. Wires should be stripped back 6 mm's in length and inserted into connector. The connector can accommodate wire sizes of 12 to 28 AWG. For input power to TEM 16 AWG stranded copper wire is recommended. For input power to fans 18 AWG stranded copper wire is recommended.

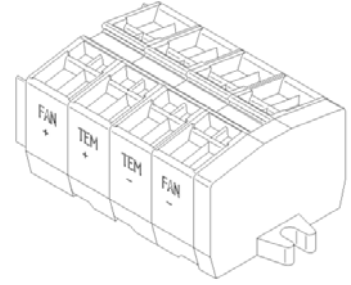

Internal schematic of Outdoor Cooler Unit.

(24 Volt schematic shown)

1. Connect external fuse in line with input power connector to protect input power lines from shorting.
2. Input voltage must not exceed rating on label of unit. Maximum ripple current should not exceed three percent of nominal value.

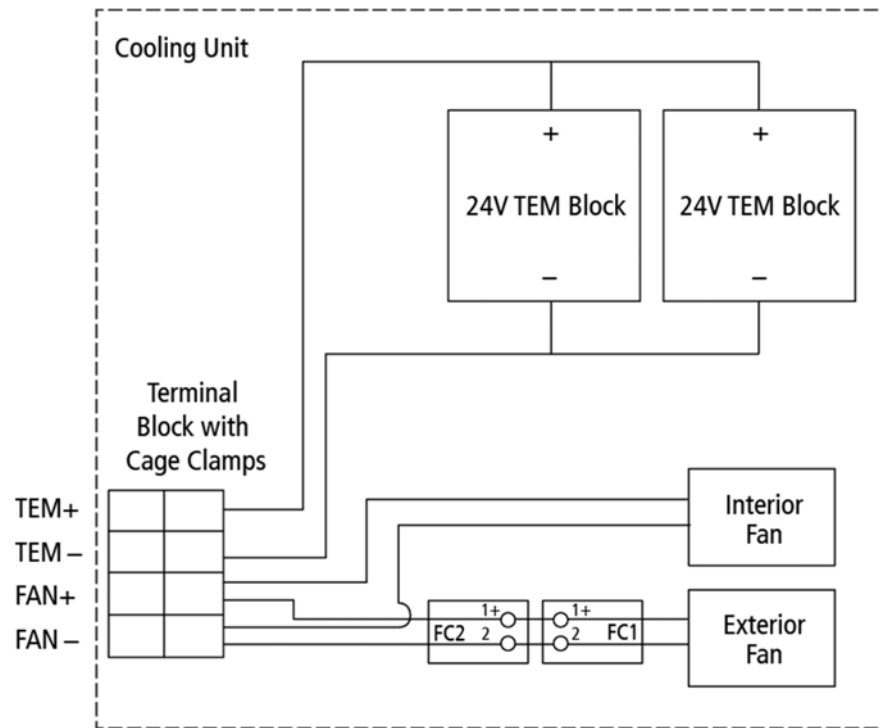

Serviceability

No special maintenance is required when using Laird Technologies Outdoor Coolers. For continued optimal performance and extended life of the unit, it is recommended to clean the (internal/external) heat sinks and fans periodically as they will accumulate dust from outside contaminants over time. If a unit is not performing properly consult with Laird Technologies.

Warranty

Laird Technologies Outdoor Coolers are manufactured in an ISO 9001:2008 facility. Units adhere to the highest quality standards and are free from defects in material, components, and workmanship. This warranty covers repair or replacement of product, to be done at a Laird Technologies facility, for a period of two (2) years from date of shipment. Customer is responsible for shipping product to Laird Technologies freight prepaid. Laird Technologies in turn will return the warranted product to customer freight prepaid, if within the time period specified above. Warranty coverage is in effect when the following operating conditions are continuously satisfied:

- Ambient Temperature Range within -40°C to 55°C.
- Line Voltage variation within plus or minus 12.5% of nameplate rating.

In addition, the following criteria must be met:

- Electrical installation and grounding must comply with local electrical and safety codes.
- Outdoor Cooler must be used in the environment for which it is designed.
- Customer cannot abuse or mishandle the product in any way. Any modifications to the original unit will also void warranty.
- Compliance to User's Manual or any other instructional guide provided by Laird Technologies for the product.

This warranty does not cover the following:

- Applications where product is being misapplied. This includes inappropriate selection of Outdoor Cooler for the environment and conditions in which it is to be used.
- Damages caused by shipping carrier or any other accident after product has left Laird Technologies. Shipping claims are the responsibility of the customer and are to be completed in a timely manner.
- Reimbursement of labor for installation or removal of warranted product, or for parts and labor resulting from repairs performed by any other source besides Laird Technologies.

This is the complete warranty and is in lieu of any other warranty expressed or implied, including but not limited to any implied warranty of merchantability or fitness for a particular purpose. Laird Technologies will in no way be liable for incidental or consequential damage whatsoever or for any other claims by the customer for damages in connection with Laird Technologies products, even if advised in advance of the possibility of such damage.

Return Procedure

All returns must be assigned a Non-Conformance Material Return Authorization number (NCMR#) in advance. Returns received without NCMR# may be refused. In the event that a return is required, the Customer should call Laird Technologies' Customer Service Department at USA: +1 888.246.9050, Europe: +44.1342.315044; Asia: +886.3.312.9292 or send an email to clv.customerpos@lairdtech.com. The Customer will be asked to fill out an NCMR form so that NCMR number can be issued. All returns must be securely packaged to prevent shipping damage and must be clearly marked with the NCMR number on the box. Consignor shall pay freight charges on all returns.