

Reflective Object Sensor

OPB708, OPB709

OPB740 Series, OPB740WZ Series



Features:

- Focused for maximum sensitivity
- Phototransistor or photodarlington output
- Crosstalk does not exceed specified ICEO
- 24" (610 mm) wire length
- 26 AWG wire size

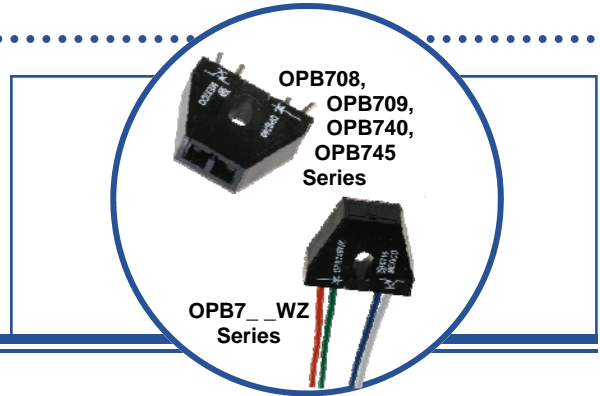

Description:

Each reflective object sensor in the **OPB708, OPB709, OPB740** through **OPB746** and **OPB740WZ** through **OPB746WZ** series consists of an infrared emitting diode and a NPN silicon phototransistor or a photodarlington. The **OPB747WZ** and **OPB748WZ** consist of a Red visible LED and a low light level rejection (R_{BE}) NPN silicon phototransistor. The Red LED allows better contrast ratio when detecting Black marks on a White surface. All these devices are mounted side-by-side on converging optical axes in a black plastic housing focusing on a small area and depth of field.

OPB7 __ WZ series are wired (UL approved wire) devices that offer various lens options, including no windows, blue polysulfone windows for dust protection or opaque aperture windows with offset openings for improved target resolution.

On each sensor included in this data sheet, the photosensor responds to radiation only when a reflective object passes within its field of view.

Custom IC(ON) current binning, special wire lengths and connectorization is available through your OPTEK rep.

Applications:

- Non-contact reflective object sensor
- Assembly line automation
- Machine automation
- Machine safety
- End of travel sensor
- Door sensor
- Thermal Paper Mark

Part Number	LED Peak Wavelength	Sensor	Reflection Distance Inch (mm)	Lead Length/Wire Type
OPB708	935 nm	Transistor	Min=0.08" [2.04mm] Typ=0.15" [3.81mm] Max=0.30" [7.62mm]	0.150" Minimum
OPB709		Darlington		
OPB740	890 nm	Transistor		
OPB741				
OPB742				
OPB743				
OPB744				
OPB745				
OPB740WZ				Darlington
OPB741WZ	Transistor	24" / 26 AWG Wire		
OPB742WZ				
OPB743WZ				
OPB744WZ				
OPB745WZ				Darlington
OPB746WZ	935 nm		R_{BE} Transistor	
OPB747WZ	645nm			
OPB748WZ			Transistor	

CONTAINS POLYSULFONE
To avoid stress cracking, we suggest using ND Industries' **Vibra-Tite** for thread-locking. **Vibra-Tite** evaporates fast without causing structural failure in OPTEK's molded plastics. Applies to: **OPB460, OPB470, OPB480, OPB490.**



RoHS

OPTEK reserves the right to make changes at any time in order to improve design and to supply the best product possible.

Reflective Object Sensor
OPB708, OPB709
OPB740 Series, OPB740WZ Series



OPB708, OPB709, OPB740, OPB741,
OPB742, OPB743, OPB744, OPB745

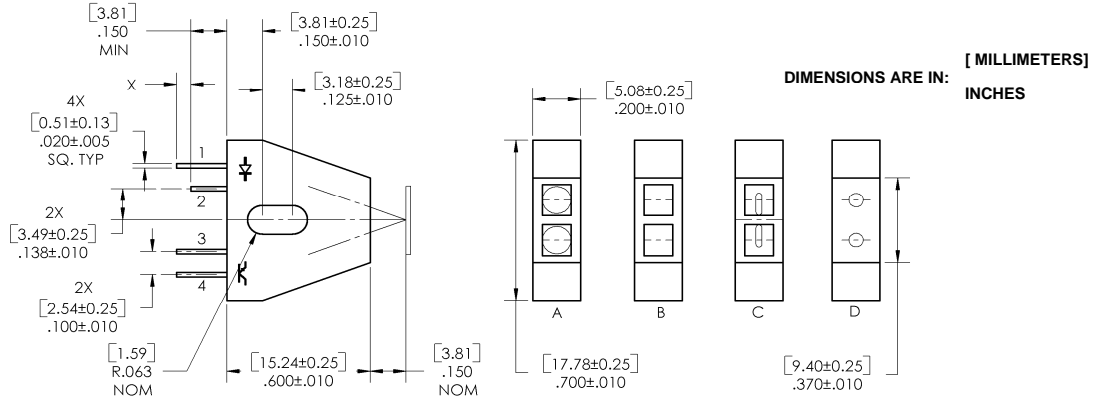

OPB740WZ, OPB741WZ, OPB742WZ, OPB743WZ,
OPB744WZ, OPB745WZ, OPB746WZ, OPB747WZ,
OPB748WZ

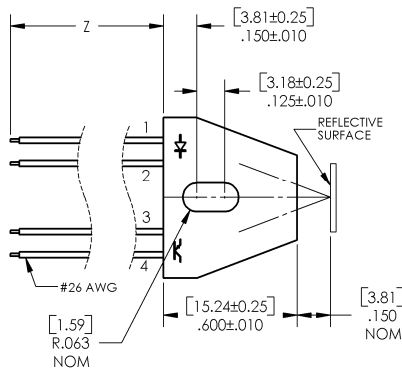

OPB708
OPB740 thru OPB744

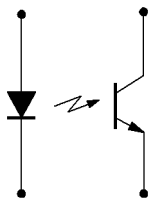

OPB746WZ,
OPB747WZ,

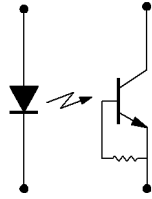

OPB709,
OPB745,

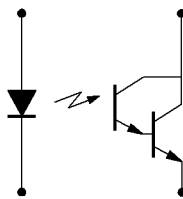

Color-PIN #	LED	Color-PIN #	Transistor
Orange-1	Anode	White-4	Collector
Green-2	Cathode	Blue-3	Emitter

Package Style	
Part Number	Lens Configuration
OPB708	D - No windows
OPB709	D - No windows
OPB740	A - No windows
OPB740WZ	A - No windows
OPB741	B - Blue windows
OPB741WZ	B - Blue windows
OPB742	C - Offset windows
OPB742WZ	C - Offset windows
OPB743	A - No windows
OPB743WZ	A - No windows
OPB744	B - Blue windows
OPB744WZ	B - Blue windows
OPB745	C - Offset windows
OPB745WZ	C - Offset windows
OPB746WZ	B - Blue windows
OPB747WZ	C - Offset windows
OPB748WZ	C - Offset windows

OPTEK reserves the right to make changes at any time in order to improve design and to supply the best product possible.

Reflective Object Sensor
OPB708, OPB709
OPB740 Series, OPB740WZ Series



Absolute Maximum Ratings ($T_A=25^\circ\text{C}$ unless otherwise noted)

Operating and Storage Temperature Range OPB708, OP709, OPB740, OPB741, OPB742, OPB743, OPB744, OPB745	-40° C to +85° C
OPB741WZ, OPB742WZ, OPB743WZ, OPB744WZ, OPB745WZ, OPB746WZ, OPB747WZ, OPB748WZ	-40° C to +80° C
Lead Soldering Temperature [1/16 inch (1.6mm) from the case for 5 sec. with soldering iron] ⁽¹⁾	260° C

Input Diode (See OP165 (935 nm), OP265 (890 nm) or OVLAS6CB8 (645 nm) for additional information)

Forward DC Current	40 mA
Reverse DC Voltage	2 V
Power Dissipation ⁽²⁾	100 mW

Sensor Output (See OP505 (Transistor), OP705 (R_{BE} Transistor) or OP535 (Darlington) for additional information)

Collector-Emitter Voltage OPB708 OPB709 OPB740, OPB741, OPB742, OPB743, OPB744 OPB740WZ, OPB741WZ, OPB742WZ, OPB743WZ, OPB744WZ, OPB748WZ OPB745 OPB745WZ OPB746WZ, OPB747WZ	30 V 15 V 30 V 30 V 15 V 15 V 24 V
Emitter-Collector Voltage OPB708 through OPB745, OPB748 OPB746 through OPB747	5.0 V 0.4 V
Power Dissipation ⁽²⁾	100 mW

Notes:

1. RMA flux is recommended. Duration can be extended to 10 seconds maximum when flow soldering.
2. Derate linearly 1.33 mW° C above 25° C.

Electrical Characteristics ($T_A = 25^\circ\text{C}$ unless otherwise noted)

SYMBOL	PARAMETER	MIN	TYP	MAX	UNITS	TEST CONDITIONS
--------	-----------	-----	-----	-----	-------	-----------------

645 nm LED (See OVLAS6CB8 for generic information — for reference only)

V_F	Forward Voltage	-	-	2.6	V	$I_F = 20\text{ mA}$
I_R	Reverse Current	-	-	100	μA	$V_R = 2\text{ V}$

890 nm LED (See OP265 for additional information — for reference only)

V_F	Forward Voltage	-	-	1.8	V	$I_F = 40\text{ mA}$
I_R	Reverse Current	-	-	100	μA	$V_R = 2\text{ V}$

935 nm LED (See OP165 for additional information — for reference only)

V_F	Forward Voltage	-	-	1.7	V	$I_F = 40\text{ mA}$
I_R	Reverse Current	-	-	100	μA	$V_R = 2\text{ V}$

OPTEK reserves the right to make changes at any time in order to improve design and to supply the best product possible.

Reflective Object Sensor
OPB708, OPB709
OPB740 Series, OPB740WZ Series



Electrical Characteristics ($T_A = 25^\circ\text{C}$ unless otherwise noted)

SYMBOL	PARAMETER	MIN	TYP	MAX	UNITS	TEST CONDITIONS
--------	-----------	-----	-----	-----	-------	-----------------

Output R_{BE} Phototransistor (See OP705 for general information — for reference only)

$V_{(BR)CEO}$	Collector-Emitter Breakdown Voltage	24	-	-	V	$I_C = 100 \mu\text{A}$
I_{CEO}	Collector Dark Current	-	-	100	nA	$V_{CE} = 10 \text{ V}, I_F = 0, E_E = 0$

Output Phototransistor (See OP505 for general information — for reference only)

$V_{(BR)CEO}$	Collector-Emitter Breakdown Voltage	30	-	-	V	$I_C = 100 \mu\text{A}$
$V_{(BR)ECO}$	Emitter-Collector Breakdown Voltage	5	-	-	V	$I_E = 100 \mu\text{A}$
I_{CEO}	Collector Dark Current	-	-	100	nA	$V_{CE} = 10 \text{ V}, I_F = 0, E_E = 0$

Output Photodarlington (See OP535 for general information — for reference only)

$V_{(BR)CEO}$	Collector-Emitter Breakdown Voltage	15	-	-	V	$I_C = 100 \mu\text{A}$
$V_{(BR)ECO}$	Emitter-Collector Breakdown Voltage	5	-	-	V	$I_E = 100 \mu\text{A}$
I_{CEO}	Collector-Emitter Dark Current OPB709, OPB745, OPB745WZ	-	-	25	μA	$V_{CE} = 5 \text{ V}, I_F = 0, E_E = 0$

Coupled

$V_{CE(SAT)}$	Saturation Voltage OPB708 OPB709	- -	- -	0.40 1.10	V	$I_F = 40 \text{ mA}, I_C = 3 \mu\text{A}, d = 0.15^{(1)(2)}$
$I_{C(ON)}^{(1)(2)}$	On-State Collector Current OPB708 OPB709 OPB740, OPB740WZ OPB741, OPB741WZ OPB742, OPB742WZ OPB743, OPB743WZ OPB744, OPB744WZ OPB745, OPB745WZ OPB746WZ OPB747WZ OPB748WZ	0.01 1.00 0.05 0.05 0.01 0.20 0.20 5.00 0.50 0.01 0.01	- - - - - - - - - - -	3.00 - 2.50 2.50 0.70 2.00 2.00 26.0 2.50 0.70 0.70	mA	$V_{CE} = 5 \text{ V}, I_F = 40 \text{ mA}, d = 0.15'' (3.810 \text{ mm})$
$I_{CX}^{(3)}$	Crosstalk OPB708, OPB709, OPB740, OPB740WZ OPB741, OPB741WZ OPB742, OPB742WZ OPB743, OPB743WZ OPB744, OPB744WZ OPB745, OPB745WZ OPB746WZ OPB747WZ OPB748WZ	- - - - - - - - - - -	- - - - - - - - - - -	- 10.0 10.0 1.0 20.0 20.0 25.0 1.0 1.0 1.0	μA	$V_{CC} = 5 \text{ V}, I_F = 40 \text{ mA}$

Notes:

- The distance from the assembly face to the reflective surface is "d".
- Reflective surface is Eastman Kodak (Catalog #190 3061) neutral white test card with 90% diffuse reflectance as a reflecting surface.
- Crosstalk is the photocurrent measured with current to the input diode, no reflective surface and no ambient light ($E_E = 0$).

OPTEK reserves the right to make changes at any time in order to improve design and to supply the best product possible.

Transistor Output vs Distance

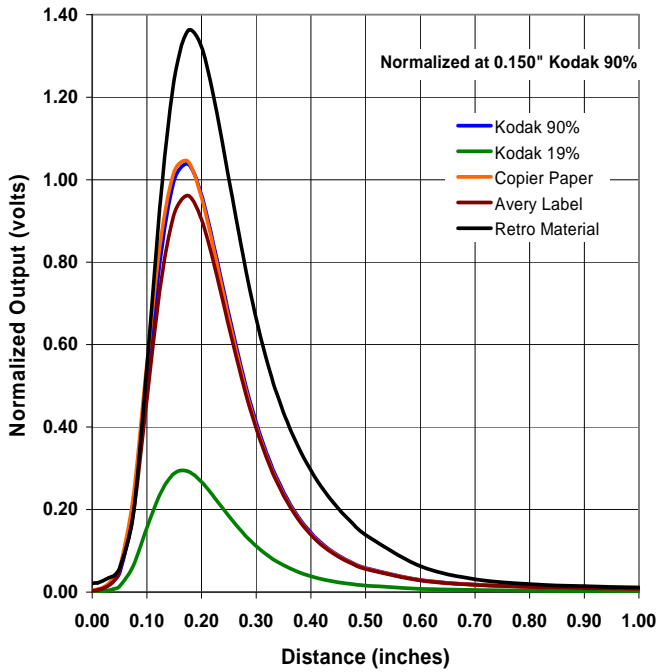

LED Forward Voltage vs Forward Current vs Temperature

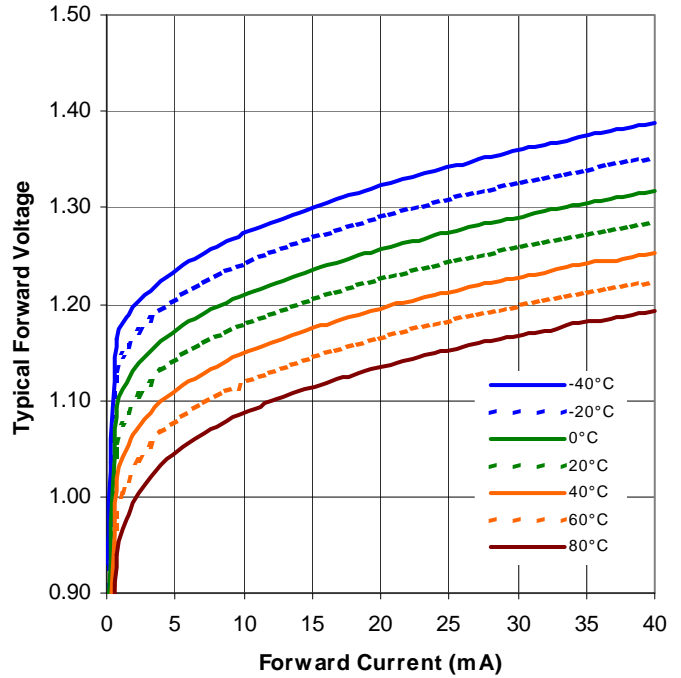

Transistor Output vs Forward Current vs Temperature

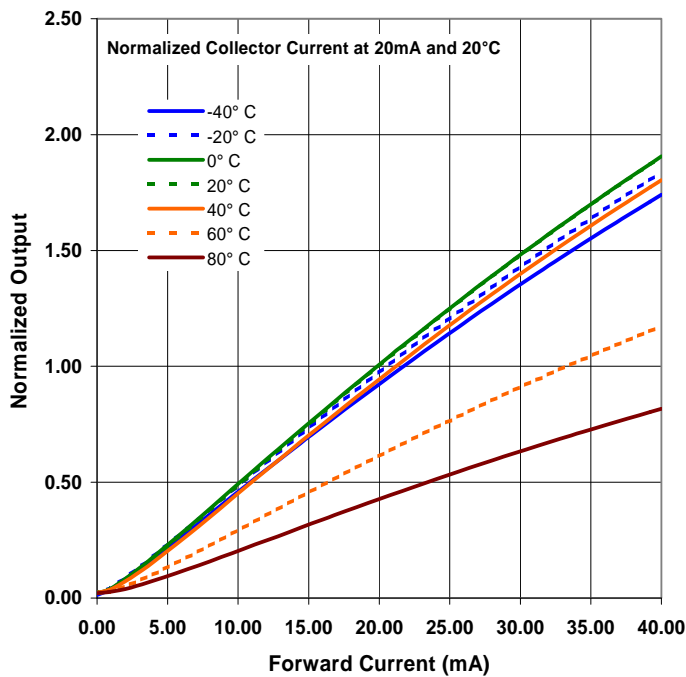

OPTEK reserves the right to make changes at any time in order to improve design and to supply the best product possible.

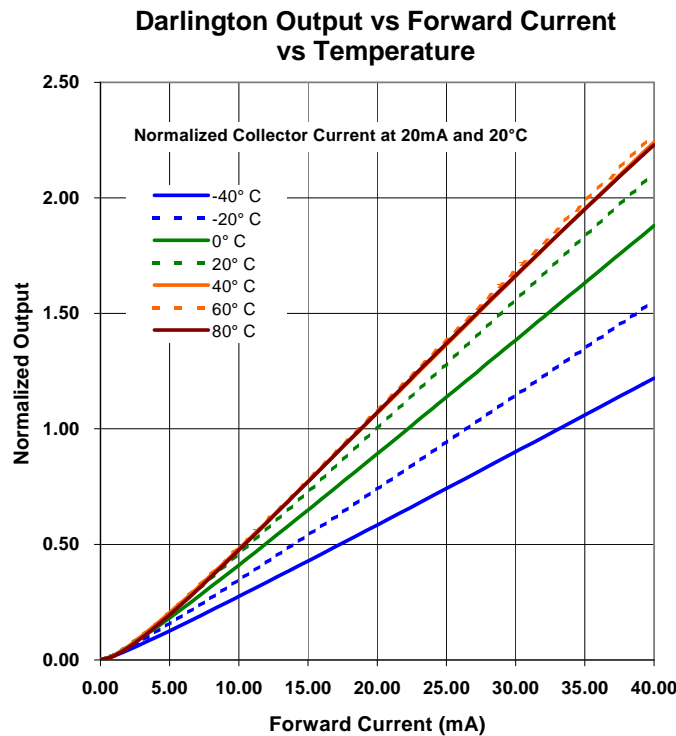
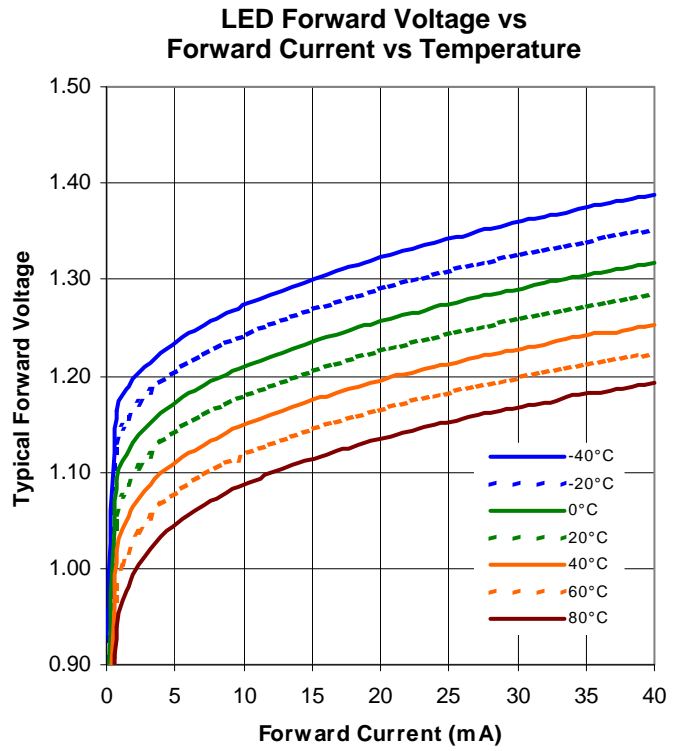
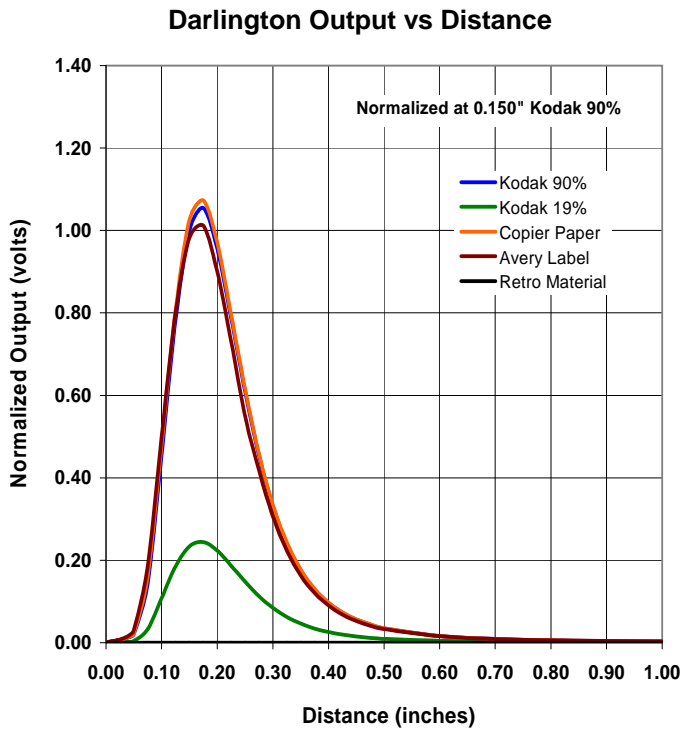

OPTEK reserves the right to make changes at any time in order to improve design and to supply the best product possible.

Mouser Electronics

Authorized Distributor

Click to View Pricing, Inventory, Delivery & Lifecycle Information:

Optek:

[OPB740W](#) [OPB741W](#) [OPB742W](#) [OPB743W](#) [OPB744W](#) [OPB745W](#) [OPB740WZ](#) [OPB741WZ](#) [OPB743WZ](#)
[OPB746WZ](#) [OPB747WZ](#) [OPB748WZ](#)

TT electronics:

[OPB742](#) [OPB745](#) [OPB742WZ](#) [OPB744WZ](#) [OPB745WZ](#) [OPB740](#) [OPB741](#) [OPB743](#) [OPB708](#) [OPB709](#) [OPB744](#)