

Pin Configuration

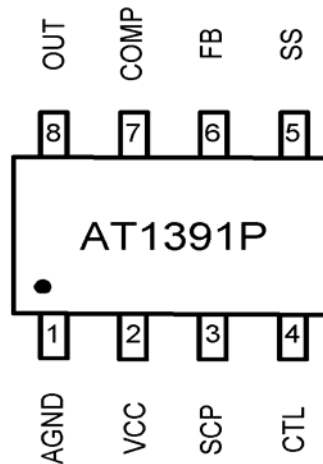

Ordering Information

Part number	Package	Marking
AT1391P	TSSOP8	AT1391P
AT1391P_GRE	TSSOP8, Green	AT1391P, date code with one bottom line

**For more marking information, contact our sales representative directly*

Pin Description

Symbol	Pin No.	Descript	Symbol	Pin No.(A/B)	Descript
GND	1	Control blocks ground	SS	5	Sotf-start
VCC	2	Power blocks power supply	FB	6	Error amplifier inverting input
SCP	3	Short-Circuit protection	COMP	7	Error amplifier output
CTL	4	Chip enable, high active	OUT	8	Output for Pch-MOSFET

Absolute Maximum Ratings^{*1}

Parameter	Condition	Rated Value		Unit
		Min.	Max.	
Power Supply Voltage	—	-	+7	V
Source Average Current of OUT	—	-	-50	mA
Sink Average Current of OUT	—	-	50	mA
Source Peak Current of OUT	—	-	-200	mA
Sink Peak Current of OUT	—	-	200	mA
Input Voltage to Error Amplifier	—	-	6.5	V
Continuous power dissipation	TSSOP8 (T _a =+25°C)	-	500	mW
Operating temperature	—	-30	+85	°C
Storage temperature	—	-55	+125	°C
ESD Susceptibility *2	HBM	2		KV
	MM	200		V

1. Stresses beyond those listed under “Absolute Maximum Ratings” may cause permanent damage to the device. These are stress ratings only, and functional operation of the device at these or any other conditions beyond those indicated in the operational sections of the specifications is not implied. Exposure to absolute maximum rating conditions for extended periods may affect device reliability.
2. Device are ESD sensitive. Handling precaution recommended. The Human Body model is a 100pF capacitor discharged through a 1.5KΩ resistor into each pin

Recommended Operating Conditions

(T_a=+25°C)

Parameter	Symbol	Values			Unit
		Min.	Typ.	Max.	
Power supply voltage	V _{CC}	2.5	--	6	V
Control input voltage	V _{CTL}	0	--	6	V
Operating temperature	T _{OP}	-20	+25	+85	°C

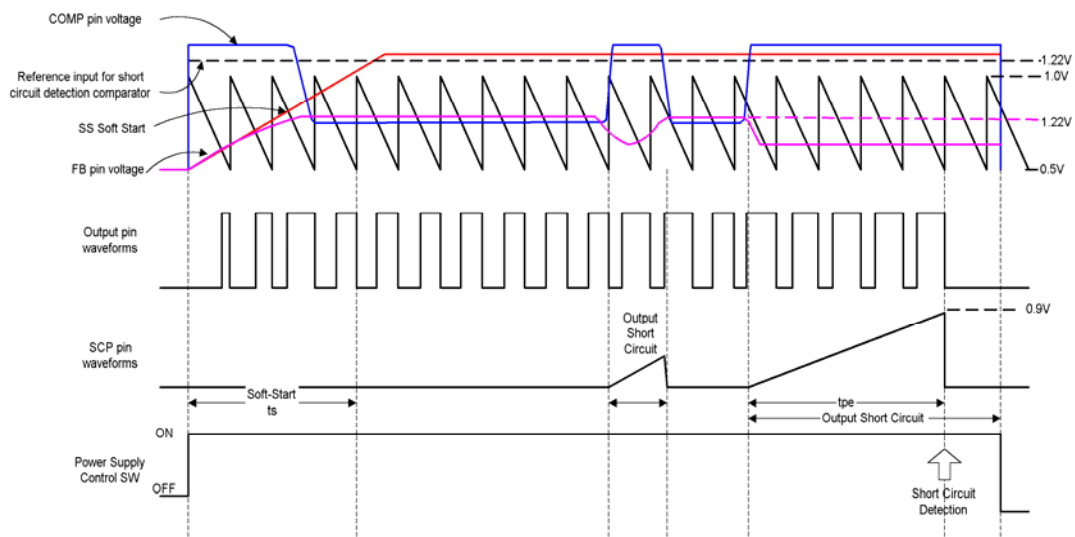

Electrical Characteristics

(VCC = 5V, Ta = +25°C , unless otherwise noted.)

Parameter	Symbol	Condition	Values			Unit		
			Min.	Typ.	Max.			
Entire device	Input Supply Range	V _{CC}	2.5	--	6.0	V		
	Quiescent Current	I _{CC}	Duty=50%, f _{OSC} =600KHz PDRV/NDRV No Load		1.0	1.5	mA	
	Current in standby mode	I _{ST}	CTL=0V			10	μA	
	Reference Voltage	V _{REF}	Ta = -20°C to +85°C		1.20	1.22	1.24	V
	Reference Voltage line-regulation	V _{REF-Line}	VCC=2.5V to 6.0V			1	5	mV
	Reference Variation with Temperature		Ta = -20°C to +85°C			0.5	1.5	%
Error amplifier	Input Offset Voltage	V _{IO}				10	mV	
	Source Current	I _{OH}	V _{COMP} = V _{REF} - 0.5V		-1.0	-1.5	-2.0	mA
	Sink Current	I _{OL}	V _{COMP} = 0.5V		160	120	80	μA
	Source current Variation with temperature		Ta = -20°C to +85°C				20	%
	Sink current Variation with temperature		Ta = -20°C to +85°C				20	%
	Unity Gain Bandwidth	f _T				10.0		MHz
	Common Mode Input Voltage Range	V _{COM}			0.2		1.5	V
	DC Open Loop Gain	A _V				110		dB
Sawtooth wave oscillator (OSC)	Frequency	f _{osc}	500	600	700		KHz	
	High Level Voltage			1.0			V	
	Low Level Voltage			0.5			V	
	Variation with Power Supply		Vcc=2.5V to 6V				2	%
	Variation with temperature		Ta = -20°C to +85°C				7	%
Soft-Start	Charge Current of SS	I _{CSS}		-1.0			μA	
	Invalid threshold voltage of SS			1.0			V	
Short-Circuit	Charge Current of SS	I _{CSCP}	-1.5	-1.25	-1.0		μA	
	Threshold Voltage of SCP		0.8	0.9	1.0		V	
	Output source current	I _{source}	Duty ≥ 95% OUT = 0V		-	-130	-80	mA

Output Block	Output sink current	I_{sink}	Duty \leq 5% OUT=5V	65	100		mA
	Output ON resistor	R_{OH}	OUT=-15mA		18	30	Ω
		R_{OL}	OUT=15mA			16	25
Control Block	CTL input voltage	V_{IH}	Active mode	2.0		VCC	V
		V_{IL}	Standby mode	0		0.5	V
	CTL input Current	I_{CTL}	CTL=5.0V				20

Application Circuit

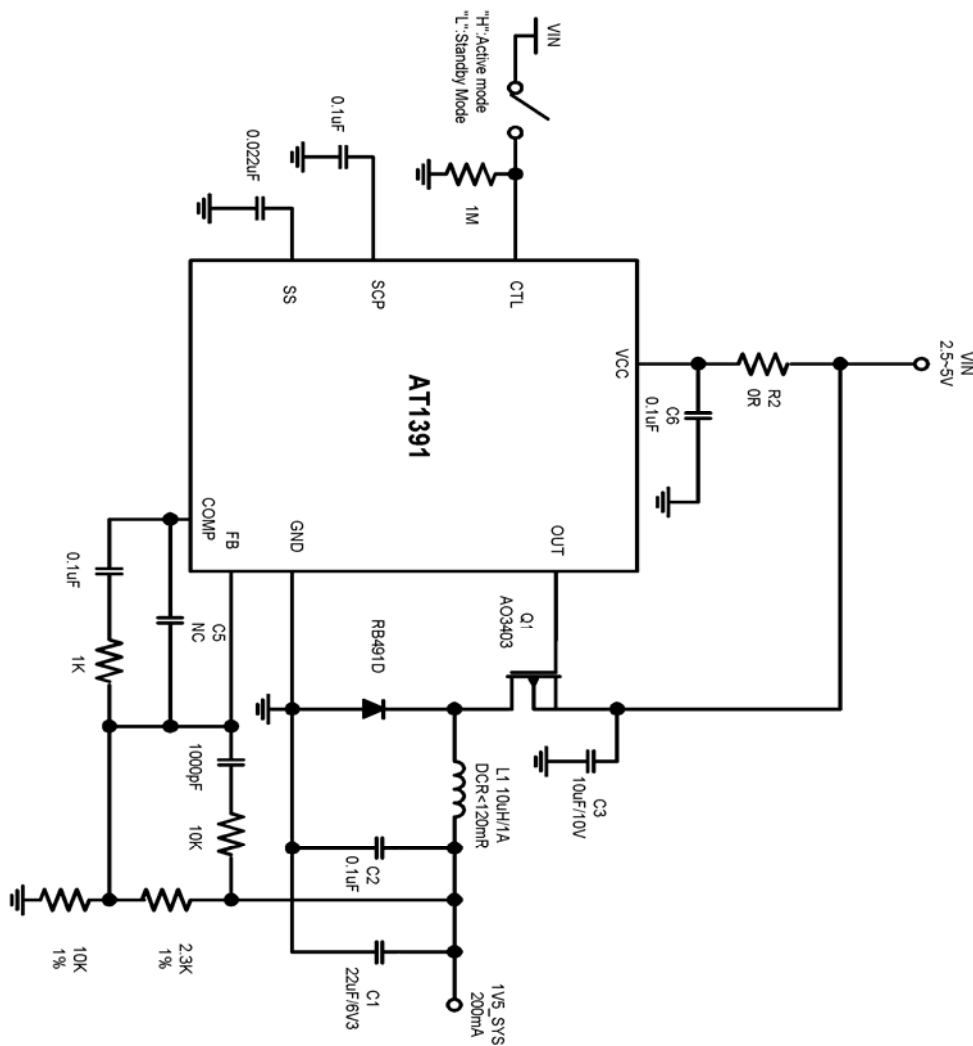

AT1391 Efficiency

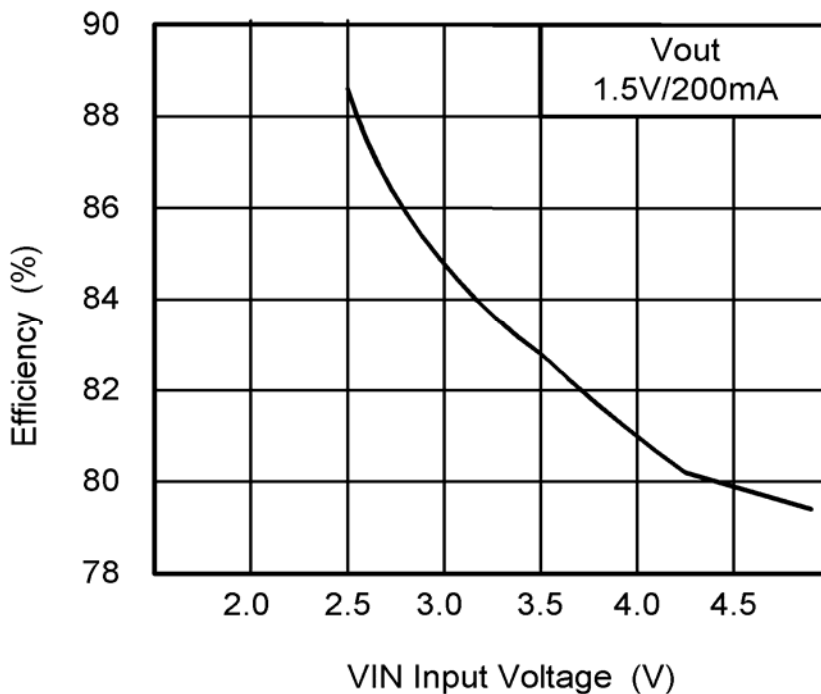

AT1391 Efficiency

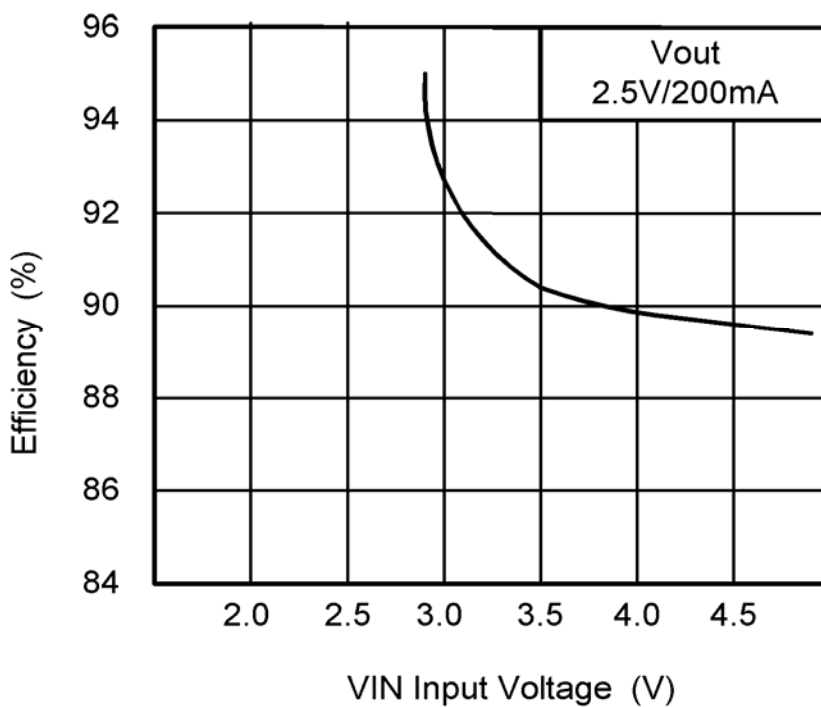

AT1391 Efficiency

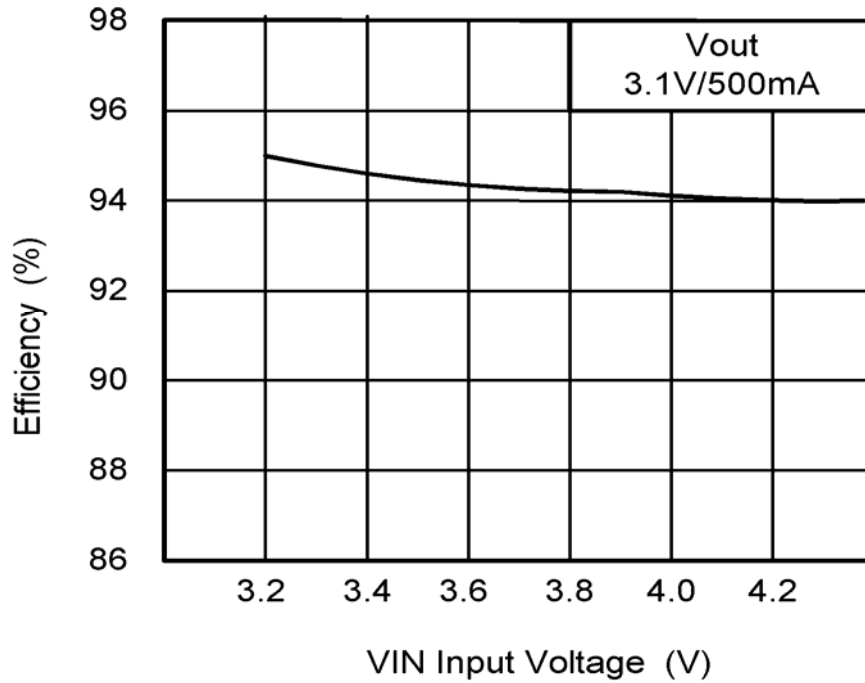

Small Outline 8-pin TSSOP

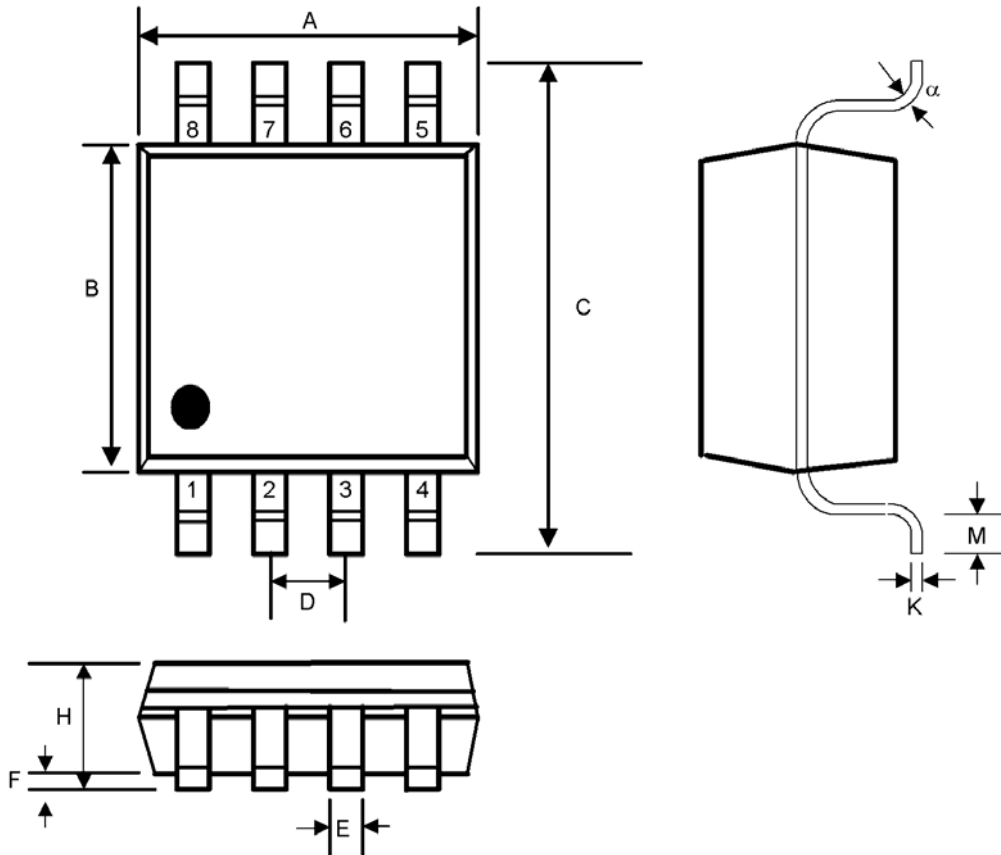

SYMBOL	INCHES		MILLIMETERS		NOTES
	MIN	MAX	MIN	MAX	
A	0.114	0.122	2.90	3.10	-
B	0.169	0.177	4.30	4.50	-
C	0.244	0.260	6.20	6.60	-
D	0.026	BSC	0.65	BSC	-
E	0.010	0.012	0.25	0.30	-
F	0.002	0.006	0.05	0.15	-
H	0.041	0.047	1.05	1.20	-
K	0.005	BSC	0.127	BSC	-
M	0.020	0.028	0.50	0.70	-
α	0°	8°	0°	8°	-

Reflow Condition (IR/Convection or VPR Reflow)

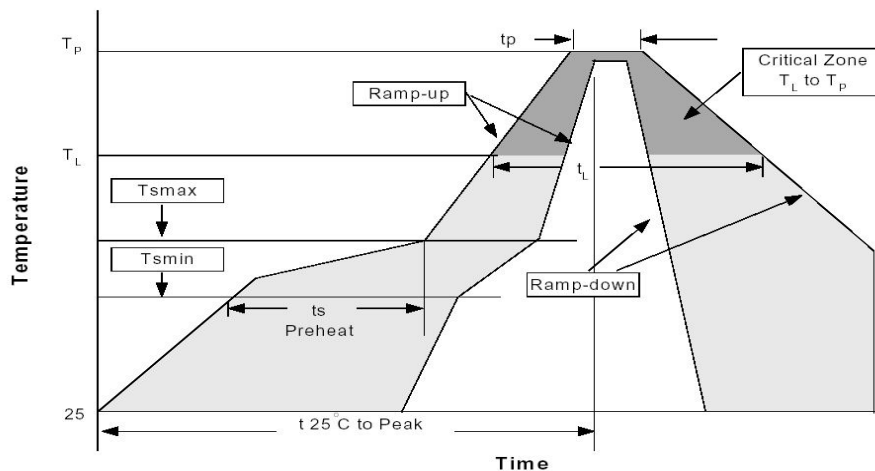

Classification Reflow Profiles

Profile Feature	Sn-Pb Eutectic Assembly	Pb-Free Assembly
Average ramp-up rate (T _L to T _P)	3°C/second max.	3°C/second max.
Preheat		
-Temperature Min(T _{min})	100°C	150°C
-Temperature Max (T _{max})	150°C	200°C
-Time (min to max)(t _s)	60-120 seconds	60-180 seconds
Time maintained above:		
-Temperature (T _L)	183°C	217°C
-Time (t _L)	60-150 seconds	60-150 seconds
Peak/Classification Temperature(T _P)	See table 1	See table 2
Time within 5°C of actual Peak Temperature (t _p)	10-30 seconds	10 seconds max.
Ramp-down Rate	6°C/second max.	6°C/second max.
Time 25°C to Peak Temperature	6 minutes max.	8 minutes max.

*All temperatures refer to topside of the package, measured on the package body surface.

Classification Reflow Profiles(Cont.)

Table 1. SnPb Entectic Process - Package Peak Reflow Temperatures

Package Thickness	Volume mm ³ <350	Volume mm ³ ≥350
<2.5mm	240+0/-5°C	225+0/-5°C
≥2.5mm	225+0/-5°C	225+0/-5°C

Table 2. Pb-free Process - Package Classification Reflow Temperatures

Package Thickness	Volume mm ³ <350	Volume mm ³ 350-2000	Volume mm ³ >2000
<1.6mm	260+0°C	260+0°C	260+0°C
1.6mm - 2.5mm	260+0°C	250+0°C	245+0°C
≥2.5mm	250+0°C	245+0°C	245+0°C

*Tolerance: The device manufacturer/supplier shall assure process compatibility up to and including the stated classification temperature (this means Peak reflow temperature +0°C. For example 260°C+0°C) at the rated MSL level.