

Features and Benefits

Triaxis® Hall Technology
 On Chip Signal Processing for Robust Absolute Position Sensing
 Simple Magnetic Design
 Programmable Measurement Range
 Programmable Linear Transfer Characteristic (Multi-points)
 SENT output (according to SAE J2716-2010)
 12 bit Resolution - 10 bit Thermal Accuracy
 48 bit ID Number option
 Robust Dual Mold Package (DMP) feat. 4 Decoupling Capacitors (ESD/EMC)
 Reliable NoPCB Module Integration

Applications

Absolute Rotary Position Sensor	Absolute Linear Position Sensor
Pedal Position Sensor	Steering Wheel Position Sensor
Throttle Position Sensor	Float-Level Sensor
Ride Height Position Sensor	Non-Contacting Potentiometer

Ordering Information¹

Part No.	Temperature Code	Package Code	Option Code	Packing Code
MLX90366	L	VS	ADS-250	RE
MLX90366	L	VS	ADS-250	RX
MLX90366	L	VS	ADS-250	TU
MLX90366	L	VS	ADS-251	RE
MLX90366	L	VS	ADS-251	RX
MLX90366	L	VS	ADS-253	RE
MLX90366	L	VS	ADS-253	RX

Legend:

Temperature Code: L for Temperature Range - 40°C to 150°C,
 Package Code: VS for DMP-4
 Option Code: **AAA-123:**
 AAA: die version
 1: IMC placement
 2: Output capacitor
 • 0: 100nF (not selectable for this product)
 • 5: 10nF
 3: Trim and form option:
 • 0: Standard (straight leads) see section 20.1
 • 1: Trim and Form STD1 2.54 see section 20.2
 • 3: Trim and Form STD2 2.54 see section 20.3
 Packing Form: RE for Reel (face-up)
 RX for Reel (face down)
 TU for Tube

Ordering Example: MLX90366LVS-ADS-250-RE

¹ See your sales representative for more details.

1. Functional Diagram

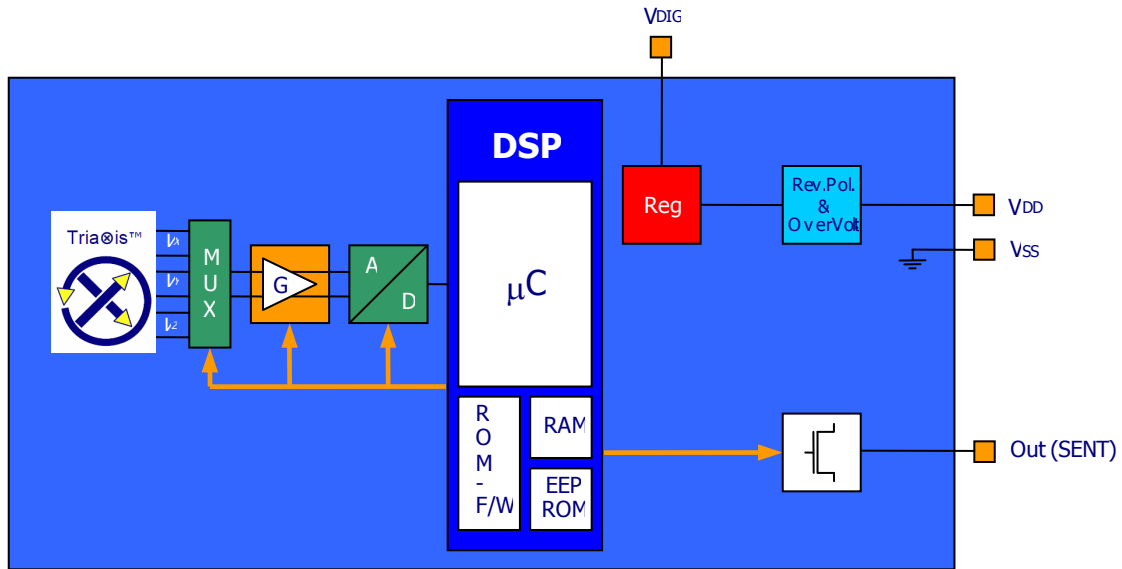

Figure 1 - MLX90366 Block Diagram

2. Description

The MLX90366 Triaxis® Position Sensor Assembly is a high accuracy linear and angular position sensor which eliminates need for inclusion of a printed circuit board (PCB) within sensing modules.

This device is based on a Dual Mold Package (DMP) construction, which integrates a Triaxis position sensing die together with the decoupling capacitors necessary to meet the strenuous ESD and EMC requirements. No PCB is needed.

The Triaxis® Position Sensing Die is nothing but the one used for the MLX90367 in conventional surface-mount packages (SOIC-8 – single die & TSSOP-16 – dual die).

The decoupling capacitors are X8R capacitors well suited for package integration and the target operating temperature range.

The MLX90366 is sensitive to the three components of the flux density applied to the IC (i.e. B_x , B_y and B_z). This allows the MLX90366 with the correct magnetic circuit to decode the absolute position of any moving magnet (e.g. rotary position from 0 to 360 Degrees or linear displacement, stroke - Figure 2). It enables the design of novel generation of non-contacting position sensors that are frequently required for both automotive and industrial applications.

MLX90366 provides SENT Frames encoded according the Secure Sensor format. The circuit delivers enhanced serial messages providing error codes, and user-defined values.

MLX90366 Triaxis® Position Sensor Assembly enables the realization of position sensor modules for which a PCB is no longer needed: this yield to an increase of the electrical, mechanical and environmental robustness of the final application.



TABLE of CONTENTS

FEATURES AND BENEFITS	1
APPLICATIONS	1
ORDERING INFORMATION	1
1. FUNCTIONAL DIAGRAM	2
2. DESCRIPTION	3
3. GLOSSARY OF TERMS – ABBREVIATIONS – ACRONYMS	6
4. PINOUT	6
5. ABSOLUTE MAXIMUM RATINGS	7
6. DESCRIPTION	7
7. MLX90366 ELECTRICAL SPECIFICATION	9
8. MLX90366 TIMING SPECIFICATION	10
8.1. TIMING DIAGRAMS.....	11
8.2. APPLICATION DIAGRAM USED FOR RISE AND FALL TIME MEASUREMENT.....	12
9. MLX90366 ACCURACY SPECIFICATION	13
10. MLX90366 MAGNETIC SPECIFICATION	14
11. MLX90366 CPU & MEMORY SPECIFICATION.....	14
12. MLX90366 END-USER PROGRAMMABLE ITEMS	15
13. SENT OUTPUT PROTOCOL.....	16
13.1. GENERALITY.....	16
13.2. SINGLE SECURE FAST CHANNEL.....	16
13.2.1. <i>Frame Content</i>	16
13.2.2. <i>Diagnostic Reporting through the fast channel</i>	16
13.2.3. <i>Pause pulse</i>	17
13.2.4. <i>Fast Channel CRC</i>	17
13.3. SLOW CHANNEL.....	17
13.3.1. <i>Enhanced Serial Message</i>	17
13.3.2. <i>Serial Message Sequence</i>	18
13.3.3. <i>Serial message sequence period</i>	19
13.3.4. <i>Serial Message Error Code</i>	19
13.4. START-UP.....	20
13.5. FIELD SENSING (ADC CONVERSIONS) AND THE FRAME SYNCHRO PULSE	20
14. DESCRIPTION OF END-USER PROGRAMMABLE ITEMS	21
14.1. OUTPUT TRANSFER CHARACTERISTIC.....	21
14.1.1. <i>CLOCKWISE Parameter</i>	21
14.1.2. <i>Discontinuity Point (or Zero Degree Point)</i>	22
14.1.3. <i>17-Pts LNR Parameters</i>	22
14.1.4. <i>CLAMPING Parameters</i>	23
14.2. IDENTIFICATION.....	23
14.3. SENSOR FRONT-END.....	23
14.3.1. <i>MAPXYZ</i>	24
14.3.2. <i>SMISM, k and SEL_k Parameters</i>	24
14.3.3. <i>GAINMIN and GAINMAX Parameters</i>	24
14.4. FILTER.....	25
14.5. DIAGNOSTIC FEATURES.....	25
14.6. EEPROM ENDURANCE	25

15. MLX90366 SELF DIAGNOSTIC	26
16. BUILT-IN CAPACITORS	27
17. STANDARD INFORMATION REGARDING MANUFACTURABILITY OF MELEXIS PRODUCTS WITH DIFFERENT LEAD PRE-FORMING AND SOLDERING/WELDING PROCESSES	27
18. ESD PRECAUTIONS	27
19. PACKAGE INFORMATION	28
19.1. DMP-4 – PACKAGE OUTLINE DIMENSIONS (POD) – STRAIGHT LEADS.....	28
19.2. DMP-4 – PACKAGE OUTLINE DIMENSIONS (POD) – TRIMMED & FORMED LEADS [1].....	29
19.3. DMP-4 – PACKAGE OUTLINE DIMENSIONS (POD) – TRIMMED & FORMED LEADS [2].....	30
19.4. DMP-4 - MARKING.....	31
19.5. DMP-4 - SENSITIVE SPOT POSITIONING & SENSE DIRECTION.....	32
20. DISCLAIMER	34

3. Glossary of Terms – Abbreviations – Acronyms

- Gauss (G), Tesla (T): Units for the magnetic flux density – 1 mT = 10 G
- TC: **T**emperature **C**oefficient (in ppm/Deg.C.)
- NC: **N**ot **C**onnected
- SENT: **S**ingle **E**dge **N**ibble **T**ransmission
- ADC: **A**nalog-to-**D**igital **C**onverter
- LSB: **L**east **S**ignificant **B**it
- MSB: **M**ost **S**ignificant **B**it
- DNL: **D**ifferential **N**on-**L**inearity
- INL: **I**ntegral **N**on-**L**inearity
- RISC: **R**educed **I**nstruction **S**et **C**omputer
- ASP: **A**nalog **S**ignal **P**rocessing
- DSP: **D**igital **S**ignal **P**rocessing
- CoRDIC: **C**oordinate **R**otation **D**igital **C**omputer (i.e. iterative rectangular-to-polar transform)
- EMC: **E**lectro-**M**agnetic **C**ompatibility

4. Pinout

Pin #	
1	VSS (Ground)
2	VDD
3	OUT
4	VSS (Ground)

5. Absolute Maximum Ratings

Supply Voltage, VDD (overvoltage)	+ 24 V
Reverse Voltage Protection	– 12 V (breakdown at -14 V)
Positive Output Voltage	+ 18 V (breakdown at 24 V)
Output Current (I _{OUT})	+ 30 mA (in breakdown)
Reverse Output Voltage	– 0.3 V
Reverse Output Current	– 50 mA (in breakdown)
Operating Ambient Temperature Range, T _A	– 40°C ... + 150°C
Storage Temperature Range, T _S	– 40°C ... + 150°C
Magnetic Flux Density	± 1 T

Exceeding the absolute maximum ratings may cause permanent damage. Exposure to absolute maximum rated conditions for extended periods may affect device reliability.

6. Description

As described on the block diagram the three vector components of the magnetic flux density (B_x, B_y and B_z) applied to the IC are sensed through the sensor front-end. The respective Hall signals (V_x, V_y and V_z) are generated at the Hall plates and amplified.

The analog signal processing is based on a fully differential analog chain featuring the classic offset cancellation technique (Hall plate 2-Phases spinning and chopper-stabilized amplifier).

The conditioned analog signals are converted through an ADC (15 bits) and provided to a DSP block for further processing. The DSP stage is based on a 16 bit RISC micro-controller whose primary function is the extraction of the position from two (out of three) raw signals (after so-called front-end compensation steps) through the following function:

$$\alpha = \angle(V_1, k \cdot V_2)$$

Where alpha is the magnetic angle $\angle(B_1, B_2)$, V₁ = V_x or V_y or V_z, V₂ = V_x or V_y or V_z and k is a programmable factor to match the amplitude of V₁ and k V₂.

The DSP functionality is governed by the micro-code (firmware – F/W) of the micro-controller which is stored into the ROM (mask programmable). In addition to the magnetic angle extraction, the F/W controls the whole analog chain, the output transfer characteristic, the output protocol, the programming/calibration and also the self-diagnostic modes.

The magnetic angular information is intrinsically self-compensated vs. flux density variations. This feature allows therefore an improved thermal accuracy vs. position sensor based on conventional linear Hall sensors.

In addition to the improved thermal accuracy, the realized position sensor features excellent linearity performance taking into account typical manufacturing tolerances (e.g. relative placement between the Hall IC and the magnet).

Once the position (angular or linear stroke) information is computed, it is further conditioned (mapped) vs. the target transfer characteristic and it is provided at the output(s) as SENT output.

The linear part of the transfer curve can be adjusted through a multi-point calibration:

This back-end step consists of a Piece-Wise-Linear (PWL) output transfer characteristic - 17 equidistant points with programmable origin over 16 different angle ranges from 65 to 360 degrees.

The calibration parameters are stored in EEPROM featuring a Hamming Error Correction Coding (ECC).

The programming steps do not require any dedicated pins. The operation is done using the supply and output nodes of the IC. The programming of the MLX90366 is handled at both engineering lab and production line levels by the Melexis Programming Unit PTC-04 with the daughterboard DB90316 + dedicated MLX90367 software.

7. MLX90366 Electrical Specification

DC Operating Parameters at VDD = 5V (unless otherwise specified) and for T_A as specified by the Temperature suffix (L).

Parameter	Symbol	Test Conditions	Min	Typ	Max	Units
Nominal Supply Voltage	VDD		4.5	5	5.5	V
Supply Current ⁽²⁾	I _{dd}				10	mA
Isurge Current ⁽³⁾	I _{surge}				20	mA
Power-On reset (rising)	HPOR_LH	Refer to internal voltage Vdig	2	2.25	2.5	V
Power-On reset Hysteresis	HPOR_Hyst		50		200	mV
Start-up Level (rising)	MT4V_LH		3.8	4.0	4.2	V
Start-up Hysteresis	MT4V_Hyst		50		200	mV
PTC Entry Level (rising)	MT7V_LH		5.8	6.2	6.6	V
PTC Entry Level Hysteresis	MT7V_Hyst		50		200	mV
Output Short Circuit Current	I _{short}	Vout = 0 V			15	mA
		Vout = 5 V			15	mA
		Vout = 18 V (T _A = 25°C)			18	mA
Output Load	R _L	Pull-down to Ground	4.7	10	∞	kΩ
		Pull-up to 5V	4.7	10	∞	kΩ
Passive Diagnostic Output Level (Broken Track Diagnostic) ⁽⁴⁾	BVSSPD	Broken VSS & Pull-down load R _L ≥ 10 kΩ	97.5			% VDD
	BVSSPU	Broken VSS & Pull-up load R _L ≥ 4.7kΩ	99.5	100		% VDD
	BVDDPD	Broken VDD & Pull-down load R _L ≥ 4.7kΩ		0	0.5	% VDD
	BVDDPU	Broken VDD & Pull-up load R _L ≥ 5kΩ			2	% VDD

² For the dual version, the supply current is multiplied by 2.

³ The specified value is valid during early start-up time only; the current might dynamically exceed the specified value, shortly, during the Start-up phase. This current peak is linked a.o. to the charging of the integrated capacitors.

⁴ The SENT output signal will no longer be reported. For detailed information, see also section 15.

8. MLX90366 Timing Specification

DC Operating Parameters at VDD = 5V (unless otherwise specified) and for T_A as specified by the Temperature suffix (L).

Parameter	Symbol	Test Conditions	Min	Typ	Max	Units
Main Clock Frequency	Ck	All contributors (trimming accuracy, supply voltage, thermal and ageing)	12.6	13.3	14	MHz
Main Clock Frequency Thermal Drift	ΔT_{Ck}				$\pm 3\%$	Ck _{NOM}
Tick time		Exact value for Ck = 13.3 MHz The typical value will be affected by any variation of the clock		3		μs
SENT Frame Period	t _{frame}			882		μs
Internal Angle Measurement Period	t _{per}			441		μs
First Angle Measurement to Sync Pulse latency	t _{a1}				1084	μs
Second Angle Measurement to Sync Pulse latency	t _{a2}				643	μs
Field Change to SENT Data : Average Latency	Latency	FILTER = 1 (recommended) SENT Transmission Included	1745		1745	μs
SENT Frame Tick Count			294		294	
Watchdog	t _{wd}		114.5	118	121.5	ms
Start-up Time (up to first sync pulse)	t _{su1}			1.8		ms
Start-up Time (up to first data received)	t _{su2}	Last pause pulse not included		5.9	6.3	ms
Serial Message		Extended sequence (18 frames) Short sequence (8 frames)		15.876 7.056		ms
Rise Time @ Cable		Thresholds : 0.5V and 4.5V See section 8.2	2.97		5.31	μs
Rise Time @ Receiver			5.07		6.84	μs
Fall Time @ Cable			2.65		2.82	μs
Fall Time @ Receiver			4.84		4.9	μs

8.1. Timing diagrams

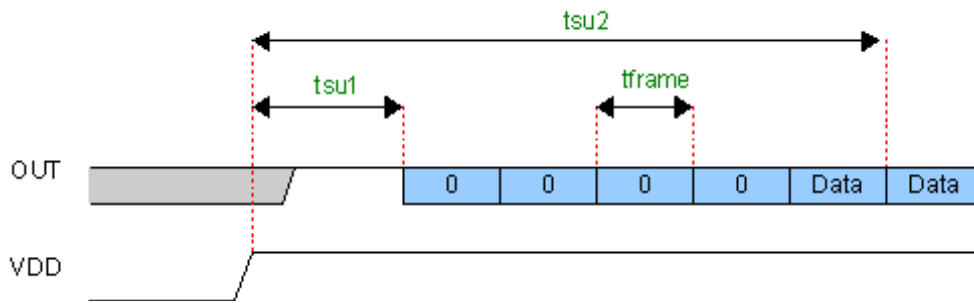

Figure 2 – Start-up phase timings

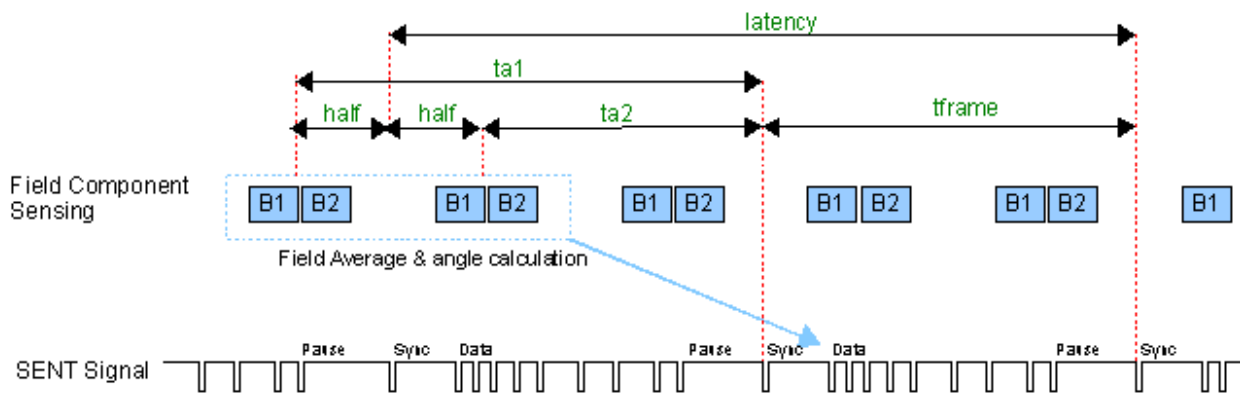

Figure 3a – Latencies (acquisition to output delays) – FILTER = 1 (recommended)

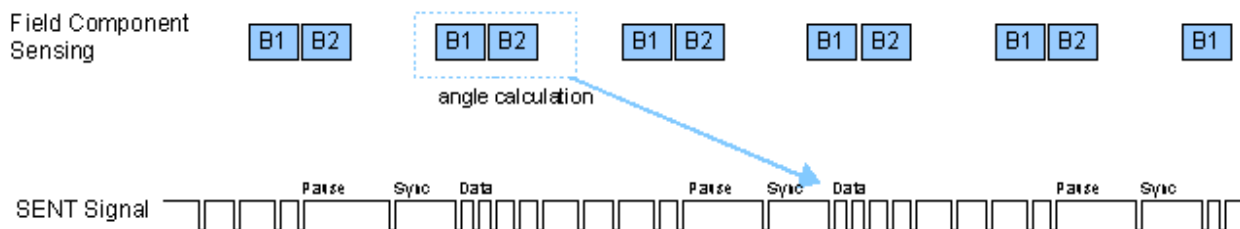

Figure 3b – Latency - Case FILTER = 0 (not recommended)

8.2. Application diagram used for rise and fall time measurement

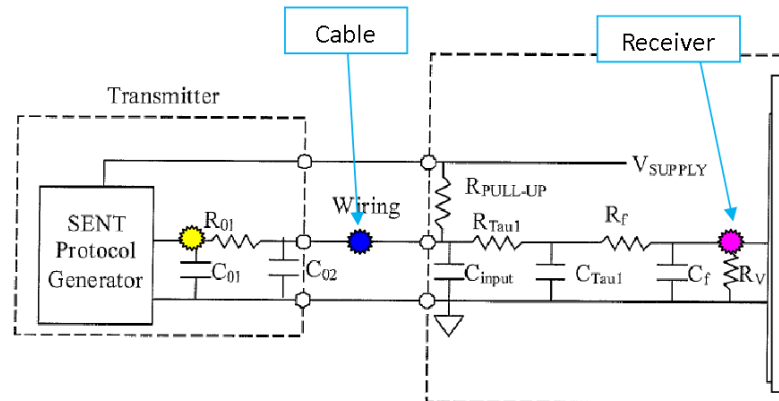

Figure 4 –Schematic used for rise and fall time measurements (ref: J2716 Rev Jan 2010 Fig. 6.3.4)

Component	Value	Unit
C01	10 (integrated in the DMP)	nF
C02	not mounted	nF
R01	not mounted	Ohms
Cinput	68	pF
CTau	2.2	nF
Cf	100	pF
RTau	568	Ohms
Rf	10	kOhms
RPU	14.7	kOhms
RV	not mounted	Ohms

Component values used for rise and fall time measurements (ref: J2716 Rev Jan 2010 Fig. 6.3.4)

9. MLX90366 Accuracy Specification

DC Operating Parameters at VDD = 5V (unless otherwise specified) and for T_A as specified by the Temperature suffix (L).

Parameter	Symbol	Test Conditions	Min	Typ	Max	Units
ADC Resolution on the raw signals sine and cosine ⁽⁵⁾	R _{ADC}			15		bits
Thermal Offset Drift #1 ⁽⁶⁾ at the DSP input (excl. DAC and output stage)		T _A from -40 to 125°C T _A from -40 to 150°C	-60 -90		+60 +90	LSB ₁₅
Thermal Drift of Sensitivity Mismatch ⁽⁷⁾		XY axis XZ (YZ) axis	- 0.5 -1		+ 0.5 +1	%
Magnetic Angle phase error		T _A = 25°C – XY axis T _A = 25°C – XZ axis T _A = 25°C – YZ axis	-0.3 -2 -2		0.3 2 2	Deg.
Thermal Drift of Magnetic Angle phase error		axis, XZ (YZ) axis		0.01		Deg.
XY – Intrinsic Linearity Error ⁽⁸⁾	Le	T _A = 25°C – factory trim. “SMISM”	-1		1	Deg
XZ - Intrinsic Lin. Error ⁽¹¹⁾	Le	T _A = 25°C – “k” trimmed for XZ	-2.5	±1.25	2.5	Deg
YZ - Intrinsic Lin. Error ⁽¹¹⁾	Le	T _A = 25°C – “k” trimmed for YZ	-2.5	±1.25	2.5	Deg
Noise pk-pk ⁽⁹⁾		FILTER = 0, 40mT FILTER = 1 (recommended) , 30mT		0.10 0.10	0.2 0.2	Deg

⁵ 16 bits corresponds to 15 bits + sign. Internal computation is performed using 16 bits.

⁶ For instance, in case of a rotary position sensor application, Thermal Offset Drift #1 equal ± 60LSB₁₅ yields to max. ± 0.3 Deg. angular error for the computed angular information (output of the DSP). This is only valid if k = 1. “MLX90365 Front-End Application Note” will be released for more details.

⁷ For instance, in case of a rotary position sensor application, Thermal Drift of Sensitivity Mismatch equal ± 0.5% yields to max. ± 0.15 Deg. angular error for the computed angular information (output of the DSP). See “MLX90365 Front-End Application Note” for more details.

⁸ The Intrinsic Linearity Error refers to the IC itself (offset, sensitivity mismatch, orthogonality) taking into account an ideal rotating field for B_X and B_Y. Once associated to a practical magnetic construction and the associated mechanical and magnetic tolerances, the output linearity error increases. However, it can be improved with the multi-point end-user calibration. The intrinsic Linearity Error for Magnetic angle ∠XZ and ∠YZ can be reduced through the programming of the k factor.

⁹ Noise pk-pk (peak-to-peak) is here intended as 6 times the Noise standard Deviation. The application diagram used is described in the recommended wiring. For detailed information, refer to section Filter in application mode (Section 14.4).

10. MLX90366 Magnetic Specification

DC Operating Parameters at VDD = 5V (unless otherwise specified) and for TA as specified by the Temperature suffix (L).

Parameter	Symbol	Test Conditions	Min	Typ	Max	Units
Magnetic Flux Density	B _X , B _Y ⁽¹⁰⁾	$\sqrt{B_X^2 + B_Y^2}$			70 ⁽¹¹⁾	mT
Magnetic Flux Density	B _Z ⁽¹²⁾				126	mT
Magnetic Flux Norm	Norm	$\sqrt{B_X^2 + B_Y^2 + (B_Z/1.15)^2}$	20 ⁽¹²⁾			mT
IMC Gain ⁽¹³⁾	GainIMC		1.15	1.3	1.4	
Magnet Temperature Coefficient	TCm		-2400		0	ppm/°C

11. MLX90366 CPU & Memory Specification

The DSP is based on a 16 bit RISC μ Controller. This CPU provides 2.5 Mips while running at 10 MHz.

Parameter	Symbol	Test Conditions	Min	Typ	Max	Units
ROM				10		KB
RAM				384		B
EEPROM				128		B

¹⁰ The condition must be fulfilled for at least one field BX or BY.

¹¹ Above 70 mT, the IMC® starts saturating yielding to an increase of the linearity error.

¹² Below 20 mT, the performances slightly degrade due to a reduction of the signal-to-noise ratio, signal-to-offset ratio.

¹³ This is the magnetic gain linked to the Integrated Magneto Concentrator (IMC®) structure. It applies to BX and BY and not to BZ. This is the overall variation. Within one lot, the part to part variation is typically $\pm 10\%$ versus the average value of the IMC® gain of that lot

12. MLX90366 End-User Programmable Items

Parameter	Comments	Standard	# bit
MAPXYZ	Mapping fields for output angle	0	2
CLAMP_HIGH	Clamping High (50%)	0%	16
CLAMP_LOW	Clamping Low (50%)	100%	16
SMISM	Sensitivity mismatch factor X,Y	MLX	15
K	Sensitivity mismatch factor X (Y) , Z	MLX	15
Sel_K	Location for for K – correction	0	1
GAINMIN	Low threshold for virtual gain	00h	8
GAINMAX	High threshold for virtual gain	28h	8
GAINSATURATION	Gain Saturates on GAINMIX and GAINMAX	0h	1
PWMPOL	PWM polarity	1h	1
DP	Discontinuity point	0h	15
CW	Clock Wise	0h	1
MELEXISID1	Melexis identification reference	MLX	16
MELEXISID2	Melexis identification reference	MLX	16
MELEXISID3	Melexis identification reference	MLX	16
W	17pts – Output angle range	0h	4
LNR_Yn	17pts – Y-coordinate point n (n = 2,1,2 ...16)	0..100%	16
DIAG Settings	16 Bit Diagnostics enabling	FDFh	16
CRC_DISABLE	Enable EEPROM CRC check (3131h= disable)	0h	16
FILTER	FIR Filter	0	1
RAM Probe	Address for RAM probe	0	16
SERIAL_ID_1	Not available to USER until MemLock performed. See: <i>EEPROM_MLX90366_default_settings.doc</i> for more details	56EEh	16
SERIAL_ID_2	ID of user serial message #2	0	16
SERIAL_ID_3	ID of user serial message #3	0	16
SERIAL_ID_4	ID of user serial message #4	0	16
EE_SENT_SERIAL		0	16
EE_SERIAL_DATA_1		0	16
EE_SERIAL_DATA_2		0	16
EE_SERIAL_DATA_3		0	16
EE_SERIAL_DATA_4		0	16
EE_USERID1		1	16
EE_USERID2		303h	16
EE_USERID3		MLX	16

13. SENT output Protocol

13.1. Generality

The MLX90366 complies with the sub-set “A.3 Single Secure Sensors” of the norm J2716 Revised JAN2010, but one restriction: the mode without pause pulse is not featured.

13.2. Single Secure Fast Channel

MLX90366 delivers SENT frames according the Single Secure format. This format is explicitly described in this section.

13.2.1. Frame Content

The MLX90366 SENT frames have 6 data nibbles, and are formatted according the below table. The optional Pause Pulse is however always present so that every messages have the same fixed length.

SENT Frame :	Status	D1-MSN	D1-MidN	D1-LSN	D2-MSN	D2-MidN	D2-LSN	CRC	Optional Pause
--------------	--------	--------	---------	--------	--------	---------	--------	-----	----------------

Status[0]	Channel 1 indicator ("1" = error, "0" otherwise)
Status[1]	0
Status[2]	Enhanced Serial Message
Status[3]	Enhanced Serial Message
CRC	Enhanced CRC (the legacy CRC is not featured)
D1	12 bit angle
D2-MSN	D2-MSN=Rolling Counter-MSN
D2-MidN	D2-MidN=RollingCounter-MidN
D2-LSN	D2-LSN=Inverted copy of D1-MSN

13.2.2. Diagnostic Reporting through the fast channel

13.2.2.1. Diagnostic Reporting, bit Status[0]

The bit Status[0] is high whenever the three following conditions are met:

1. A diagnostic (analog/environmental) detects an error *
2. The reporting of the above error is enabled **
3. The debouncing time has elapsed.

* A diagnostic of type digital cause the circuit to switch in fail-safe-mode

** See EEPROM bits EE_DIAG_SETTINGS

13.2.2.2. Diagnostic Reporting, Channel 1

The diagnostic can be reported through the 12 bit payload of channel 1, and not only through the status bit Status[0].

The EEPROM parameters EE_ERRORCODE controls the diagnostic reporting through channel 1 as follow:

If $EE_REPORT[2:0]=0$, the channel 1 reports the angle, and not the diagnostic, as if no diagnostic.
The error is reported only thanks to the Status bits.

If $EE_REPORT[2:0]>0$, the channel1 payload contains the value $Channel1 = (4088 + EE_REPORT[2:0])$

13.2.2.3. Diagnostic Reporting Time

The Diagnostic **Reporting Time** is programmable (defined as multiple of a macro-cycle unit time).
A macro-cycle is a sequence of 20 angle acquisitions, and has a duration of approximately 6 ms.

13.2.2.4. Diagnostic Debouncing

The Diagnostic Reporting is **Debounced**. The debouncing parameter is user-programmable, by steps of approximately 6 ms.

13.2.3. Pause pulse

A pause pulse, as defined by the standard, is present at the end of every frame.
The pause pulse mode cannot be disabled.

The pause pulse length is adjusted by the circuit so that the frame period is constant.
The field sensing and the frame synchro pulse are in sync.

13.2.4. Fast Channel CRC

The MLX90366 features the new recommended implementation.

13.3. Slow Channel

13.3.1. Enhanced Serial Message

The circuit encodes the slow messages according the Enhanced Serial Message Format as specified at Chapter 5.2.4.3 of the SENT norm, except for the following restriction:

The configuration bit is always 0, meaning that the payload consists in 12-bit data and 8-bit message ID.

13.3.2. Serial Message Sequence

The circuit complies with the following sub-set specifications of the norm for pressure sensors (The norm for the angular sensor case does not specify the serial message format)

#	8bit ID	Item	12 bit data	Comments
1	29	Sensor ID	Prog.	EE_USERID1_12LSB
2	01	Error Code	RAM	Described at next chapter ...
3	2A	Sensor ID	Prog.	{EE_USERID2_8LSB, EE_USERID1_4MSB }
4	01 / 80	Error Code / User-defined RAM value	RAM	RAM variable @ address EE_RAM_PROBE_ADDR e.g. Temp, GainCode, FieldStrength
5	2B	Sensor ID	Prog.	{ EE_USERID3_4LSB,EE_USERID2_8MSB }
6	01	Error Code	RAM	
7	2C	Sensor ID	Prog.	EE_USERID3_12MSB
8	01 / 80	Error Code / User-defined RAM value	RAM	
Optional Part (EE_ExtendedSequence = 1)				
9	06	SENT Revision	003	
10	01	Error Code	RAM	
11	EE_SERIAL_ID1	User-defined #1	EE_SERIAL_DATA_1	e.g. Sensor type, Manufacturing code
12	01 / 80	Error Code / User-defined RAM value	RAM	RAM variable @ address EE_RAM_PROBE_ADDR e.g. Temp, GainCode, FieldStrength
13	EE_SERIAL_ID12	User-defined #2	EE_SERIAL_DATA_2	e.g. 07 – Transfer Characteristic
14	01	Error Code	RAM	
15	EE_SERIAL_ID3	User-defined #3	EE_SERIAL_DATA_3	e.g. 03 – Sensor Type
16	01 / 80	Error Code / User-defined RAM value	RAM	
17	EE_SERIAL_ID4	User-defined #4	EE_SERIAL_DATA_4	
18	01	Error Code	RAM	

Table. Serial Message Sequence

The first part (positions 1 to 8) provides the Error Code and the Sensor ID alternatively.

The second part (positions 9 to 18) is optional as a whole enabled with EEPROM bit EE_ExtendedSequence.

This second part consists of the error code (5 occurrences), 4 User-defined messages (ID and data) and the SENT revision.

13.3.3. Serial message sequence period

Sequence Length (serial message count)	Sequence Length (frame count)	Sequence Period (ms, typical)
8	144	121
18	324	273

13.3.3.1. User-defined RAM Value

The payloads of the positions 4, 8 (and 12, 16 if relevant) are user-defined. Three possibilities:

1. Error Code
2. 12 LSBs of a user-defined RAM value
3. 12 MSBs of a user-defined RAM value

The positions 4, 8, 12, 16 refer necessarily to the same user-defined RAM address. Three RAM addresses are of interest:

Variable name	Address	Description
ramTempSens	4E	Calibrated Temperature sensor value
VG	46	Actual Virtual Gain
Norm	48	Actual field norm

The actual absolute Temperature (T) can be derived from the 12 MSBs of ramTempSens (see possibility 3 above) using the following formula (decimal):

$$T = 8 \times (\text{ramTempSens} - 35) + 2048$$

The accuracy of the actual Temperature is = ± 10 DegC.

13.3.3.2. Error Code Rate

The Error Codes are on purpose transmitted every second message, to maximize the rate, which equals then 36 SENT frames, when the user-defined RAM mode is not enabled (72 otherwise).

13.3.4. Serial Message Error Code

Bit position	Diagnostic	Comments
0	GainOOS	Front-end Gain code Out-of-spec (too low, too high)
3	ADCSatura	Diag
4	ADCMonitor	ADC monitor
5	VanaMoni	Analog Internal Supply Too Low
6	VddMoni	External Supply Too Low, Too High
7	Rough Offset	Front-end Rough Offset too low, too high
8	TempMonitor	Temperature Sensor monitor

13.4. Start-up

During the chip initialization, the output remains high until the circuit emits four initialization frames (all 6 data nibble zero). The fifth frame is not an initialization frame but a valid frame containing a measured angle. See also section 8 “Timing specifications”.

13.5. Field sensing (ADC conversions) and the frame Synchro pulse

The digital angle (fast channel payload) results of the average of two angles. These angles are themselves computed from 4 ADCs values.

The time between the ADCs and the frame synchro pulse is constant.

As a result, the phase delay between the magnetic field angle and the SENT synchro pulse is constant, allowing filtering at the ECU side.

See also section 8 “Timing specifications”.

14. Description of End-User Programmable Items

14.1. Output Transfer Characteristic

To define the transfer function (LNR):

- With 17 equidistant points for which only the Y coordinates are defined.

Parameter	Value	Unit
CLOCKWISE	0 → CounterClockWise 1 → ClockWise	LSB
DP	0 ... 359.9999	Deg
LNR_Y0 LNR_Y1 ... LNR_Y16	-50 ... + 150	%
W	65.5 ... 360	Deg
CLAMP_LOW	0 ... 100	%
CLAMP_HIGH	0 ... 100	%

14.1.1. CLOCKWISE Parameter

The CLOCKWISE parameter defines the magnet rotation direction.

- CCW is defined by the 1-2-3-4 pin order direction for the Dual Mold Package.
- CW is defined by the reverse direction: 4-3-2-1 pin order direction for the Dual Mold Package

Refer to the drawing in the sensitive spot positioning section (Section 19.5)

14.1.2. Discontinuity Point (or Zero Degree Point)

The Discontinuity Point defines the 0° point on the circle. The discontinuity point places the origin at any location of the trigonometric circle. The DP is used as reference for all the angular measurements.

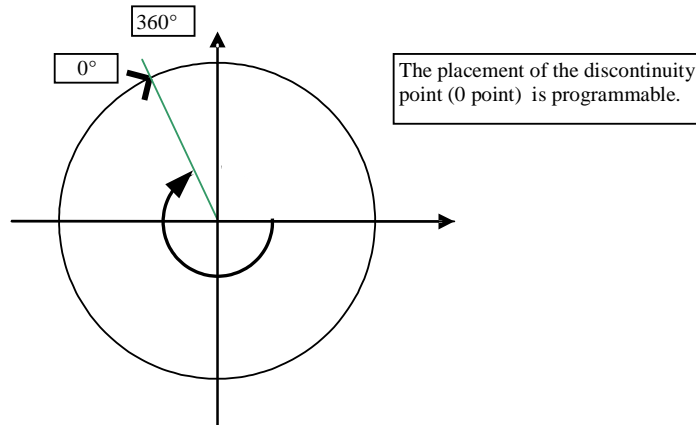

Figure 5 - Discontinuity Point Positioning

14.1.3. 17-Pts LNR Parameters

The LNR parameters, together with the clamping values, fully define the relation (the transfer function) between the digital angle and the output signal.

The shape of the MLX90366 transfer function from the digital angle value to the output voltage is described by the drawing below. In the 16-Pts mode, the output transfer characteristic is Piece-Wise-Linear (PWL).

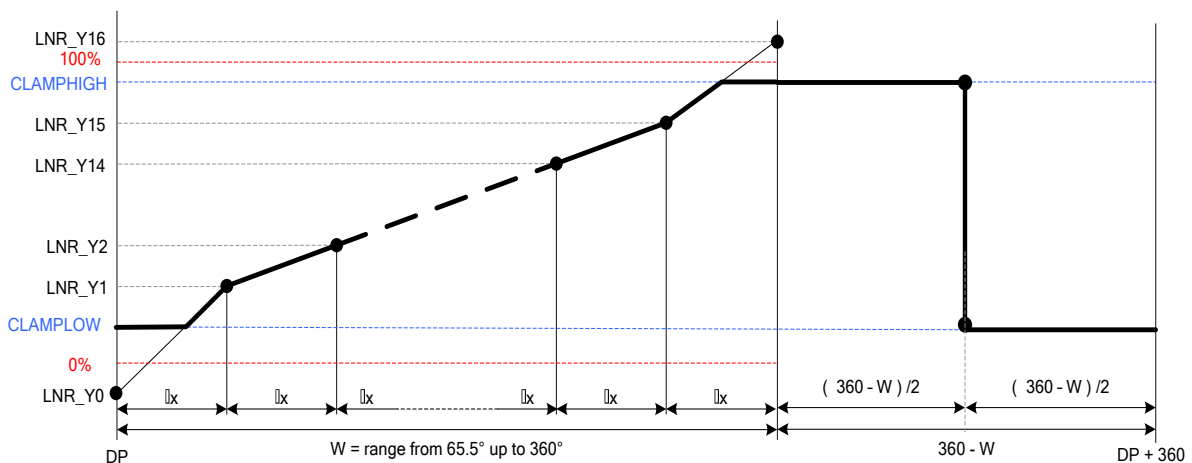

Figure 6 - Input range from 65.5° up to 360°

All the Y-coordinates can be programmed from -50% up to +150% to allow clamping in the middle of one segment (like on the figure), but the output value is limited to CLAMPLOW and CLAMPHIGH values.

Between two consecutive points, the output characteristic is interpolated.

The parameter W determines the input range on which the 17 points (16 segments) are uniformly spread:

W	Range	Δx
0 (0000b)	360.0deg	22.5deg
1	320.0deg	20.0deg
2	288.0deg	18.0deg
3	261.8deg	16.4deg
4	240.0deg	15.0deg
5	221.5deg	13.8deg
6	205.7deg	12.9deg
7	192.0deg	12.0deg

W	Range	Δx
8	180.0deg	11.3deg
9	144.0deg	9.0deg
10	120.0deg	7.5deg
11	102.9deg	6.4deg
12	90.0deg	5.6deg
13	80.0deg	5.0deg
14	72.0deg	4.5deg
15 (1111b)	65.5deg	4.1deg

Outside of the selected range, the output will remain in clamping levels.

14.1.4. CLAMPING Parameters

The clamping levels are two independent values to limit the output voltage range. The CLAMPLOW parameter adjusts the minimum output code. The CLAMPHIGH parameter sets the maximum output code. Both parameters have 16 bits of adjustment and are available for both LNR modes.

14.2. Identification

Parameter	Value
MELEXISID1	0 ... 65535
MELEXISID2	0 ... 65535
MELEXISID3	0 ... 65535
CUSTOMERID1	0 ... 65535
CUSTOMERID2	0 ... 65535
CUSTOMERID3	0 ... 65535

Identification number: 48 bits (3 words) freely useable by Customer for traceability purpose.

14.3. Sensor Front-End

Parameter	Value
MAPXYZ	0 .. 3
SMISM	0 .. 32768
K	0 .. 32768
SEL_k	0 or 1
GAINMIN	0 ... 41
GAINMAX	0 ... 41
GAINSATURATION	0.. 1

14.3.1. MAPXYZ

The MAPXYZ parameter defines which fields are used to calculate the angle. The different possibilities are described in the tables below.

This 2 bit value selects the first (B1) and second (B2) field components according the table below.

MAPXYZ	B1	B2	Angular
0 – 00b	X	Y	XY mode
1 – 01b	Zx	X	XZx mode
2 – 10b	Y	Zx	YZx mode
3 – 11b	Y	Zy	YZy mode

MAPXYZ = 3 is not recommended.

14.3.2. SMISM, k and SEL_k Parameters

(i) SMISM

When the mapping (B1=X, B2=Y) is selected, SMSIM defines the sensitivity mismatch factor that is applied on B1, B2; When another B1, B2 mapping is selected, this parameter is “don’t care”.

This parameter is trimmed at factory; Melexis strongly recommends TO NOT over write it for optimal performance.

(ii) k

When the mapping (B1=X, B2=Y) is **NOT** selected, k defines the sensitivity mismatch factor that is applied on B1 or B2 (according to parameter SEL_k – see below). When the mapping (B1=X, B2=Y) is selected, this parameter is “don’t care”.

This parameter is trimmed at factory for mapping (B1=Z, B2=X). Melexis recommends to fine trim it when a smaller linearity error (Le) is required and a different mapping than (B1=X, B2=Y) is selected.

(iii) SEL_k

When the mapping (B1=X, B2=Y) is **NOT** selected, SEL_k defines the component on which the sensitivity mismatch factor k (see above): SEL_k = 0 means $B1 \rightarrow k \cdot B1$ and SEL_k = 1 means $B2 \rightarrow k \cdot B2$.

14.3.3. GAINMIN and GAINMAX Parameters

GAINMIN and GAINMAX define the thresholds on the gain code outside which the fault “GAIN out of Spec.” is set;

If GAINSATURATION is set, then the virtual gain code is saturated at GAINMIN and GAINMAX, and no Diagnostic fault is set since the saturations apply before the Diagnostic check.

14.4. Filter

Parameter	Value
FILTER	0, 1

The MLX90366 features a filter that is enabled when FILTER = 1.

The filter is of type “moving average”. It averages the two most recent **internal** angle values. When the filter is enabled, the SENT data holds the average of the two most recent **internal** angles.

We recommend to enable the filter, in order to benefit from a noise reduction of 30% compared to the case FILTER = 0. Given that two angle values are computed per each SENT frame, the latency increases in this case only marginally.

Filter = 0 corresponds to no filtering, and may be selected to optimize the latency (by about 10%), whenever the latter is system-critical (e.g. stability of a close-loop system).

14.5. Diagnostic Features

Refer to Application_note_Diagnostic_Behavior_90366 for EE_CRC_Enable function description and for Diagnostic features which can be enabled at user.

14.6. EEPROM endurance

Although the EEPROM is used for Calibration Data Storage (similarly to an OTPROM), the MLX90366 embedded EEPROM is qualified to guarantee an endurance of minimum 1000 write cycles at 125°C for engineering/calibration purpose.

15. MLX90366 Self Diagnostic

The MLX90366 provides numerous self-diagnostic features. Those features increase potentially the functional safety of safety-related systems as it reduces the risk of erroneous angle reporting in case of internal or external failure modes (“fail-safe”).

Diagnostic Item	Action	Effect on Output	Type	Monitoring Rate	Reporting Rate
ST-up phase Diagnostics					
RAM March C- 10N Test	Fail-safe mode ** ** CPU reset after 120ms	Diagnostic low/ high Reporting (optional)	Digi HW	n/applicable (start-up only)	n/applicable (start-up only)
Watchdog BIST	Fail-safe mode ** ** CPU reset after 120ms	Diagnostic low/ high Reporting (optional)	Digi HW	n/applicable (start-up only)	n/applicable (start-up only)
Under Voltage Monitoring SUPPLYMONI = (MT3VB) OR (MT4VB)	St-up on Hold	Diagnostic low/high	Environ & Analog	n/applicable (start-up only)	n/applicable (start-up only)
Over Voltage Monitoring MT7V	PTC entry	OUT in HiZ	Environ	n/applicable (start-up only)	n/applicable (start-up only)
BG Loop Diag.					
ROM 16bit checksum (continuous)	Fail-safe mode ** ** CPU reset after 120ms	Diagnostic low//high Reporting (optional)	Digi HW	800ms	800ms
EEPROM 8 bit CRC Check (continuous)	Fail-safe mode ** ** CPU reset after 120ms	Diagnostic low/high Reporting (optional)	Digi HW	10ms	10ms
Watchdog (continuous)	CPU reset	--	Digi HW	120ms	n/a
DSP Loop Diag.					
ADC Clipping ADCCLIP	Debouncing (prog.)	SENT Status bit0 = 1 (optional)	Environ & Analog	5/DSP	6ms x INT (THRES/STEP_UP)
Virtual Gain Code Out-of-spec GAINOOS	Debouncing (prog.)	SENT Status bit0 = 1 (optional)	Environ & Analog	1/DSP	6ms x INT (THRES/STEP_UP)
Virtual Gain Code Saturation [GAINMIN..GAINMAX]	Saturation (optional)	Gain Saturated @ GAINMIN-GAINMAX	Environ & Analog	n/applicable Not a diagnostic	n/applicable Not a diagnostic
ADC Monitor (Analog to Digital Converter) ADCMONI	Debouncing (prog.)	SENT Status bit0 = 1 (optional)	Analog HW	1/DSP	6ms x INT (THRES/STEP_UP)
Under Voltage Monitoring SUPPLYMONI = (MT3VB) OR (MT4VB)	Supply Debouncing (prog.)	SENT Status bit0 = 1 (optional)	Environ & Analog	1/DSP	6ms x INT (THRES/STEP_UP)
Over Voltage Monitoring MT7V	PTC entry after PTC Debouncing	OUT in HiZ	Environ	2ms	2ms
Temperature Sensor Monitor TEMPMONI	Debouncing (prog.)	SENT Status bit0 = 1 (optional)	Analog	1/DSP	6ms x INT (THRES/STEP_UP)
Temperature > 170degC (± 20) Temperature < -60degC (± 20)	Saturate value used for the compensation to -40degC and +150degC resp.	No effect	Environ & Analog		n/applicable Not a diagnostic
Hardware Diag. (continuously checked by dedicated Logic)					
Read/Write Access out of physical memory	Fail-safe mode ** ** CPU reset after 120ms	Diagnostic Low/High	Digi HW	n/a immediate Diag	n/a immediate Diag
Write Access to protected area (IO and RAM Words)	Fail-safe mode ** ** CPU reset after 120ms	Diagnostic low/high	Digi HW	n/a immediate Diag.	n/a immediate Diag.
Unauthorized Mode Entry	Fail-safe mode ** ** CPU reset after 120ms	Diagnostic low/high	Digi HW	n/a immediate Diag	n/a immediate Diag
EEPROM Error Correcting Code (Hamming correction)	(Transparent) Error Correction	no effect	Digi HW	n/a.	n/a
Hardware Diag. (continuously checked by dedicated Analog circuits)					
Broken VSS	CPU Reset on recovery	Pull down load => Diag. Low Pull up load => Diag. High	Environ	n/a immediate Diag.	n/a immediate Diag.
Broken VDD	CPU Reset on recovery	Pull down load => Diag. Low Pull up load => Diag. High	Environ	n/a immediate Diag	n/a immediate Diag
Resistive Cable Test	St-up on Hold	Diagnostic low/high	Environ	n/a immediate Diag.	n/a immediate Diag.

16. Built-in Capacitors

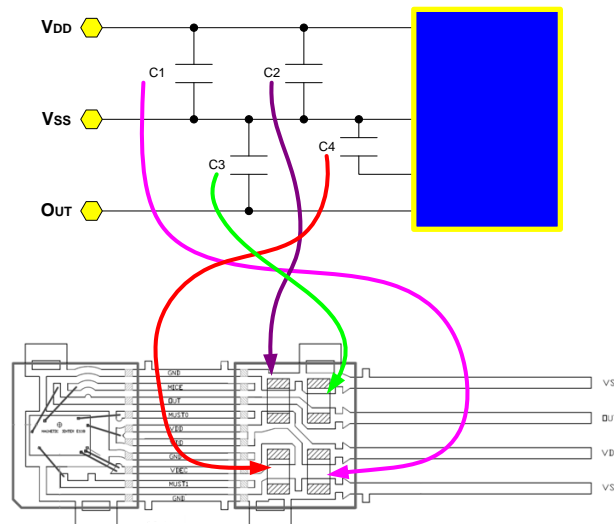

Either Vss pin can be used for grounding, but always leave 1 floating.
 Built-in capacitors are ceramic multilayer type X8R. The capacitors are specifically suited for high temperature applications with stable capacitance value ($\pm 15\%$) up to 150 DegC.
 The capacitors are assembled using a gluing method instead of soldering to be more reliable towards thermal/mechanical stress. The maximum rated voltage is 25V. C1=C2=C4 = 100nF and C3 = 10nF.

17. Standard information regarding manufacturability of Melexis products with different lead pre-forming and soldering/welding processes

For Dual Mold Package, please refer to the following document (available upon request):
[Application Note Hall Sensors in Dual Mold Packages – \(Doc#: 390110000001\)](#)

For more information on the lead free topic please see quality page at our website:
<http://www.melexis.com/quality.aspx>

18. ESD Precautions

Electronic semiconductor products are sensitive to Electro Static Discharge (ESD).
 Always observe Electro Static Discharge control procedures whenever handling semiconductor products.

19. Package Information

19.1. DMP-4 – Package Outline Dimensions (POD) – Straight Leads

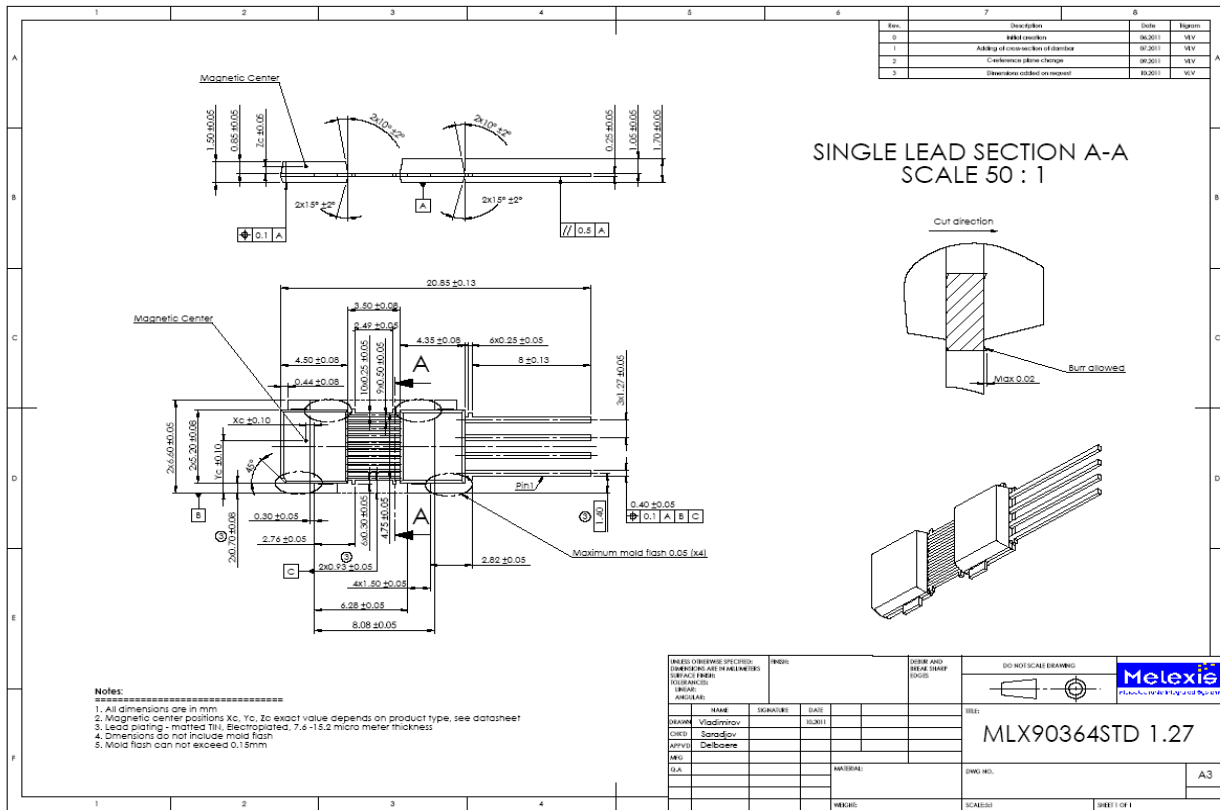

MLX90366LVS-xxx-200

19.2. DMP-4 – Package Outline Dimensions (POD) – Trimmed & Formed Leads [1]

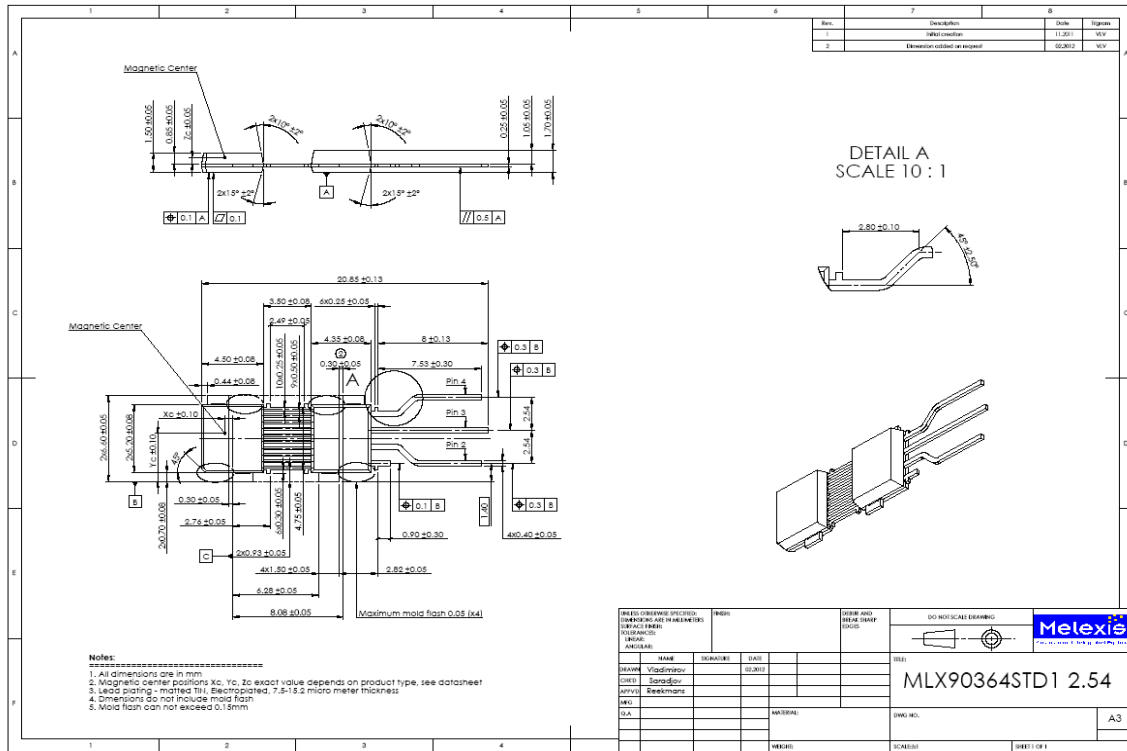

MLX90366LVS-xxx-201

19.3. DMP-4 – Package Outline Dimensions (POD) – Trimmed & Formed Leads [2]

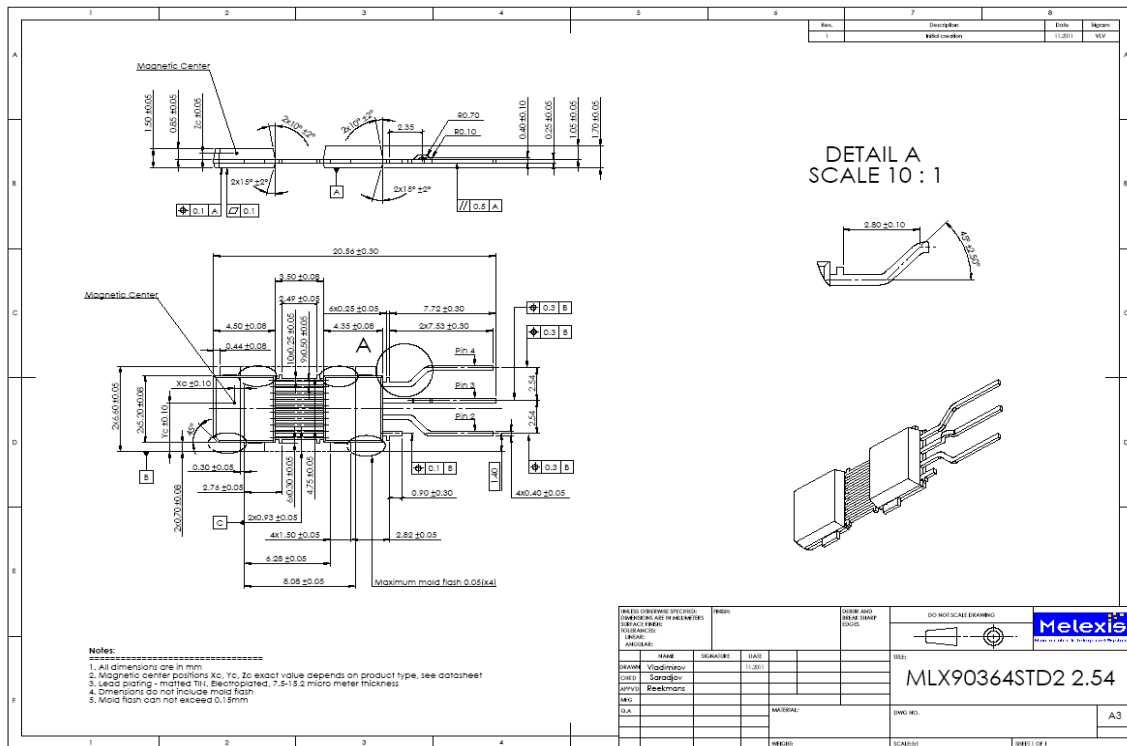

MLX90366LVS-xxx-203

19.4. DMP-4 - Marking

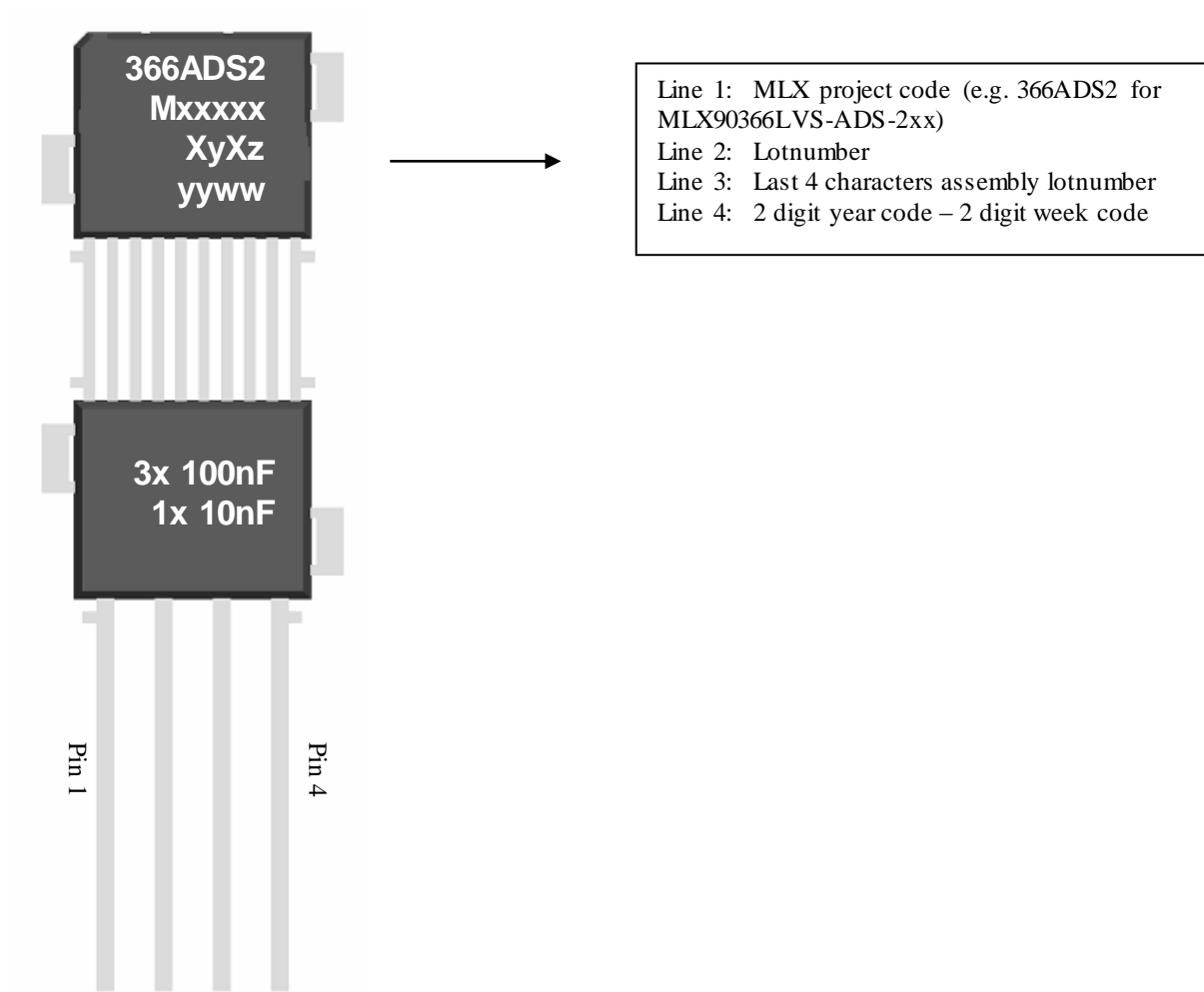

19.5. DMP-4 - Sensitive Spot Positioning & Sense direction

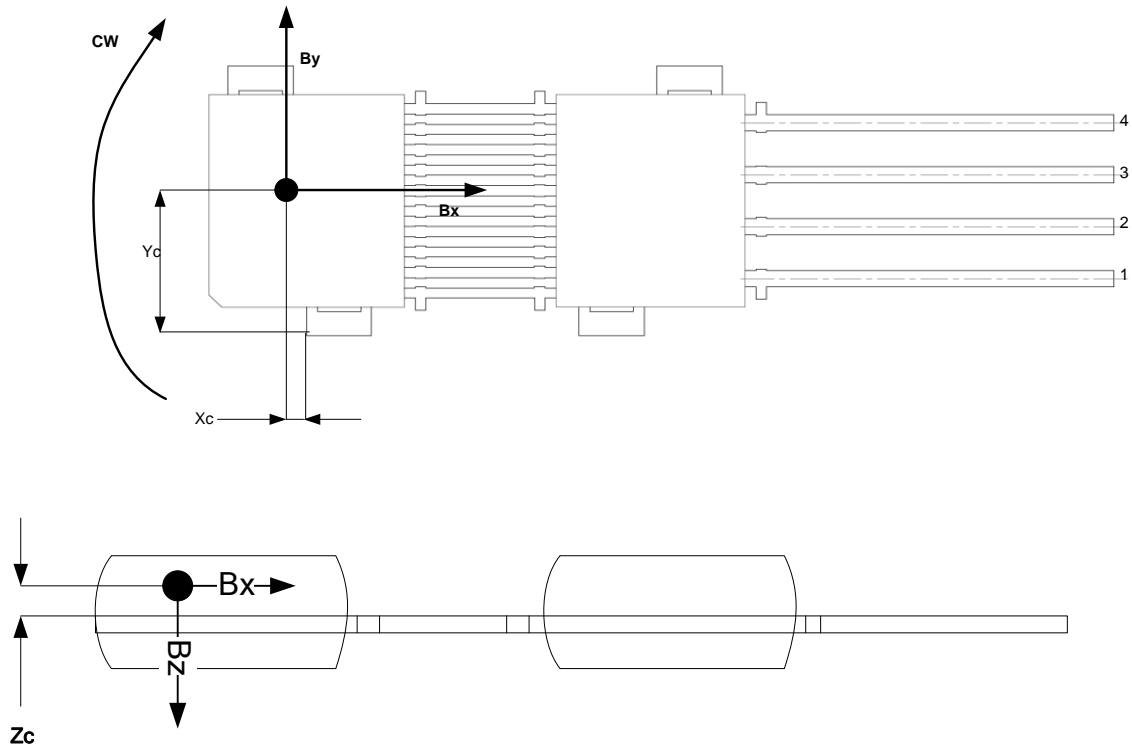

Magnetic center position	MLX90366LVS-xxx-2xx
Xc	0.23
Yc	3.67
Zc	0.495

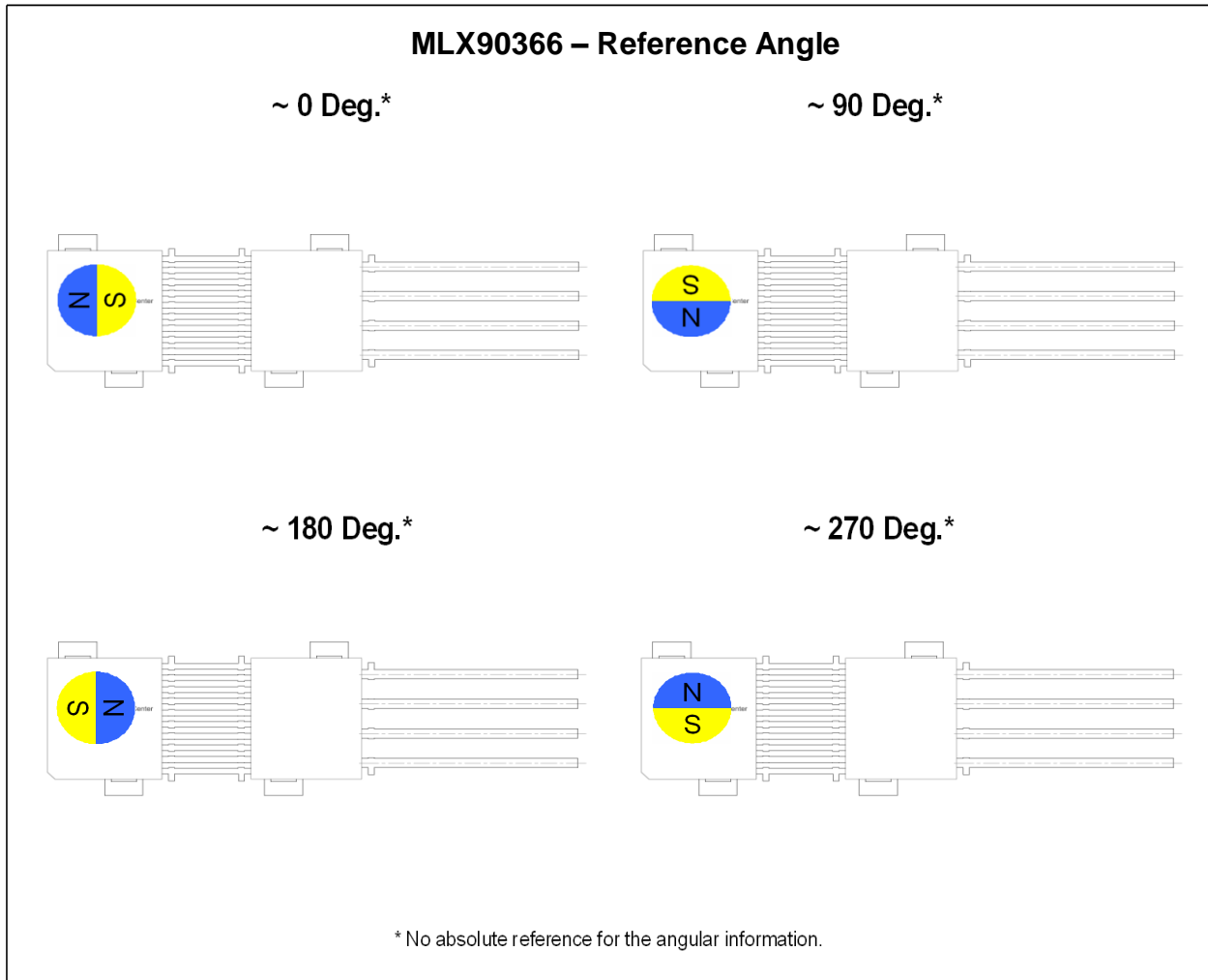

The MLX90366 is an absolute angular position sensor but the linearity error (See section 9) does not include the error linked to the absolute reference 0 Deg (which can be fixed in the application through the discontinuity point).

20. Disclaimer

Devices sold by Melexis are covered by the warranty and patent indemnification provisions appearing in its Term of Sale. Melexis makes no warranty, express, statutory, implied, or by description regarding the information set forth herein or regarding the freedom of the described devices from patent infringement. Melexis reserves the right to change specifications and prices at any time and without notice. Therefore, prior to designing this product into a system, it is necessary to check with Melexis for current information. This product is intended for use in normal commercial applications. Applications requiring extended temperature range, unusual environmental requirements, or high reliability applications, such as military, medical life-support or life-sustaining equipment are specifically not recommended without additional processing by Melexis for each application.

The information furnished by Melexis is believed to be correct and accurate. However, Melexis shall not be liable to recipient or any third party for any damages, including but not limited to personal injury, property damage, loss of profits, loss of use, interrupt of business or indirect, special incidental or consequential damages, of any kind, in connection with or arising out of the furnishing, performance or use of the technical data herein. No obligation or liability to recipient or any third party shall arise or flow out of Melexis' rendering of technical or other services.

© 2013 Melexis N.V. All rights reserved.

For the latest version of this document, go to our website at
www.melexis.com

Or for additional information contact Melexis Direct:

Europe, Africa, Asia:

Phone: +32 1367 0495

E-mail: sales_europe@melexis.com

America:

Phone: +1 248 306 5400

E-mail: sales_usa@melexis.com

ISO/TS 16949 and ISO14001 Certified