

## Revision History

### Revision 1 ( Dec. 2001 )

- 1.Fister release.

### Revision 2 ( Apr. 2002 )

1. Changed module current specification.
2. Add Performance range.
3. Changed AC Characteristics.
4. Changed typo size on module PCB in package dimensions.

## General Description

The ADD8608A8A are four-bank Double Data Rate(DDR) Synchronous DRAMs organized as 8,392,608 words x 8 bits x 4 banks, Synchronous design allows precise cycle control with the use of system clock I/O transactions are possible on every clock cycle. Data outputs occur at both rising edges of CK and /CK.

Range of operating frequencies, programmable burst length and programmable latencies allow the same device to be useful for a variety of high bandwidth high performance memory system applications

## Features

- 2.5V for VDDQ power supply
- SSTL\_2 interface
- MRS Cycle with address key programs
  - CAS Latency (2, 2.5)
  - Burst Length (2,4 &8)
  - Burst Type (sequential & Interleave)
- 4 banks operation
- Differential clock input (CK, /CK) operation
- Double data rate interface
- Auto & Self refresh
- 8192 refresh cycle
- DQM for masking
- Package:66-pins 400 mil TSOP-Type II

## Ordering Information.

Part No.	Frequency	Interface	Package
ADD8608A8A-75BA	133Mhz(7.5ns/CL=2)	SSTL_2	400mil 66pin TSOPII
ADD8608A8A-75B	133Mhz(7.5ns/CL=2.5)		

## Pin Assignment

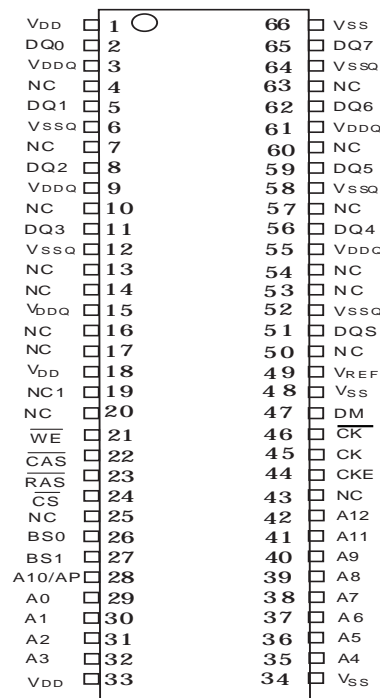

66-pin plastic TSOP II 400 mil

### Pin Description

PIN	NAME	FUNCTION
CK, /CK	System Clock	Differential clock input.
CKE	Clock Enable	Masks system clock to freeze operation from the next clock cycle. CKE should be enabled at least on cycle prior new command. Disable input buffers for power down in standby
/CS	Chip Select	Disables or Enables device operation by masking or enabling all input except CK, CKE and DQ
A0~A12	Address	Row / Column address are multiplexed on the same pins. Row address : A0~A12 Column address : A0~A9
BS0~BS1	Banks Select	Selects bank to be activated during row address latch time. Selects bank for read / write during column address latch time.
DQ0~DQ7	Data	Data inputs / outputs are multiplexed on the same pins.
/RAS	Row Address Strobe	Latches row addresses on the positive edge of the CLK with /RAS low
/CAS	Column Address Strobe	Latches Column addresses on the positive edge of the CLK with /CAS low
/WE	Write Enable	Enables write operation and row recharge.
VDD/VSS	Power Supply/Ground	Power and Ground for the input buffers and the core logic.
VDDQ/VSSQ	Data Output Power/Ground	Power supply for output buffers.
VREF	Reference Voltage	Reference voltage for inputs for SSTL interface.
NC	No Connection	This pin is recommended to be left No Connection on the device.

### Block Diagram

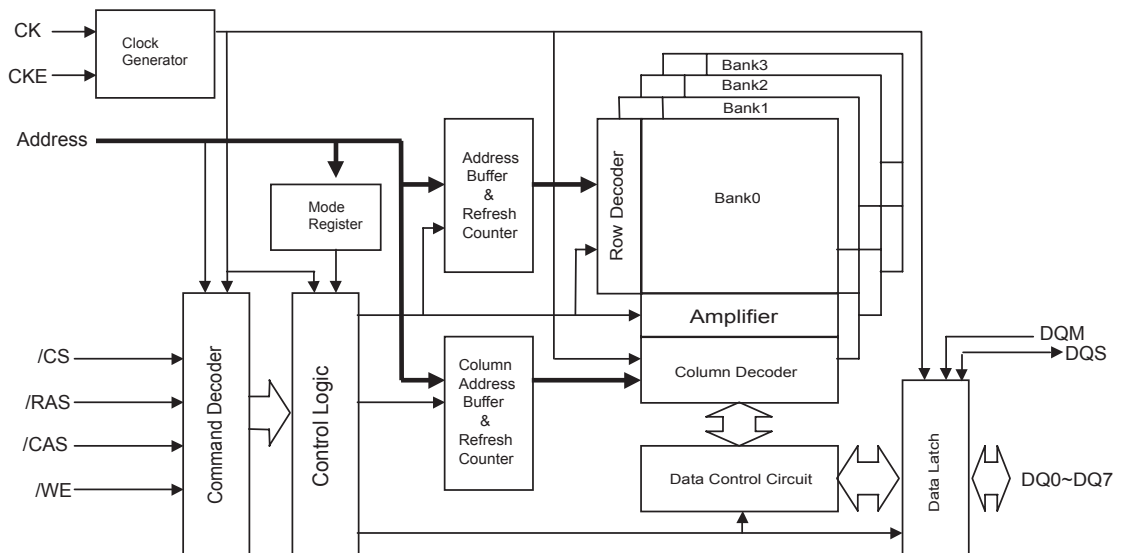

## Absolute Maximum Ratings

Parameter	Symbol	Value	Unit
Voltage on any pin relative to Vss	V <sub>IN</sub> , V <sub>out</sub>	-0.5 ~ 3.6	V
Voltage on VDD supply relative to Vss	V <sub>DD</sub> , V <sub>DDQ</sub>	-1.0 ~ 3.6	V
Storage temperature	T <sub>STG</sub>	-55 ~ +150	°C
Power dissipation	P <sub>D</sub>	1.5	W
Short circuit current	I <sub>OUT</sub>	50	mA

**Note** : Permanent device damage may occur if ABSOLUTE MAXIMUM RATING are exceeded.

Functional operation should be restricted to recommended operating condition.

Exposure to higher than recommended voltage for extended periods of time could affect device reliability.

## DC Operating Condition

Voltage referenced to Vss = 0V, T<sub>A</sub> = 0 to 70 °C

Parameter	Symbol	Min	Max	Unit	Note
Supply voltage	V <sub>DD</sub>	2.3	2.7	V	
Supply voltage	V <sub>DDQ</sub>	2.3	2.7		1
Input logic high voltage	V <sub>IH</sub>	V <sub>REF</sub> +0.15	V <sub>DDQ</sub> +0.3	V	
Input logic low voltage	V <sub>IL</sub>	-0.3	V <sub>REF</sub> -0.15	V	2
Differential Clock DC Input voltage	V <sub>ICK</sub>	-0.3	V <sub>DDQ</sub> +0.3	V	
Input Differential CLK&/CLK voltage	V <sub>ID</sub>	0.7	V <sub>DDQ</sub> +0.6-	V	
Input leakage current	I <sub>IL</sub>	-5	5	uA	3
Output leakage current	I <sub>OL</sub>	-5	5	uA	4
Reference Voltage	V <sub>REF</sub>	0.49* V <sub>DDQ</sub>	0.51* V <sub>DDQ</sub>	V	
Termination Voltage	V <sub>TT</sub>	V <sub>REF</sub> -0.04	V <sub>REF</sub> +0.04		5

**Note** : 1. V<sub>DDQ</sub> must not exceed the level of V<sub>DDQ</sub>.

2. V<sub>IL</sub>(min)=-0.9V with a pulse width ≤ 5ns .

3. Any input 0V ≤ V<sub>IN</sub> ≤ 3.6V, all other pins are not under test = 0V.

4. Dout is disabled, 0V ≤ V<sub>OUT</sub> ≤ 2.7V.

5. V<sub>REF</sub> is expected to be equal to 0.5\* V<sub>DDQ</sub> of the transmitting device, and to track variations in the DC level of the same. Peak to peak noise on V<sub>REF</sub> may not exceed ±2% of the DC value.

## AC Operating Condition

Voltage referenced to  $V_{SS} = 0V$ ,  $T_A = 0$  to  $70^\circ C$

Parameter	Symbol	Value	Unit	Note
AC input high / low level voltage	$V_{IH} / V_{IL}$	$V_{REF}+0.31/V_{REF}-0.31$	V	
Input timing measurement reference level voltage	$V_{trip}$	1.4	V	
Input rise / fall time	$T_R / t_F$	1	Ns	
Output timing measurement reference level	$V_{outf}$	1.4	V	
Output load capacitance for access time measurement	CL	50	pF	2

**Note:** 1.  $3.15V \leq V_{DD} \leq 3.6V$  is applied for VDD8608A4A5.

2. Output load to measure access times is equivalent to two TTL gates and one capacitor (30pF). For details, refer to AC/DC output load circuit.

## Capacitance

$T_A=25^\circ C$ ,  $f=1Mhz$

Parameter	Pin	Symbol	Min	Max	Unit
Input capacitance	CK, /CK	CI1	2	3.0	pF
	A0~A12,BS0,BS1,CKE,/CS,/RAS, /CAS,/WE,DQM	CI2	2	3.0	pF
Data input / output capacitance	DQM	CI/O	4	5	pF

## Output load circuit

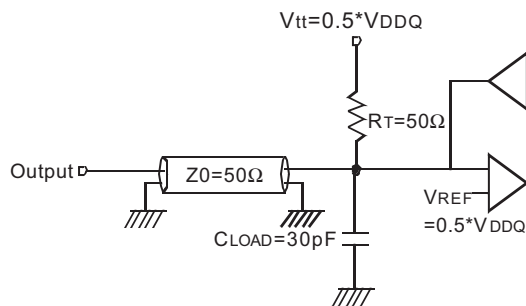

**Output Load Circuit (SSTL\_2)**

## DC Characteristics II

Parameter	Symbol	Test condition	Speed	Unit	Note
			-75BA/-75B		
Operating Current	IDD1	Burst length=2, One bank active Trc=tRC(min), I <sub>OUT</sub> =0mA	110	mA	1
Precharge standby current in power down mode	IDD2P	CKE ≤ V <sub>IL</sub> (max), tCK=min	3	mA	
Precharge standby current in Non power down mode	IDD2N	CKE ≥ V <sub>IH</sub> (min), /CS ≥ V <sub>IH</sub> (min), tCK= tCK min input signals are changed one time during 2clks.	40	mA	
Active standby current in power down mode	IDD3P	CKE ≤ V <sub>IL</sub> (max), tCK= tCK min	30	mA	
Active standby current in Non power down mode	IDD3N	CKE ≥ V <sub>IH</sub> (min), /CS ≥ V <sub>IH</sub> (min), tCK=min input signals are changed one time during 2clks.	65	mA	
Burst mode operating current	IDD4R	tCK ≥ tCK(min), I <sub>OUT</sub> =0 mA All banks active	155	mA	1
Auto refresh current	IDD5	tRRC ≥ tRRC(min), All banks active	190	mA	2
Self refresh current	IDD6	CKE ≤ 0.2V	3	mA	

**Note:** 1. IDD1 and IDD4 depend on output loading and cycle rates. Specified values are measured with the output open.

2. Min. of tRRC is shown at AC characteristics.

## AC Characteristics

Parameter		Symbol	-75BA		-75B		Unit
			Min	Max	Min	Max	
System clock Cycle time	/CAS Latency = 2.5	tCK2.5	7.5	12	7.5	12	ns
	/CAS Latency = 2	tCK2	7.5	12	10	12	
Clock high pulse width		tCHW	0.45	0.55	0.45	0.55	CLK
Clock low pulse width		tCLW	0.45	0.55	0.45	0.55	CLK
Access time form CK to /CK		tAC	-0.75	0.75	-0.75	0.75	ns
Data strobe edge to clock edge		tDQSCK	-0.75	0.75	-0.75	0.75	ns
Clock to first rising edge of DQS delay		tDQSS	0.75	1.25	0.75	1.25	CLK
/RAS cycle time		tRC	65	-	65	-	ns
/RAS to /CAS delay		tRCD	20	-	20	-	ns
/RAS active time		tRAS	45	120K	45	120K	ns
/RAS precharge time		tRP	20	-	20	-	ns
/RAS to /RAS bank active delay		tRRD	15	-	15	-	ns
/CAS to /CAS delay		tCCD	1	-	1	-	CLK
Data-in setup time (to DQS)		tDS	0.5	-	0.5	-	ns
Data-in hold time (to DQS)		tDH	0.5	-	0.5	-	ns
DQS Falling Edge to CLK Setup Time		tDSS	0.2	-	0.2	-	CLK
DQS Falling Edge Hold Time from CLK		tDSH	0.2	-	0.2	-	CLK
Input setup time		tIS	0.9	-	0.9	-	ns
Input hold time		tIH	0.9	-	0.9	-	ns
DQS-in high level width		tDSH	0.35	-	0.35	-	CLK
DQS-in low level width		tDSL	0.35	-	0.35	-	CLK
Clock to DQS write preamble setup time		tWPRES	0	-	0	-	ns
Write preamble		tWPST	0.4	06	0.4	06	CLK
Data strobe edge to output data edge		tDQSQ		0.5		0.5	ns
Mode register set cycle time		tMRD	15		15		
DQS read preamble		tRPRE	0.9	1.1	0.9	1.1	CLK

## Command Truth-Table

Command	CKEn-1	CKEn	/CS	/RAS	/CAS	/WE	DM	ADDR	A10/AP	BS
Mode Register Set	H	X	L	L	L	L	X	CA	CA	L
No Operation	H	X	L	H	H	H	X	X		
Bank Active	H	X	L	L	H	H	X	V		V
Read	H	X	L	H	L	H	X	V	L	V
Read with Auto Precharge									H	
Write	H	X	L	H	L	L	X	V	L	V
Write with Auto Precharge									H	
Precharge All Bank	H	X	L	L	H	L	X	X	H	X
Burst Stop	H	X	L	H	H	L	X	X		
Auto Refresh	H	H	L	L	L	H	X	X		
Self Refresh	Entry	H	L	L	L	L	H	X	X	
	Exit	L	H	H	X	X	X	X		
Precharge	Entry	H	L	H	X	X	X	X	X	
				L	H	H	H			
Power down	Exit	L	H	H	X	X	X	X		
				L	H	H	X			
Data write	Enable	H	X	X	X	X	X	L	X	
	Disable	H	X	X	X	X	X	H		



## Package Information

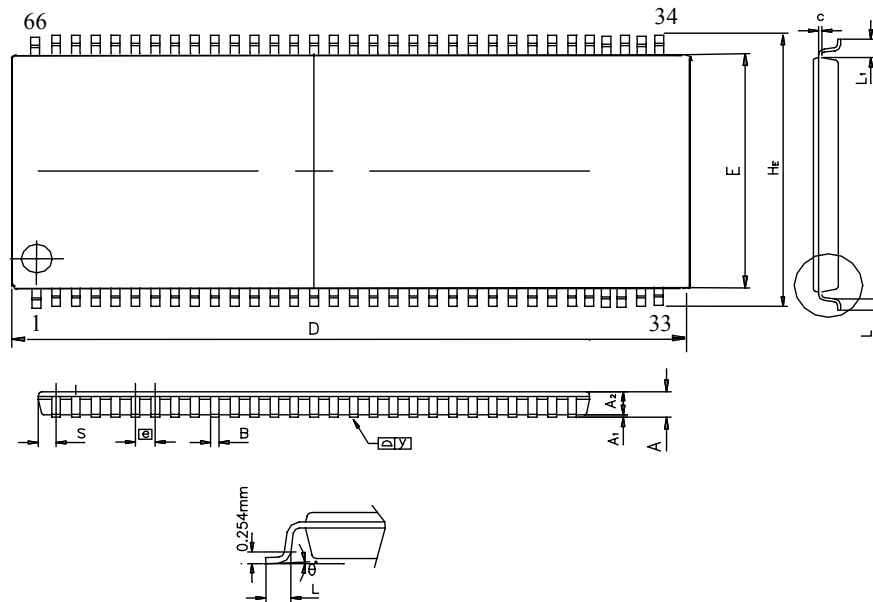

SYMBOL	MILLIMETER			INCH		
	MIN.	NOM.	MAX.	MIN.	NOM.	MAX.
A			1.20			0.047
A1	0.05		0.15	0.002		0.006
A2	0.95	1.00	1.05	0.037	0.039	0.041
B	0.17	0.24	0.32	0.007	0.009	0.013
c	0.09	0.145	0.2	0.004	0.0006	0.008
D	22.62 BSC			0.891 BSC		
H <sub>E</sub>	11.74	11.76	11.78	0.462	0.463	0.464
E	10.15	10.16	10.17	0.3996	0.400	0.4004
e	0.65 BSC			0.026		
L	0.40	0.50	0.60	0.016	0.020	0.024
L1	0.80 REF			0.031 REF		
S	0.71 REF			0.028 REF		
θ	0°	-	8°	0°	-	8°

400mil 66pin TSOP II Package