

181-040 M29504/15 Type Front Release Socket Terminus Size 16

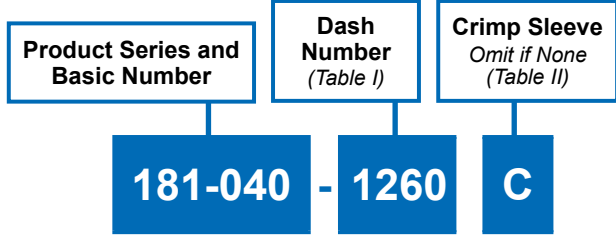

TABLE II: CRIMP SLEEVE DESIGNATOR		
Designator	Cable Diameter	Part Number
C	2.0-2.4 mm (MIL-Spec)	265-008

C

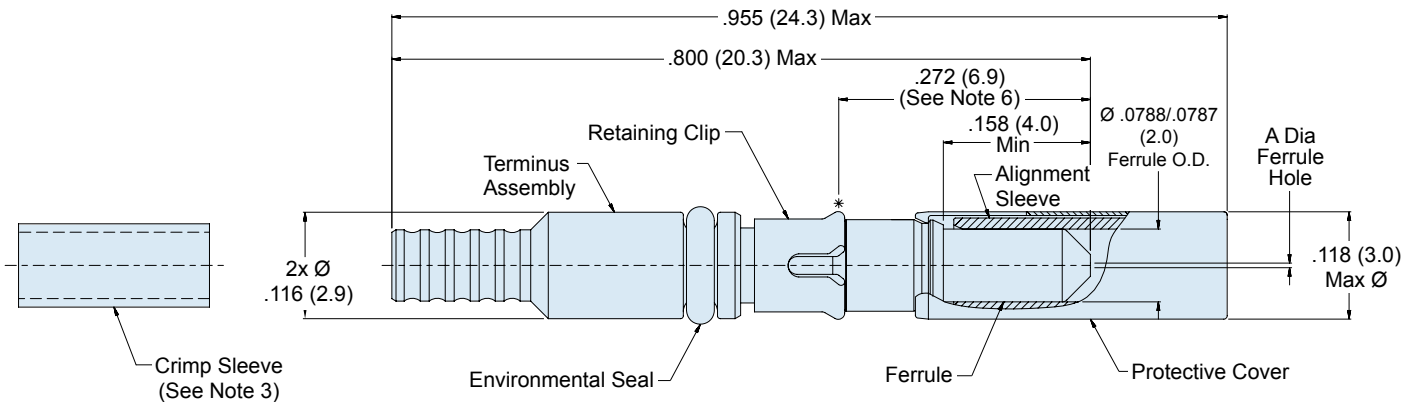

TABLE I: DASH NUMBER			
Assembly Dash Number	A Dia (Microns)	Typical Fiber Type	MIL-SPEC Type
-1255	125.5	Single Mode	N/A
-1260	126.0	Single Mode	N/A
		Multi Mode	M29504/15-4171
-1270	127.0	Multi Mode	M29504/15-4172
-1420	142.0	Multi Mode	M29504/15-4175

Consult Factory for Additional Sizes

TABLE III: TERMINUS ACCESSORIES	
Part Number	Accessory
265-010	Alignment Sleeve Assembly
182-012	Crimp Tool
182-013	Insertion Tool, Straight
182-014	Insertion Tool, 90°
182-015	Removal Tool
182-016	Alignment Sleeve Assembly Insertion/Removal Tool
182-035	Hand Polishing Tool

APPLICATION NOTES

- | | |
|--|--|
| <ol style="list-style-type: none"> 1. Assembly packaged in plastic bag and tag identified with manufacturer's name and part number 2. Material/ Finish:
Alignment Sleeve, Ferrule: Zirconia Ceramic/ N.A.
Protective cover: Spring Alloy / Nickel
Terminus Assembly: Stainless Steel / Passivate
Retaining Clip: Spring Alloy / N.A.
Seal: Fluorosilicone
Crimp Sleeve: Brass Alloy / Nickel | <ol style="list-style-type: none"> 3. Alignment Sleeve Assembly and Crimp Sleeve may be ordered separately (Tables II and III) 4. Metric dimensions (mm) are in parentheses. 5. Dummy Terminus: Part Number 181-051 6. Dimension to be measured when installed into insert equivalent fixture per MIL-PRF-29504/15 7. For use with MIL-PRF-28876 type connectors. |
|--|--|

Mouser Electronics

Authorized Distributor

Click to View Pricing, Inventory, Delivery & Lifecycle Information:

[Glenair:](#)

[181-040-1260](#) [181-040-1260C](#)