

RECOMMENDED HOLE LAYOUT FOR .070/(1.78)MAX. THICK P.C. BOARD

(SCALE: 2X)

CIRCUIT SIZE	DIM. "A"	DIM. "B"	DIM. "C"	DIM. "D"	DIM. "E"
4	.17 (4.2)	.38 (9.6)	.535 (13.60)	.590 (15.00)	.685 (17.40)
6	.33 (8.4)	.54 (13.8)	.701 (17.80)	.756 (19.20)	.850 (21.60)
10	.66 (16.8)	.87 (22.2)	1.031 (26.20)	1.087 (27.60)	1.181 (30.00)
12	.83 (21.0)	1.04 (26.4)	1.187 (30.40)	1.252 (31.80)	1.346 (34.20)
14	.99 (25.2)	1.20 (30.6)	1.362 (34.60)	1.417 (36.00)	1.512 (38.40)
16	1.16 (29.4)	1.37 (34.8)	1.528 (38.80)	1.583 (40.20)	1.677 (42.60)
18	1.32 (33.6)	1.54 (39.0)	1.693 (43.00)	1.748 (44.40)	1.843 (46.80)
24	1.82 (46.2)	2.03 (51.6)	2.189 (55.60)	2.244 (57.00)	2.339 (59.40)

LEGEND

46011 - * * 0 *

BASE NUMBER

CIRCUIT SIZE

HOUSING MATERIAL & PLATING

- 0 = V-2 / TIN
- 1 = V-2 / GOLD
- 2 = V-0 / TIN
- 3 = V-0 / GOLD

NOTES:

- 1) HOUSING MATERIAL & PLATING:
 0 = NYLON 6/6, UNFILLED UL 94V-2, COLOR: NATURAL, MATTE TIN PLATING
 1 = NYLON 6/6, UNFILLED UL 94V-2, COLOR: NATURAL, SELECT GOLD PLATING
 2 = NYLON 6/6, UNFILLED UL 94V-0, COLOR: NATURAL, MATTE TIN PLATING
 3 = NYLON 6/6, UNFILLED UL 94V-0, COLOR: NATURAL, SELECT GOLD PLATING
 TERMINAL MATERIAL : COPPER ALLOY
- 2) TERMINAL PLATING:
 ("TIN") .000100/(.00254) MIN. MATTE TIN OVER
 .000050/(.00127) MIN. NICKEL OVERALL.
 ("GOLD") .000030/(.00076) MIN. SELECT GOLD & .000100/(.00254) MIN. MATTE TIN OVER .000050/(.00127) MIN. NICKEL OVERALL.
- 3) PRODUCT SPECIFICATION: PS-45750-001
- 4) PACKAGING SPECIFICATION: PK-42440-001.
- 5) 6-24 CKT. PARTS MATE WITH MINI-FIT JR. RECEPTACLE 5557, VERTICAL RECEPTACLE HEADER 46010 & BMI RECEPTACLES 42474, AND 44516. 4 CKT PART MATES WITH 42474,44516 AND 46010 ONLY.
- 6) RIB LOCATION IS DETERMINED BY MOLD DESIGN FOR MANUFACTURING EASE AND THE LOCATION DOES NOT AFFECT PART FUNCTION OR PERFORMANCE. LOCATION OF RIBS MAY VARY ON PARTS WITHIN MANUFACTURING LOT OR SHIPMENT. THIS DRAWING SHOWS TYPICAL RIB LOCATIONS.
- 7) CONNECTOR ASSEMBLIES ARE NOT TO BE MATED OR UNMATED WHILE CIRCUITS ARE LIVE.
- 8) PART ALLOWS FOR UP .100/(2.54) MISALIGNMENT WITH MATING RECEPTACLE IN ANY DIRECTION. SEE MATING CONNECTOR DRAWINGS FOR SPECIFIC ALLOWANCES.
- 9) THIS PART CONFORMS TO CLASS B REQUIREMENTS OF COSMETIC SPECIFICATION PS-45499-002.
- 10) CONNECTOR IS NOT DESIGNED FOR CURRENT SHARING.
- 11) 12 CIRCUIT PARTS HAVE A SLOT BETWEEN CIRCUITS 7 AND 8.

QUALITY SYMBOLS	THIS DRAWING CONTAINS INFORMATION THAT IS PROPRIETARY TO MOLEX INCORPORATED AND SHOULD NOT BE USED WITHOUT WRITTEN PERMISSION		DIMENSION UNITS	SCALE	molex	
▽ = 0	ADD 46011-5001 2015/09/07 EC NO: 101245 DRWN: NKN02 CHKD: APPR:	GENERAL TOLERANCES (UNLESS SPECIFIED)	IN/MM	4:1		MINI-FIT VERTICAL BMI HEADER ASSEMBLY (HCS PLUS SERIES)
▽ = 0		ANGULAR TOL ± 1/2 °	DRWN BY	DATE		
▽ = 0		4 PLACES ± ---	TGREGORI	2006/05/19		
▽ = 0		3 PLACES ± ---	CHK'D BY	DATE		
▽ = 0	2 PLACES ± 0.25	JCOMERCI			PRODUCT CUSTOMER DRAWING	
▽ = 0	1 PLACE ± 0.38	APPR BY	DATE			
□ = 0	0 PLACES ±	JCOMERCI				
■ = 0		DRAFT WHERE APPLICABLE MUST REMAIN WITHIN DIMENSIONS	DRAWING SIZE	THIRD ANGLE PROJECTION		
▽ = 0	B2		C		SERIES	
					46011	
					MATERIAL NUMBER	
					SEE SHEET 2	
					CUSTOMER	
					GENERAL MARKET	
					DOCUMENT NUMBER	
					SD-46011-001	
					DOC TYPE	
					PSD	
					DOC PART	
					000	
					SHEET NUMBER	
					1 OF 2	

PART NUMBER	CIRCUIT SIZE	U.L. RATING	PLATING
46011-0400	4	V-2	TIN
46011-0401	4	V-2	GOLD
46011-0402	4	V-0	TIN
46011-0403	4	V-0	GOLD
46011-0600	6	V-2	TIN
46011-0601	6	V-2	GOLD
46011-0602	6	V-0	TIN
46011-0603	6	V-0	GOLD
46011-1000	10	V-2	TIN
46011-1001	10	V-2	GOLD
46011-1002	10	V-0	TIN
46011-1003	10	V-0	GOLD
46011-1200	12	V-2	TIN
46011-1201	12	V-2	GOLD
46011-1202	12	V-0	TIN
46011-1203	12	V-0	GOLD
46011-1400	14	V-2	TIN
46011-1401	14	V-2	GOLD
46011-1402	14	V-0	TIN
46011-1403	14	V-0	GOLD
46011-1600	16	V-2	TIN
46011-1601	16	V-2	GOLD
46011-1602	16	V-0	TIN
46011-1603	16	V-0	GOLD
46011-1800	18	V-2	TIN
46011-1801	18	V-2	GOLD
46011-1802	18	V-0	TIN
46011-1803	18	V-0	GOLD
46011-2400	24	V-2	TIN
46011-2401	24	V-2	GOLD
46011-2402	24	V-0	TIN
46011-2403	24	V-0	GOLD

PART NUMBERS WITH VOIDED CIRCUITS

PART NUMBER	CIRCUIT SIZE	U.L. RATING	PLATING	VOIDED CIRCUITS
46011-5001	14	V-0	GOLD	4,11

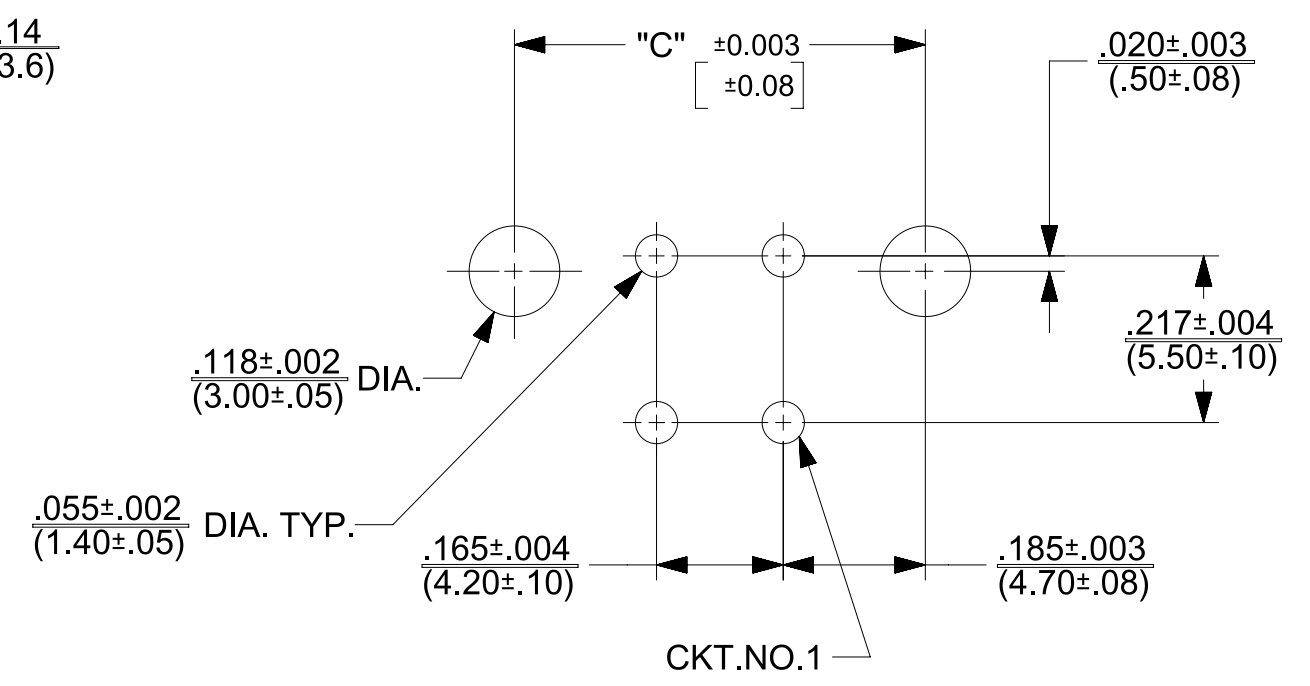
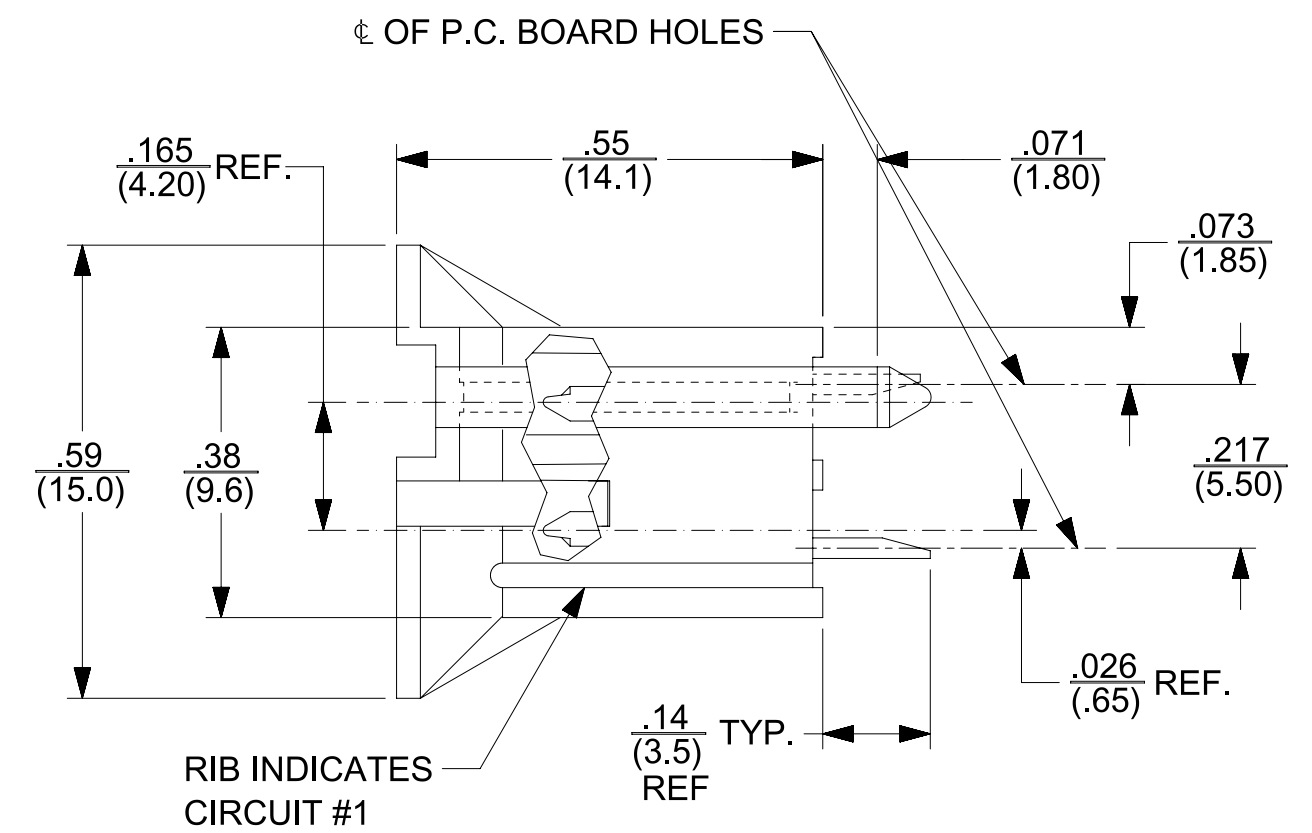
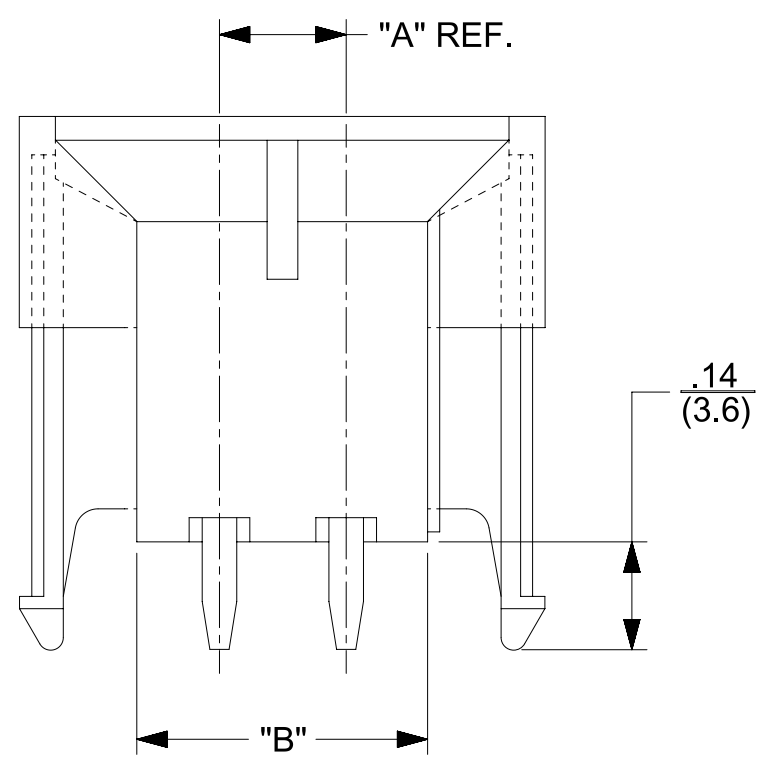
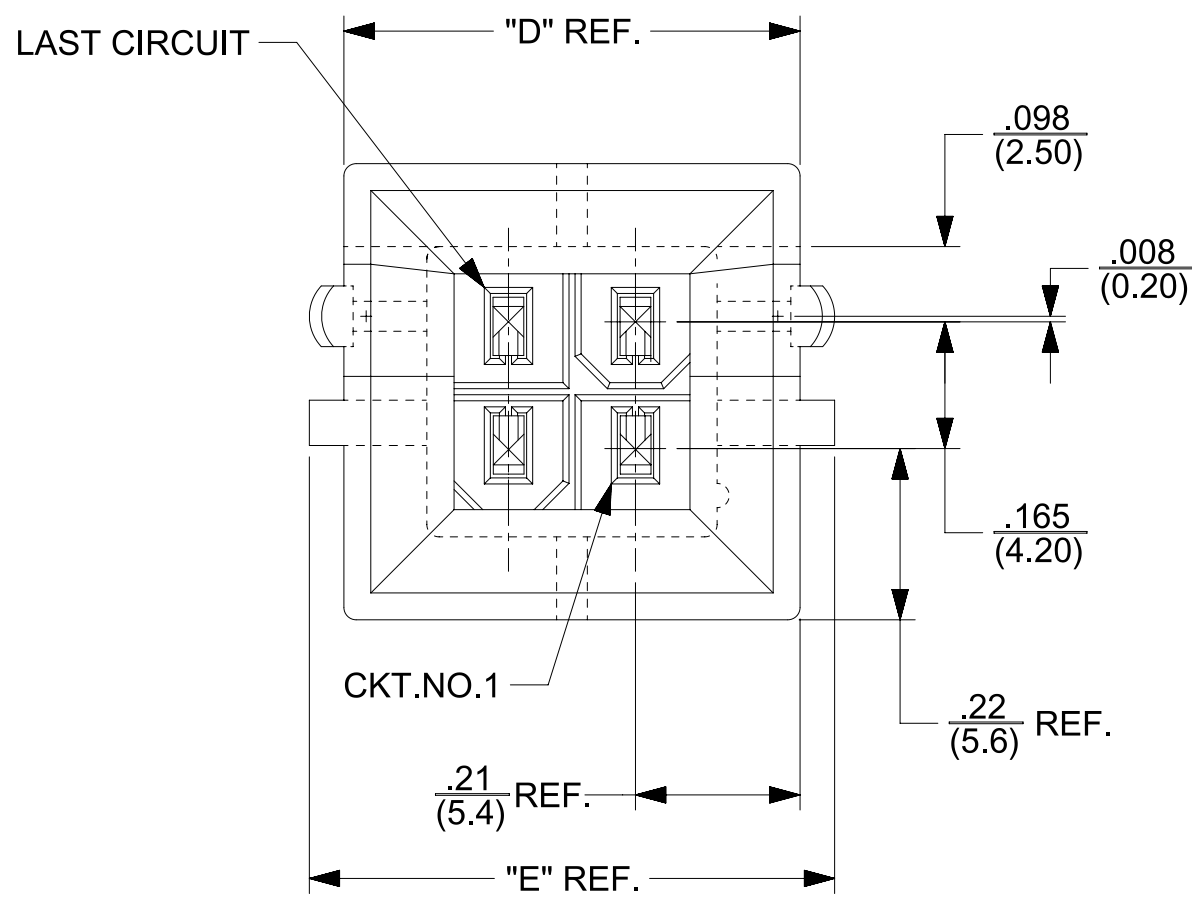

RECOMMENDED HOLE LAYOUT FOR .070(1.78) MAX. THICK P.C. BOARD

QUALITY SYMBOLS ▽ = 0 ▽ = 0 ▽ = 0 ▼ = 0 ▽ = 0 ☒ = 0 ■ = 0 ▽ = 0	THIS DRAWING CONTAINS INFORMATION THAT IS PROPRIETARY TO MOLEX INCORPORATED AND SHOULD NOT BE USED WITHOUT WRITTEN PERMISSION		DIMENSION UNITS IN/MM	SCALE 4:1					
	SEE SHEET 1 EC NO: 101245 DRWN: NK02 CHKD: APPR:	2015/09/07	GENERAL TOLERANCES (UNLESS SPECIFIED)	DRWN BY TGREGORI		DATE 2006/05/19	MINI-FIT VERTICAL BMI HEADER ASSEMBLY (HCS PLUS SERIES)		
			ANGULAR TOL ± 1/2 °	CHK'D BY JCOMERCI		DATE		PRODUCT CUSTOMER DRAWING	
			4 PLACES ± --	APPR BY JCOMERCI		DATE			SERIES 46011
3 PLACES ± --			DRAFT WHERE APPLICABLE MUST REMAIN WITHIN DIMENSIONS		DRAWING SIZE C	THIRD ANGLE PROJECTION			DOCUMENT NUMBER SD-46011-001