

SCAN18373T

Transparent Latch with TRI-STATE® Outputs

General Description

The SCAN18373T is a high speed, low-power transparent latch featuring separate data inputs organized into dual 9-bit bytes with byte-oriented latch enable and output enable control signals. This device is compliant with IEEE 1149.1 Standard Test Access Port and Boundary Scan Architecture with the incorporation of the defined boundary-scan test logic and test access port consisting of Test Data Input (TDI), Test Data Out (TDO), Test Mode Select (TMS), and Test Clock (TCK).

Features

- IEEE 1149.1 (JTAG) Compliant
- Buffered active-low latch enable
- TRI-STATE outputs for bus-oriented applications
- 9-bit data busses for parity applications
- Reduced-swing outputs source 32 mA/sink 64 mA (Comm), source 24 mA/sink 48 mA (Mil)
- Guaranteed to drive 50Ω transmission line to TTL input levels of 0.8V and 2.0V
- TTL compatible inputs
- 25 mil pitch SSOP (Shrink Small Outline Package)
- Includes CLAMP and HIGHZ instructions
- Member of National's SCAN Products

Ordering Code: See Section 11

Connection Diagram

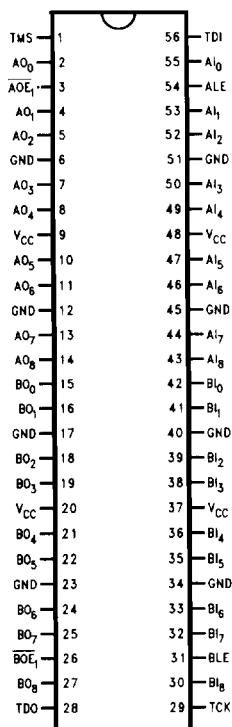

TL/F/10962-1

Pin Names	Description
AI(0-8), BI(0-8)	Data Inputs
ALE, BLE	Latch Enable Inputs
$\overline{AOE_1}$, $\overline{BOE_1}$	TRI-STATE Output Enable Inputs
AO(0-8), BO(0-8)	TRI-STATE Latch Outputs

Order Number	Description
SCAN18373TSSC	SSOP in Tubes
SCAN18373TSSCX	SSOP in Tape and Reel
SCAN18373TFMQB	Flatpak Military
5962-9311801MXA	Military SMD #

Truth Table

Inputs			AO (0-8)
ALE	$\overline{AOE_1}$	AI (0-8)	
X	H	X	Z
H	L	L	L
H	L	H	H
L	L	X	AO ₀

Inputs			BO (0-8)
BLE	$\overline{BOE_1}$	BI (0-8)	
X	H	X	Z
H	L	L	L
H	L	H	H
L	L	X	BO ₀

H = HIGH Voltage Level
 L = LOW Voltage Level
 X = Immaterial
 Z = High Impedance
 AO₀ = Previous AO before H-to-L transition of ALE
 BO₀ = Previous BO before H-to-L transition of BLE

Functional Description

The SCAN18373T consists of two sets of nine D-type latches with TRI-STATE standard outputs. When the Latch Enable (ALE or BLE) input is HIGH, data on the inputs (AI₍₀₋₈₎ or BI₍₀₋₈₎) enters the latches. In this condition the latches are transparent, i.e., a latch output will change state each time its input changes. When Latch Enable is LOW, the latches store the information that was present on the inputs a set-up time preceding the HIGH-to-LOW transition of the Latch Enable. The TRI-STATE standard outputs are controlled by the Output Enable ($\overline{AOE_1}$ or $\overline{BOE_1}$) input. When Output Enable is LOW, the standard outputs are in the 2-state mode. When Output Enable is HIGH, the standard outputs are in the high impedance mode, but this does not interfere with entering new data into the latches.

Logic Diagram

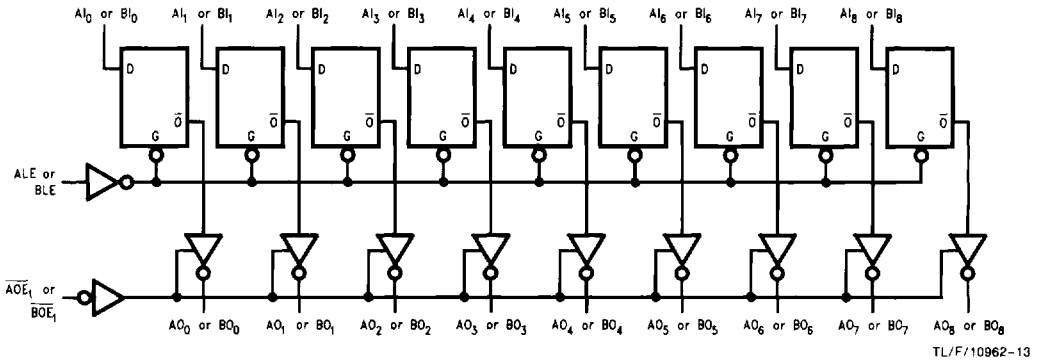

Please note that this diagram is provided only for the understanding of logic operations and should not be used to estimate propagation delays.

TL/F/10962-13

Block Diagrams

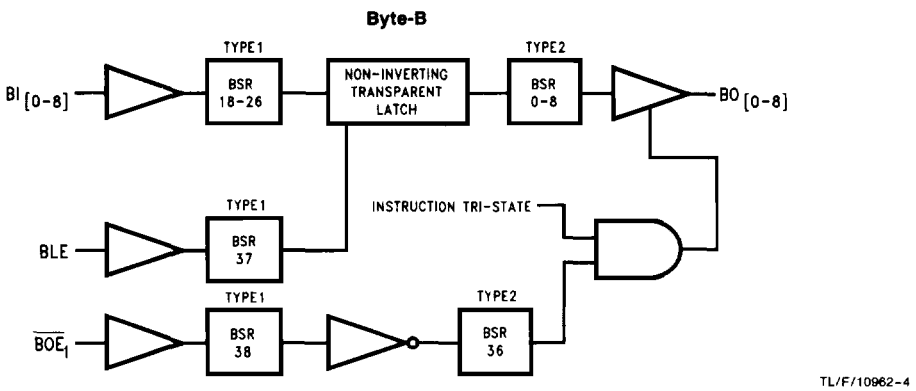
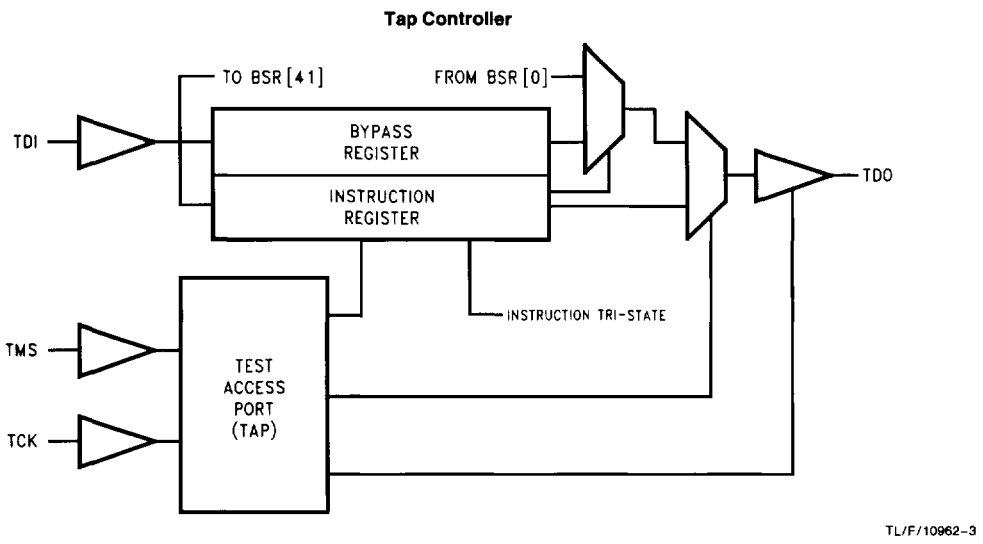
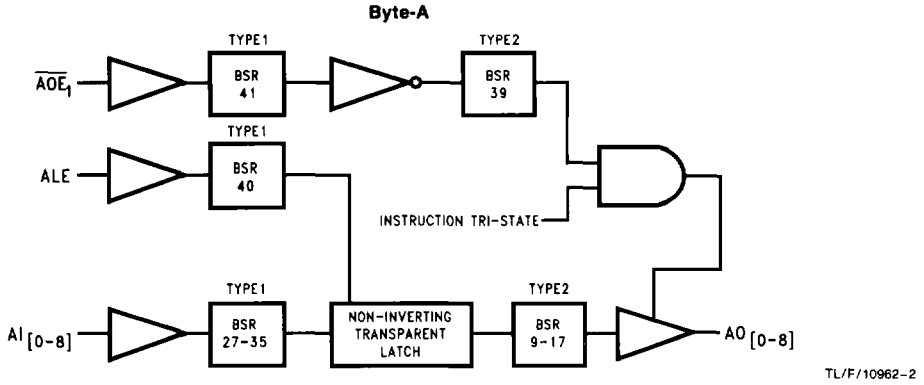

Note: BSR stands for Boundary Scan Register.

Description of Boundary-Scan Circuitry

The scan cells used in the BOUNDARY-SCAN register are one of the following two types depending upon their location. Scan cell TYPE1 is intended to solely observe system data, while TYPE2 has the additional ability to control system data. (See IEEE Standard 1149.1 *Figure 10-11* for a further description of scan cell TYPE1 and *Figure 10-12* for a further description of scan cell TYPE2.)

Scan cell TYPE1 is located on each system input pin while scan cell TYPE2 is located at each system output pin as well as at each of the two internal active-high output enable signals. AOE controls the activity of the A-outputs while BOE controls the activity of the B-outputs. Each will activate their respective outputs by loading a logic high.

The BYPASS register is a single bit shift register stage identical to scan cell TYPE1. It captures a fixed logic low.

The INSTRUCTION register is an eight-bit register which captures the value 00111101.

The two least significant bits of this captured value (01) are required by IEEE Std 1149.1. The upper six bits are unique to the SCAN18373T device. SCAN CMOS Test Access Logic devices do not include the IEEE 1149.1 optional identification register. Therefore, this unique captured value can be used as a "pseudo ID" code to confirm that the correct device is placed in the appropriate location in the boundary scan chain.

Instruction Register Scan Chain Definition

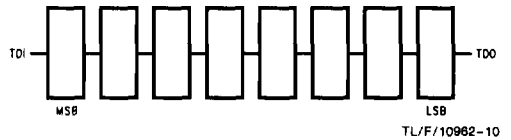

Bypass Register Scan Chain Definition

Logic 0

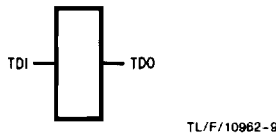

MSB → LSB

Instruction Code	Instruction
00000000	EXTTEST
10000001	SAMPLE/PRELOAD
10000010	CLAMP
00000011	HIGHZ
All Others	BYPASS

Scan Cell TYPE1

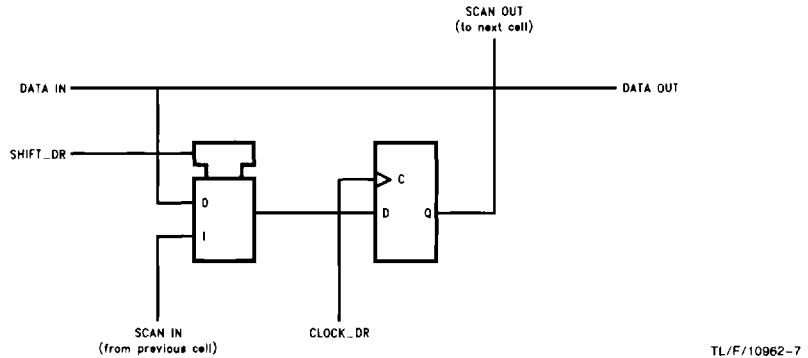

Scan Cell TYPE2

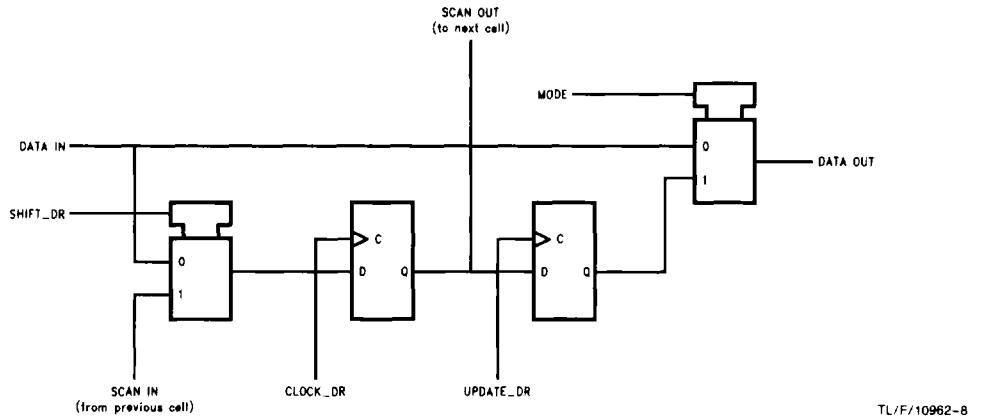

Description of Boundary-Scan Circuitry (Continued)

Boundary-Scan Register Scan Chain Definition (42 Bits in Length)

18373T

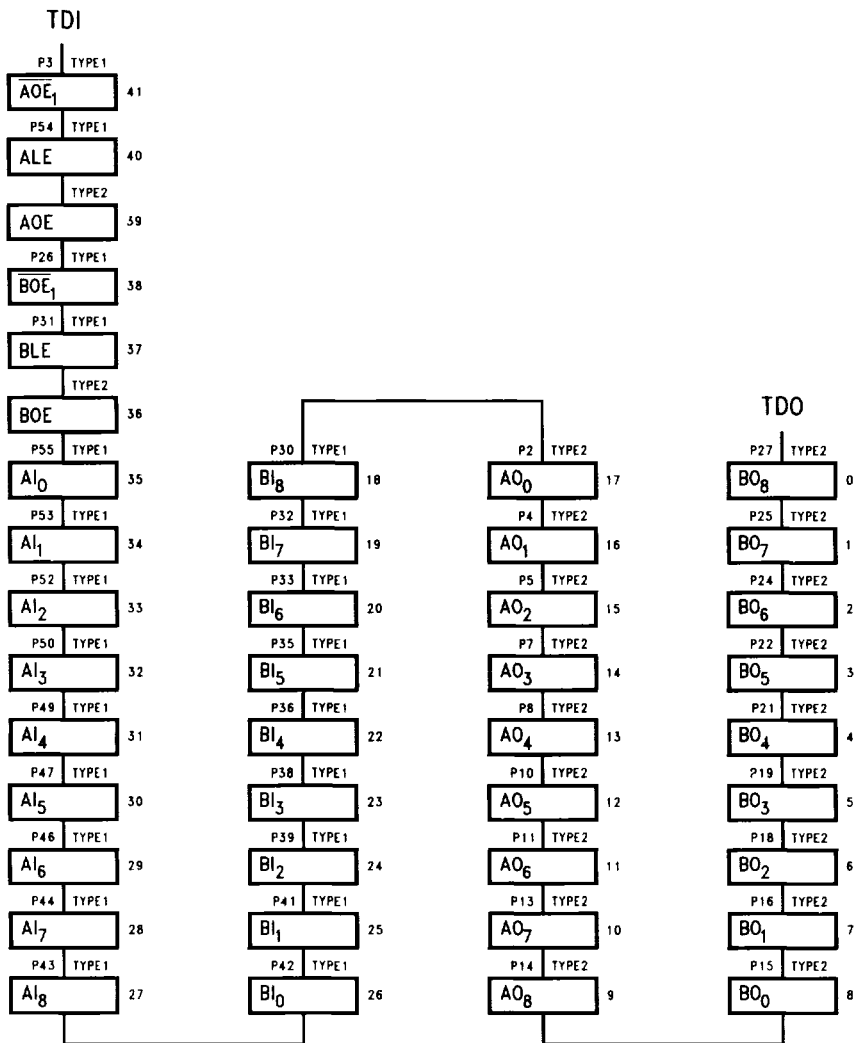

TL/F/10962-25

Description of Boundary-Scan Circuitry (Continued)
Boundary-Scan Register Definition Index

Bit No.	Pin Name	Pin No.	Pin Type	Scan Cell Type	
41	AOE ₁	3	Input	TYPE1	Control Signals
40	ACP	54	Input	TYPE1	
39	AOE		Internal	TYPE2	
38	BOE ₁	26	Input	TYPE1	
37	BCP	31	Input	TYPE1	
36	BOE		Internal	TYPE2	
35	AI ₀	55	Input	TYPE1	A-in
34	AI ₁	53	Input	TYPE1	
33	AI ₂	52	Input	TYPE1	
32	AI ₃	50	Input	TYPE1	
31	AI ₄	49	Input	TYPE1	
30	AI ₅	47	Input	TYPE1	
29	AI ₆	46	Input	TYPE1	
28	AI ₇	44	Input	TYPE1	
27	AI ₈	43	Input	TYPE1	
26	BI ₀	42	Input	TYPE1	B-in
25	BI ₁	41	Input	TYPE1	
24	BI ₂	39	Input	TYPE1	
23	BI ₃	38	Input	TYPE1	
22	BI ₄	36	Input	TYPE1	
21	BI ₅	35	Input	TYPE1	
20	BI ₆	33	Input	TYPE1	
19	BI ₇	32	Input	TYPE1	
18	BI ₈	30	Input	TYPE1	
17	AO ₀	2	Output	TYPE2	A-out
16	AO ₁	4	Output	TYPE2	
15	AO ₂	5	Output	TYPE2	
14	AO ₃	7	Output	TYPE2	
13	AO ₄	8	Output	TYPE2	
12	AO ₅	10	Output	TYPE2	
11	AO ₆	11	Output	TYPE2	
10	AO ₇	13	Output	TYPE2	
9	AO ₈	14	Output	TYPE2	
8	BO ₀	15	Output	TYPE2	B-out
7	BO ₁	16	Output	TYPE2	
6	BO ₂	18	Output	TYPE2	
5	BO ₃	19	Output	TYPE2	
4	BO ₄	21	Output	TYPE2	
3	BO ₅	22	Output	TYPE2	
2	BO ₆	24	Output	TYPE2	
1	BO ₇	25	Output	TYPE2	
0	BO ₈	27	Output	TYPE2	

Absolute Maximum Ratings (Note 1)

If Military/Aerospace specified devices are required, please contact the National Semiconductor Sales Office/Distributors for availability and specifications.

Supply Voltage (V_{CC})	-0.5V to +7.0V
DC Input Diode Current (I_{IK})	
$V_I = -0.5V$	-20 mA
$V_I = V_{CC} + 0.5V$	+20 mA
DC Output Diode Current (I_{OK})	
$V_O = -0.5V$	-20 mA
$V_O = V_{CC} + 0.5V$	+20 mA
DC Output Voltage (V_O)	-0.5V to $V_{CC} + 0.5V$
DC Output Source/Sink Current (I_O)	±70 mA
DC V_{CC} or Ground Current Per Output Pin	±70 mA
Junction Temperature SSOP	+140°C

Storage Temperature	-65°C to +150°C
ESD (Min)	2000V

Note 1: Absolute maximum ratings are those values beyond which damage to the device may occur. The databook specifications should be met, without exception, to ensure that the system design is reliable over its power supply, temperature, and output/input loading variables. National does not recommend operation of SCAN™ circuits outside databook specifications.

Recommended Operating Conditions

Supply Voltage (V_{CC})	
SCAN Products	4.5V to 5.5V
Input Voltage (V_I)	0V to V_{CC}
Output Voltage (V_O)	0V to V_{CC}
Operating Temperature (T_A)	
Commercial	-40°C to +85°C
Military	-55°C to +125°C
Minimum Input Edge Rate dV/dt	125 mV/ns
V_{IN} from 0.8V to 2.0V	
V_{CC} @ 4.5V, 5.5V	

DC Electrical Characteristics

Symbol	Parameter	V_{CC} (V)	Commercial		Military	Commercial		Units	Conditions
			$T_A = +25^\circ\text{C}$		$T_A = -55^\circ\text{C to } +125^\circ\text{C}$	$T_A = -40^\circ\text{C to } +85^\circ\text{C}$			
			Typ	Guaranteed Limits					
V_{IH}	Minimum High Input Voltage	4.5	1.5	2.0	2.0	2.0	2.0	V	$V_{OUT} = 0.1V$ or $V_{CC} - 0.1V$
		5.5	1.5	2.0	2.0	2.0	2.0		
V_{IL}	Maximum Low Input Voltage	4.5	1.5	0.8	0.8	0.8	0.8	V	$V_{OUT} = 0.1V$ or $V_{CC} - 0.1V$
		5.5	1.5	0.8	0.8	0.8	0.8		
V_{OH}	Minimum High Output Voltage	4.5		3.15	3.15	3.15	3.15	V	$I_{OUT} = -50 \mu\text{A}$
		5.5		4.15	4.15	4.15	4.15		
		4.5		2.4			2.4	V	$V_{IN} = V_{IL}$ or V_{IH} $I_{OH} = -32 \text{ mA}$
		5.5		2.4			2.4		
		4.5		2.4	2.4			V	$V_{IN} = V_{IL}$ or V_{IH} $I_{OH} = -24 \text{ mA}$
		5.5		2.4	2.4				
V_{OL}	Maximum Low Output Voltage	4.5		0.1	0.1	0.1	0.1	V	$I_{OUT} = 50 \mu\text{A}$
		5.5		0.1	0.1	0.1	0.1		
		4.5		0.55			0.55	V	$V_{IN} = V_{IL}$ or V_{IH} $I_{OL} = 64 \text{ mA}$
		5.5		0.55			0.55		
		4.5		0.55	0.55			V	$V_{IN} = V_{IL}$ or V_{IH} $I_{OL} = 48 \text{ mA}$
		5.5		0.55	0.55				
I_{IN}	Maximum Input Leakage Current	5.5		±0.1	±1.0	±1.0	μA	$V_I = V_{CC}, \text{GND}$	
I_{IN} TDI, TMS	Maximum Input Leakage	5.5		2.8	3.7	3.6	μA	$V_I = V_{CC}$	
				-385	-385	-385	μA	$V_I = \text{GND}$	
	Minimum Input Leakage	5.5		-160	-160	-160	μA	$V_I = \text{GND}$	
I_{OLD}	†Minimum Dynamic Output Current	5.5		94	63	94	mA	$V_{OLD} = 0.8V \text{ Max}$	
I_{OHD}				-40	-27	-40	mA	$V_{OHD} = 2.0V \text{ Min}$	

†Maximum test duration 2.0 ms, one output loaded at a time.

DC Electrical Characteristics (Continued)

Symbol	Parameter	V _{CC} (V)	Commercial		Military	Commercial		Units	Conditions
			T _A = +25°C		T _A = -55°C to +125°C	T _A = -40°C to +85°C			
			Typ	Guaranteed Limits					
I _{OZ}	Maximum Output Leakage Current	5.5		±0.5	±10.0		±5.0	μA	V _I (OE) = V _{IL} , V _{IH}
I _{OS}	Output Short Circuit Current	5.5		-100	-100		-100	mA Min	V _O = 0V
I _{CC}	Maximum Quiescent Supply Current	5.5		16.0	168		88	μA	V _O = Open TDI, TMS = V _{CC}
		5.5		750	930		820	μA	V _O = Open TDI, TMS = GND
I _{CCt}	Maximum I _{CC} per Input	5.5		2.0	2.0		2.0	mA	V _I = V _{CC} - 2.1V
		5.5		2.15	2.15		2.15	mA	V _I = V _{CC} - 2.1V TDI/TMS Pin, Test One with the Other Floating

*All outputs loaded; thresholds associated with output under test.

†Maximum test duration 2.0 ms, one output loaded at a time.

Noise Specifications: See Section 4

Symbol	Parameter	V _{CC} (V)	Commercial		Military	Commercial		Units	Fig. No.
			T _A = +25°C		T _A = -55°C to +125°C	T _A = -40°C to +85°C			
			Typ	Guaranteed Limits					
V _{OLP}	Maximum High Output Noise (Notes 2, 3)	5.0	1.0	1.5				V	4-13
V _{OLV}	Minimum Low Output Noise (Notes 2, 3)	5.0	-0.6	-1.2				V	4-13
V _{OHP}	Maximum Overshoot (Notes 1, 3)	5.0	V _{OH} + 1.0	V _{OH} + 1.5				V	4-13
V _{OHV}	Minimum V _{CC} Droop (Notes 1, 3)	5.0	V _{OH} - 1.0	V _{OH} - 1.8				V	4-13
V _{IHD}	Minimum High Dynamic Input Voltage Level (Notes 1, 4)	5.5	1.6	2.0	2.0		2.0	V	
V _{ILD}	Maximum Low Dynamic Input Voltage Level (Notes 1, 4)	5.5	1.4	0.8	0.8		0.8	V	

Note 1: Worst case package.

Note 2: Maximum number of outputs that can switch simultaneously is n. (n-1) outputs are switched LOW and one output held LOW.

Note 3: Maximum number of outputs that can switch simultaneously is n. (n-1) outputs are switched HIGH and one output held HIGH.

Note 4: Maximum number of data inputs (n) switching. (n-1) input switching 0V to 3V. Input under test switching 3V to threshold (V_{ILD}).

AC Electrical Characteristics

Normal Operation: See Section 4

Symbol	Parameter	V _{CC} * (V)	Commercial		Military		Commercial		Units	Fig. No.
			T _A = +25°C C _L = 50 pF		T _A = -55°C to +125°C C _L = 50 pF		T _A = -40°C to +85°C C _L = 50 pF			
			Min	Typ Max	Min	Max	Min	Max		
t _{PLH} , t _{PHL}	Propagation Delay, D to Q	5.0	2.5 2.5	9.0 9.0	2.5 2.5	10.5 10.5	2.5 2.5	9.8 9.8	ns	4-1, 2
t _{PLH} , t _{PHL}	Propagation Delay, LE to Q	5.0	2.5 2.5	10.0 10.5	2.5 2.5	11.0 12.0	2.5 2.5	10.5 11.3	ns	4-1, 2
t _{PLZ} , t _{PHZ}	Disable Time	5.0	1.5 1.5	9.0 9.5	1.5 1.5	10.5 10.3	1.5 1.5	9.5 10.0	ns	4-3, 4
t _{PZL} , t _{PZH}	Enable Time	5.0	2.0 2.0	10.9 9.0	2.0 2.0	12.8 10.6	2.0 2.0	11.9 9.7	ns	4-3, 4

*Voltage Range 5.0 is 5.0V ± 0.5V.

AC Operating Requirements

Normal Operation: See Section 4

Symbol	Parameter	V _{CC} * (V)	Commercial		Military		Commercial		Units	Fig. No.
			T _A = +25°C C _L = 50 pF		T _A = -55°C to +125°C C _L = 50 pF		T _A = -40°C to +85°C C _L = 50 pF			
			Guaranteed Minimum							
t _S	Setup Time, H or L Data to LE	5.0	3.0		3.0		3.0		ns	4-5
t _H	Hold Time, H or L LE to Data	5.0	1.5		1.5		1.5		ns	4-5
t _w	LE Pulse Width	5.0	5.0		5.0		5.0		ns	4-2

*Voltage Range 5.0 is 5.0V ± 0.5V.

AC Electrical Characteristics

Scan Test Operation: See Section 4

Symbol	Parameter	V _{CC} [*] (V)	Commercial			Military		Commercial		Units	Fig. No.
			T _A = +25°C C _L = 50 pF			T _A = -55°C to +125°C C _L = 50 pF		T _A = -40°C to +85°C C _L = 50 pF			
			Min	Typ	Max	Min	Max	Min	Max		
t _{PLH} , t _{PHL}	Propagation Delay TCK to TDO	5.0	3.5	13.2	3.5	15.8	3.5	14.5	ns	4-8	
t _{PLZ} , t _{PHZ}	Disable Time TCK to TDO	5.0	2.5	11.5	2.5	12.8	2.5	11.9	ns	4-9, 10	
t _{PZL} , t _{PZH}	Enable Time TCK to TDO	5.0	3.0	14.5	3.0	16.7	3.0	15.8	ns	4-9, 10	
t _{PLH} , t _{PHL}	Propagation Delay TCK to Data Out during Update-DR State	5.0	5.0	18.0	5.0	21.7	5.0	19.8	ns	4-8	
t _{PLH} , t _{PHL}	Propagation Delay TCK to Data Out during Update-IR State	5.0	5.0	18.6	5.0	21.2	5.0	20.2	ns	4-8	
t _{PLH} , t _{PHL}	Propagation Delay TCK to Data Out during Test Logic Reset State	5.0	5.5	19.9	5.5	23.0	5.5	21.5	ns	4-8	
t _{PLZ} , t _{PHZ}	Propagation Delay TCK to Data Out during Update-DR State	5.0	4.0	16.4	4.0	19.6	4.0	18.2	ns	4-9, 10	
t _{PLZ} , t _{PHZ}	Propagation Delay TCK to Data Out during Update-IR State	5.0	5.0	19.5	5.0	22.4	5.0	20.8	ns	4-9, 10	
t _{PLZ} , t _{PHZ}	Propagation Delay TCK to Data Out during Test Logic Reset State	5.0	5.0	19.9	5.0	23.3	5.0	21.5	ns	4-9, 10	
t _{PZL} , t _{PZH}	Propagation Delay TCK to Data Out during Update-DR State	5.0	5.0	18.9	5.0	22.6	5.0	20.9	ns	4-9, 10	
t _{PZL} , t _{PZH}	Propagation Delay TCK to Data Out during Update-IR State	5.0	6.5	22.4	6.5	26.2	6.5	24.2	ns	4-9, 10	
t _{PZL} , t _{PZH}	Propagation Delay TCK to Data Out during Test Logic Reset State	5.0	7.0	23.8	7.0	27.4	7.0	25.7	ns	4-9, 10	

*Voltage Range 5.0 is 5.0V ± 0.5V

All propagation delays involving TCK are measured from the falling edge of TCK.

AC Operating Requirements Scan Test Operation: See Section 4

Symbol	Parameter	V _{CC} * (V)	Commercial	Military	Commercial	Units	Fig. No.	
			T _A = +25°C C _L = 50 pF	T _A = -55°C to +125°C C _L = 50 pF	T _A = -40°C to +85°C C _L = 50 pF			
			Guaranteed Minimum					
t _S	Setup Time, Data to TCK (Note 2)	5.0	3.0	3.0	3.0	ns	4-11	
t _H	Hold Time, TCK to Data (Note 2)	5.0	4.5	4.5	4.5	ns	4-11	
t _S	Setup Time, H or L A _{OE1} , B _{OE1} to TCK (Note 4)	5.0	3.0	3.0	3.0	ns	4-11	
t _H	Hold Time, H or L TCK to A _{OE1} , B _{OE1} (Note 4)	5.0	4.5	5.0	4.5	ns	4-11	
t _S	Setup Time, H or L Internal AOE, BOE, to TCK (Note 3)	5.0	3.0	3.0	3.0	ns	4-11	
t _H	Hold Time, H or L TCK to Internal AOE, BOE (Note 3)	5.0	3.0	3.0	3.0	ns	4-11	
t _S	Setup Time ALE, BLE (Note 1) to TCK	5.0	3.0	3.0	3.0	ns	4-11	
t _H	Hold Time TCK to ALE, BLE (Note 1)	5.0	3.5	4.0	3.5	ns	4-11	
t _S	Setup Time, H or L TMS to TCK	5.0	8.0	8.0	8.0	ns	4-11	
t _H	Hold Time, H or L TCK to TMS	5.0	2.0	2.0	2.0	ns	4-11	
t _S	Setup Time, H or L TDI to TCK	5.0	4.0	4.0	4.0	ns	4-11	
t _H	Hold Time, H or L TCK to TDI	5.0	4.5	4.5	4.5	ns	4-11	
t _W	Pulse Width TCK	5.0	H	15.0	15.0	15.0	ns	4-12
			L	5.0	5.0	5.0		
f _{max}	Maximum TCK Clock Frequency	5.0	25	25	25	MHz		
T _{pu}	Wait Time, Power Up to TCK	5.0	100	100	100	ns		
T _{dn}	Power Down Delay	0.0	100	100	100	ms		

*Voltage Range 5.0 is 5.0V ± 0.5V.

All Input Timing Delays involving TCK are measured from the rising edge of TCK.

Note 1: Timing pertains to BSR 37 and 40 only.

Note 2: This delay represents the timing relationship between the data input and TCK at the associated scan cells numbered 0-8, 9-17, 18-26 and 27-35.

Note 3: This delay represents the timing relationship between AOE/BOE and TCK for scan cells 38 and 39 only.

Note 4: Timing pertains to BSR 38 and 41 only.

Extended AC Electrical Characteristics: See Section 4

Symbol	Parameter	T _A = Com V _{CC} = Com C _L = 50 pF 18 Outputs Switching (Note 2)			T _A = Mil V _{CC} = Mil C _L = 50 pF 18 Outputs Switching (Note 2)		T _A = Com V _{CC} = Com C _L = 250 pF (Note 3)		T _A = Mil V _{CC} = Mil C _L = 250 pF (Note 3)		Units
		Min	Typ	Max	Min	Max	Min	Max	Min	Max	
t _{PLH} t _{PHL}	Propagation Delay Latch Enable to Output	3.0		12.0	3.0	12.5	4.0	13.5	4.0	14.5	ns
		3.0		12.8	3.0	13.5	4.0	16.0	4.0	16.5	
t _{PLH} t _{PHL}	Propagation Delay Data to Output	3.0		11.5	3.0	12.0	4.0	13.0	4.0	14.0	ns
		3.0		11.5	3.0	12.0	4.0	14.5	4.0	15.5	
t _{PZH} t _{PZL}	Output Enable Time	2.5		10.5	2.5	11.0	(Note 4)		(Note 4)		ns
		2.5		12.5	2.5	13.5					
t _{PHZ} t _{PLZ}	Output Disable Time	2.0		10.5	2.0	11.0	(Note 5)		(Note 5)		ns
		2.0		10.5	2.0	11.0					
t _{OSSL} (Note 1)	Pin to Pin Skew HL Data to Output		0.5	1.0			1.0				ns
t _{OSLH} (Note 1)	Pin to Pin Skew LH Data to Output		0.5	1.0			1.0				ns

Note 1: Skew is defined as the absolute value of the difference between the actual propagation delays for any two separate outputs of the same device. The specification applies to any outputs switching HIGH to LOW (t_{OSSL}), LOW to HIGH (t_{OSLH}), or any combination switching LOW to HIGH.

Note 2: This specification is guaranteed but not tested. The limits apply to propagation delays for all paths described switching in phase (i.e., all low-to-high, high-to-low, etc.).

Note 3: This specification is guaranteed but not tested. The limits represent propagation delays with 250 pF load capacitors in place of the 50 pF load capacitors in the standard AC load. This specification pertains to single output switching only.

Note 4: TRI-STATE delays are load dominated and have been excluded from the datasheet.

Note 5: The Output Disable Time is dominated by the RC network (500Ω, 250 pF) on the output and has been excluded from the datasheet.

Capacitance

Symbol	Parameter	Typ	Units	Conditions
C _{IN}	Input Pin Capacitance	4.0	pF	V _{CC} = 5.0V
C _{OUT}	Output Pin Capacitance	13.0	pF	V _{CC} = 5.0V
C _{PD}	Power Dissipation Capacitance	34.0	pF	V _{CC} = 5.0V