

# MGA-231T6

## High-Gain GPS LNA

### with Variable Current and Shutdown Function



## Data Sheet

### Description

Avago Technologies' MGA-231T6 is a low-noise amplifier (LNA) designed for GPS/ISM/Wimax applications in the (0.9-3.5)GHz frequency range. The LNA uses Avago Technologies' proprietary GaAs Enhancement-mode pHEMT process to achieve high gain with very low noise figure and high linearity. Noise figure distribution is very tightly controlled. A CMOS-compatible shutdown pin is included either for turning the LNA on/off or for current adjustment.

The low noise figure and high gain, coupled with low current consumption make it suitable for use in critical low-power GPS applications or during low-battery situations.

### Component Image

Surface Mount 2.0x1.3x0.4 mm<sup>3</sup> 6-lead UTSLP

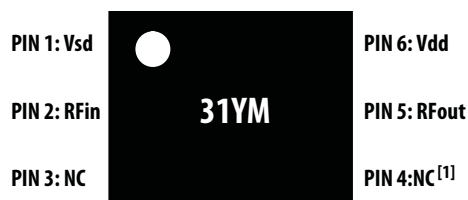

Top View

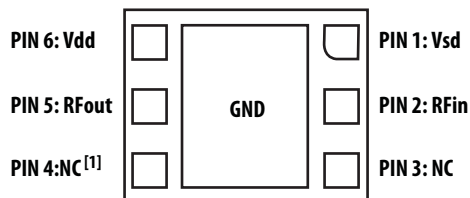

Bottom View

Note:

1. Pin 4 must be left unconnected
2. Package marking provides orientation and identification  
 "31" = Product Code  
 "Y" = Year of manufacture  
 "M" = Month code of manufacture

### Features

- Very Low Noise Figure
- High Gain and Linearity
- Low External Component Count
- Low Shutdown Current
- CMOS compatible shutdown pin (SD) current @ Vsd= 1.8V : 0.11mA
- Useable down to 1.8V supply
- Adjustable current via single external resistor/voltage
- Small package dimension: 2.0(L)x1.3(W)x0.4(H) mm

### Specifications (Typical performance @ 25°C)

#### At 1.575GHz

- Vdd = 2.85V, Vsd = 1.8V, Idd = 4mA
  - Gain = 17.1 dB
  - NF = 1.06 dB
  - Input IP3 = 0.2 dBm
  - Input P1dB = 7.7 dBm

### Application

- LNA for GPS, WLAN and WIMAX

### Absolute Maximum Rating<sup>[1]</sup> $T_A = 25^\circ\text{C}$

Symbol	Parameter	Units	Absolute Max.
Vdd	Device Drain to Source Voltage <sup>[2]</sup>	V	3.6
Idd	Drain Current <sup>[2]</sup>	mA	15
P <sub>in,max</sub>	CW RF Input Power (Vdd = 2.7V, Idd = 6mA)	dBm	13
P <sub>diss</sub>	Total Power Dissipation <sup>[4]</sup>	mW	54
T <sub>C</sub> <sup>[5]</sup>	Recommended Operating Temperature <sup>[6]</sup>	°C	-40 to +85
T <sub>j</sub>	Junction Temperature	°C	150
T <sub>STG</sub>	Storage Temperature	°C	-65 to 150

Thermal Resistance<sup>[3]</sup>  
(Vdd = 2.85V, Vsd = 1.8V,  
Idd = 4mA),  $\theta_{jc} = 150.8^\circ\text{C/W}$

Notes:

1. Operation of this device in excess of any of these limits may cause permanent damage.
2. Assuming DC quiescent conditions.
3. Thermal resistance measured using Infra-Red measurement technique.
4. Board (module belly) temperature TB is 25°C. Derate 6.63 mW/°C for Tb > 141.86°C
5. T<sub>C</sub> is defined as case temperature, the temperature of the underside of the device where it makes contact with the circuit board
6. The device will function over the recommended range without degradation in reliability or permanent change in performance, but is not guaranteed to meet the electrical specification.

### Product Consistency Distribution Chart<sup>[7,8]</sup> (Vdd=2.85V, Vsd = 1.8V, R2 = 8.2kohm, Freq = 1.575GHz)

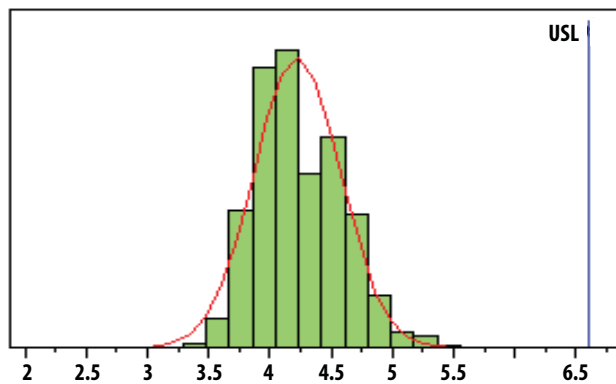

Figure 1. Id (mA) distribution

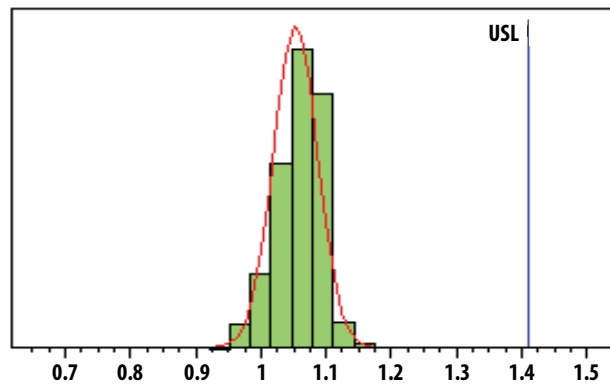

Figure 2. NF (dB) distribution

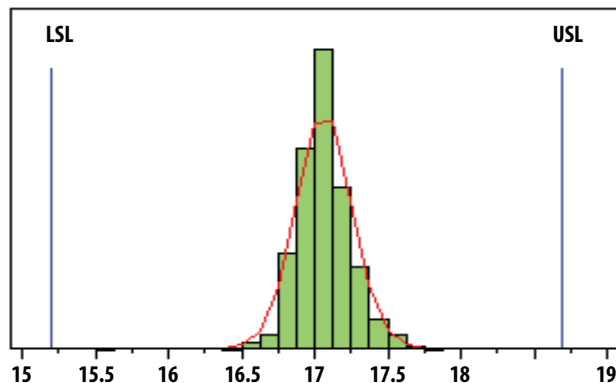

Figure 3. Gain (dB) distribution

Notes:

7. Distribution data sample size is 500 samples taken from 3 different lots. Future wafers allocated to this product may have nominal values anywhere between the upper and lower limits.
8. Measurements are made on a production test board, which represents a trade-off between optimal Gain, NF, IIP3, IP1dB and VSWR. Circuit trace losses have not been de-embedded from actual measurements.

## Electrical Specifications

$T_A = 25^\circ\text{C}$ , DC bias for RF parameters is as specified below. Freq=1.575GHz – Typical Performance<sup>[1]</sup>

**Table 1a. Performance table under nominal operating conditions (Vdd = 2.85V, Vsd = 1.8V, Idd = 4mA, R2 = 8.2 kOhm)**

Symbol	Parameter and Test Condition	Units	Min.	Typ	Max.
G	Gain	dB	15.2	17.1	18.7
NF <sup>[1]</sup>	Noise Figure <sup>[1]</sup>	dB	–	1.06	1.41
IP1dB	Input 1dB Compressed Power	dBm	–	-7.7	–
IIP3 <sup>[3]</sup>	Input 3 <sup>rd</sup> Order Intercept Point (2-tone @ Fc +/- 2.5MHz)	dBm	–	0.2	–
S11	Input Return Loss	dB	–	-10	–
S22	Output Return Loss	dB	–	-10	–
S12	Reverse Isolation	dB	–	-29	–
Idd	Supply DC current at Shutdown (SD) voltage Vsd=2.7V	mA	–	4	6.6
Ish	Shutdown Current @ VSD = 0V	uA	–	0.4	–

**Table 1b. Performance table under nominal operating conditions (Vdd = 1.8V, Vsd = 2.6V, Idd = 3.5mA, R2 = 8.2 kOhm)**

Symbol	Parameter and Test Condition	Units	Min.	Typ	Max.
G	Gain	dB	–	16.6	–
NF <sup>[1]</sup>	Noise Figure	dB	–	1.1	–
IP1dB	Input 1dB Compressed Power	dBm	–	-7.5	–
IIP3 <sup>[3]</sup>	Input 3 <sup>rd</sup> Order Intercept Point (2-tone @ Fc +/- 2.5MHz)	dBm	–	0	–
S11	Input Return Loss	dB	–	-10	–
S22	Output Return Loss	dB	–	-10	–
S12	Reverse Isolation	dB	–	-28	–
Idd	Supply DC current at Shutdown (SD) voltage Vsd=2.7V	mA	–	3.5	–
Ish	Shutdown Current @ VSD = 0V	uA	–	0.2	–

**Table 1c. Performance table under nominal operating conditions (Vdd = Vsd = 2.7V, Idd = 6mA, R2 = 5.6 kOhm)**

Symbol	Parameter and Test Condition	Units	Min.	Typ	Max.
G	Gain	dB	–	17.9	–
NF <sup>[1]</sup>	Noise Figure	dB	–	1.0	–
IP1dB	Input 1dB Compressed Power	dBm	–	-5.9	–
IIP3 <sup>[3]</sup>	Input 3 <sup>rd</sup> Order Intercept Point (2-tone @ Fc +/- 2.5MHz)	dBm	–	+2.7	–
S11	Input Return Loss	dB	–	-11	–
S22	Output Return Loss	dB	–	-11	–
S12	Reverse Isolation	dB	–	-29	–
Idd	Supply DC current at Shutdown (SD) voltage Vsd=2.7V	mA	–	6	–
Ish	Shutdown Current @ VSD = 0V	uA	–	0.3	–

Notes:

1. NF is measured at DUT input leads with board loss deembedded.
2. Measurements at 1.575GHz obtained using demo board described in Figures 4.
3. 1.575GHz IIP3 test condition:  $F_{RF1} = 1572.5 \text{ MHz}$ ,  $F_{RF2} = 1577.5 \text{ MHz}$  with input power of -20dBm per tone measured at the worst case side band.

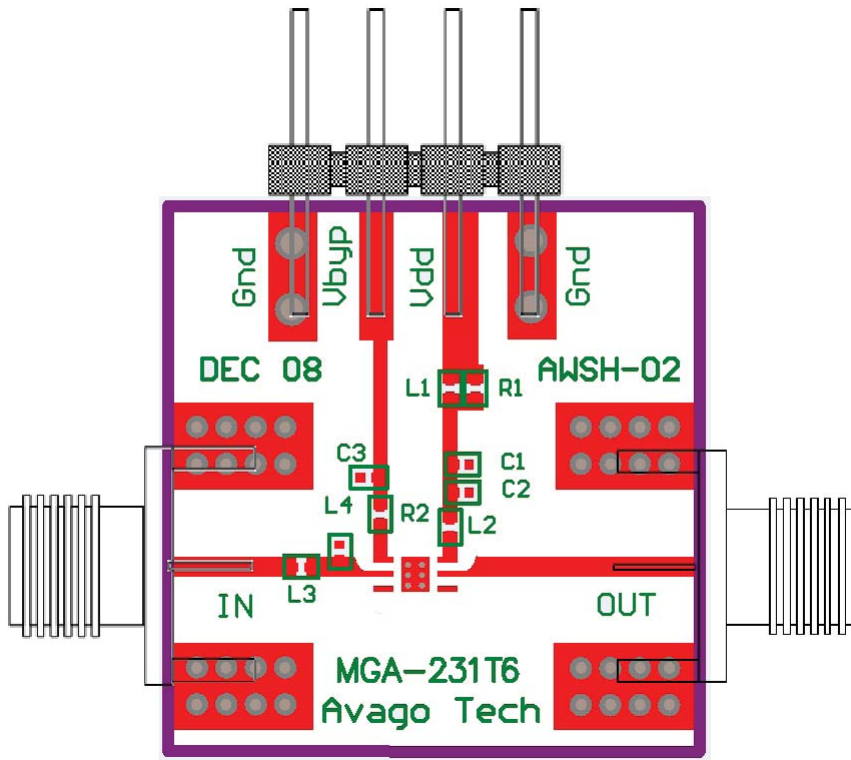

Circuit Symbol	Size	Description
L1	0201	22nH Inductor (Murata LQP03TN22NH00)
L2	0201	2.6nH Inductor (Murata LQP03TN2N6B00)
L3	0201	10nH Inductor (Murata LQP03TN10NH00)
L4	0201	39nH Inductor (Murata LQP03TN39NJ00)
C1	0201	0.1uF Capacitor (Murata GRM033R60J104K)
C2	0201	47pF Capacitor (Murata GRM0335C1E470J)
C3	0201	330pF Capacitor (Murata GRM033R71E331K)
R1	0201	10ohm Resistor
R2	0201	8.2Kohm Resistor (For biasing condition as stated in Table 1a/b) 5.6Kohm Resistor (For biasing condition as stated in Table 1c)

Figure 4. Demo Board and application circuit components table

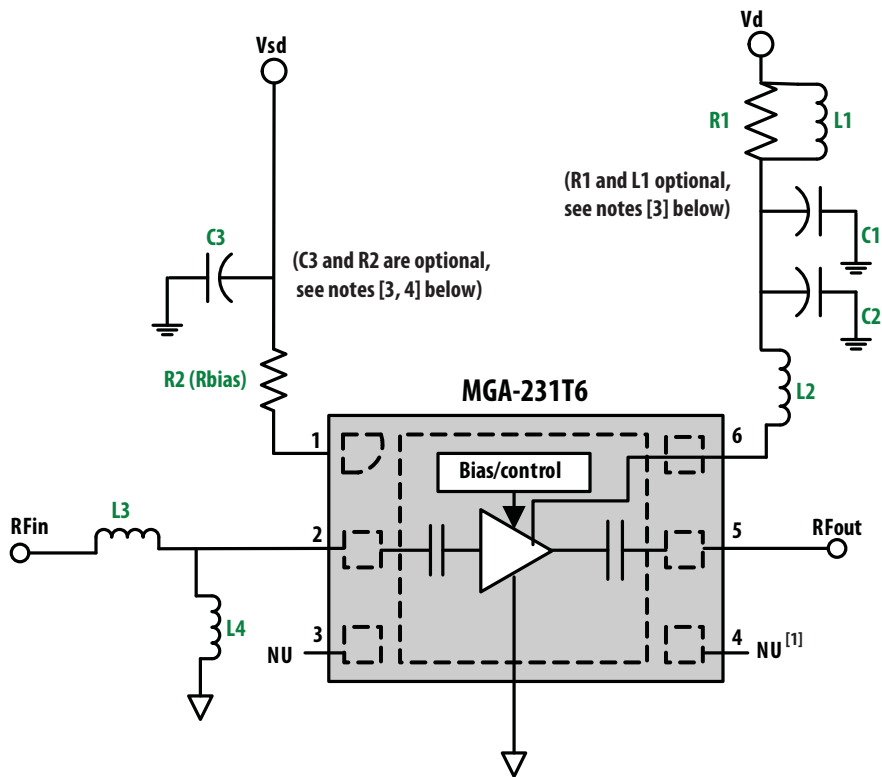

Notes:

1. Pin 4 must be left unconnected
2. L3 and L4 form the input matching network. C2 and L2 form a matching network at the output of the LNA.
3. L1 and R1 isolates the demoboard from external disturbances during measurement. It is not needed in actual application. Likewise, C1 and C3 mitigate the effect of external noise pickup on the Vdd and SD lines respectively. These components are not required in actual operation.
4. Bias control is achieved by either varying the SD voltage with/without R2, or fixing the SD voltage to Vdd and adjusting R2 for the desired current. R2 = 8.2 kOhm will result in 4mA when Vdd = 2.85V, Vsd = 1.8V or Vdd = 1.8V, Vsd = 2.6V. R2 = 5.6 kOhm will result in 6mA when Vdd = Vsd = 2.7V.

Figure 5. Demo board and application schematic diagram

**MGA-231T6 Typical Performance Curves at 25°C, R2 = 8.2Kohm (unless specified otherwise)**

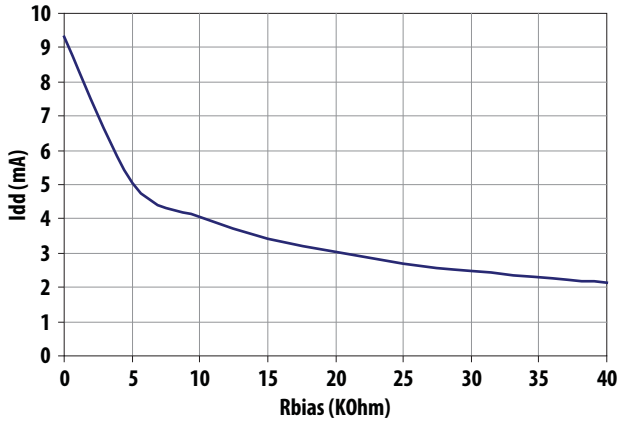

Figure 6. Idd vs Rbias at Vdd= 2.85V, Vsd =1.8V

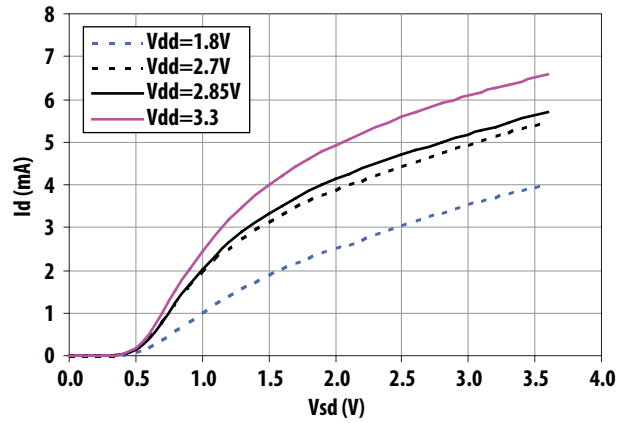

Figure 7. Idd vs Vsd vs Vdd

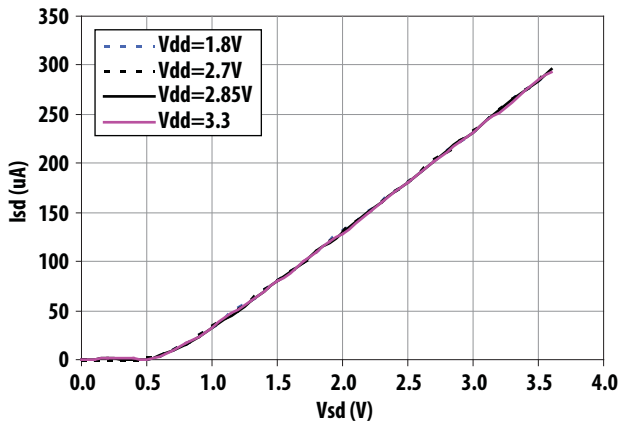

Figure 8. Isd vs Vsd vs Vdd

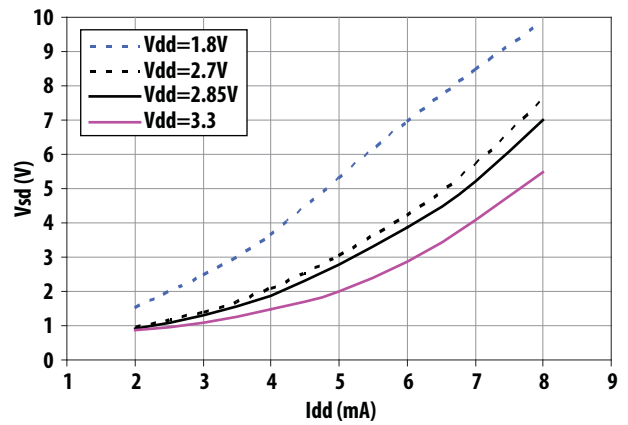

Figure 9. Vsd vs Idd vs Vdd

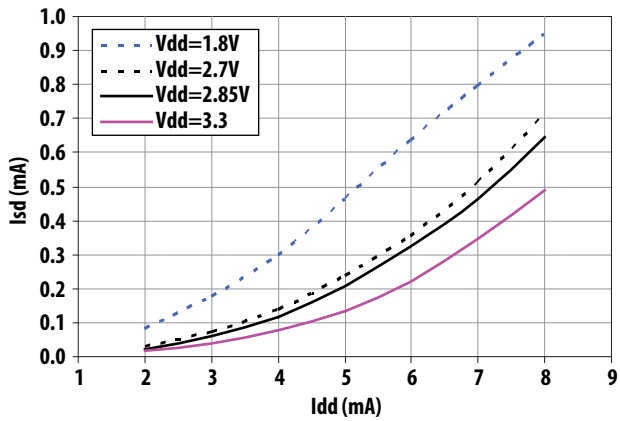

Figure 10. Isd vs Idd vs Vdd

**MGA-231T6 Typical Performance Curves at 25°C, R2 = 8.2Kohm, Vdd = 2.85V, Vsd = 1.8V (unless specified otherwise)**

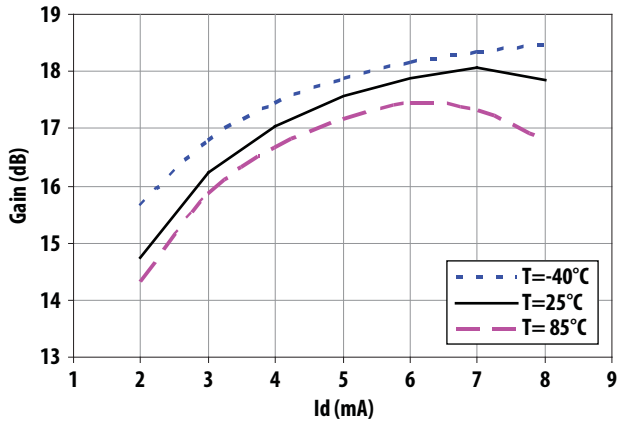

Figure11. Gain vs Idd vs Temp

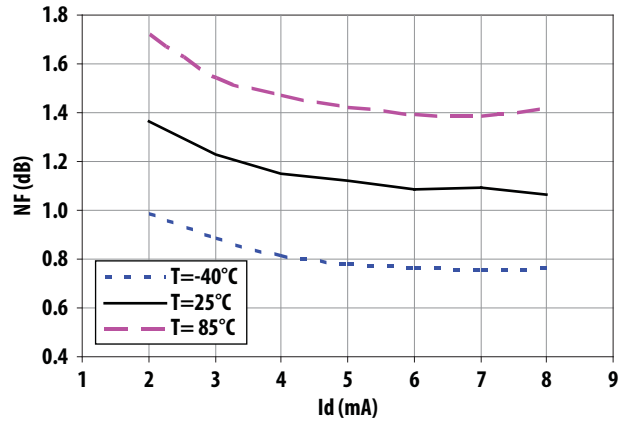

Figure 12. NF vs Idd vs Temp

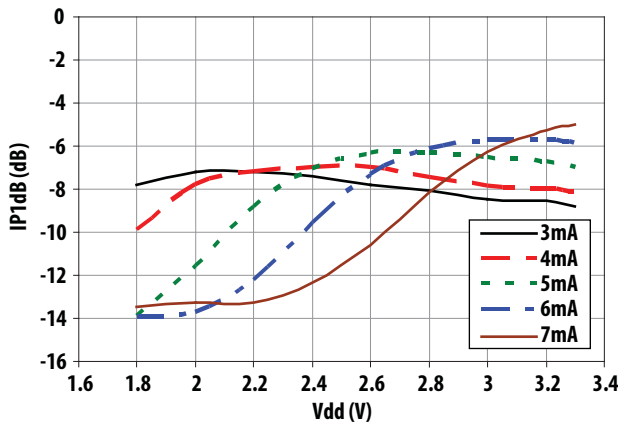

Figure 13. IP1dB vs Vdd vs Idd

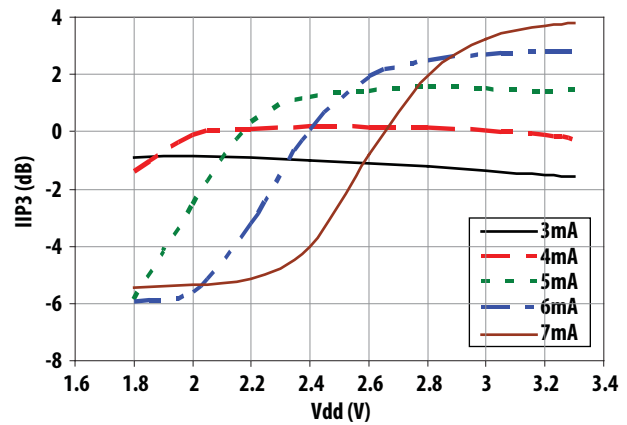

Figure 14. IIP3 vs Vdd vs Idd

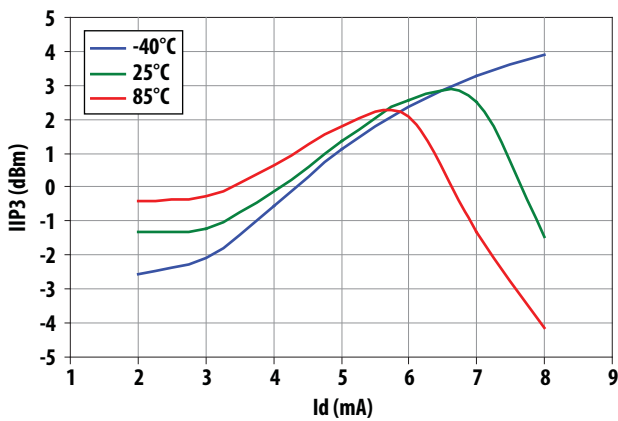

Figure 15. IIP3 vs Id vs Temp

**MGA-231T6 Typical Performance Curves at 25°C, R2 = 8.2Kohm, Vdd = 2.85V, Vsd = 1.8V (unless specified otherwise)**

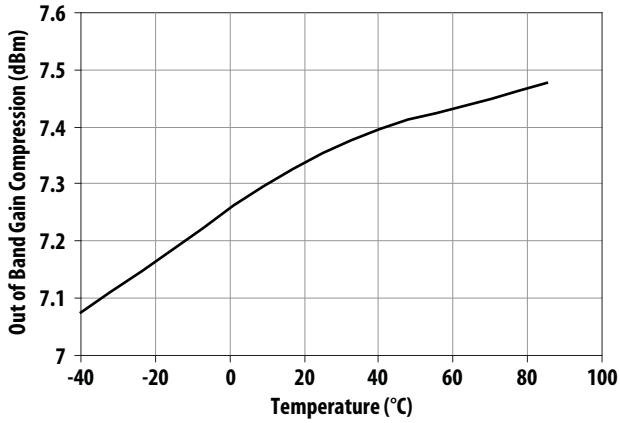

Figure 16. Input signal required at 890MHz interference signal to cause 1dB gain compression at 1.575GHz vs Temp

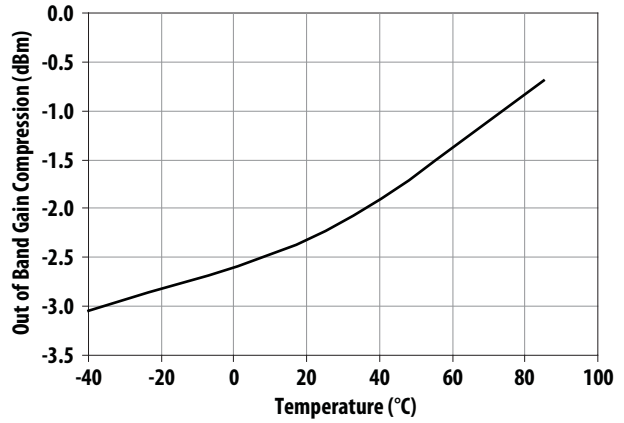

Figure 17. Input signal required at 1885MHz interference signal to cause 1dB gain compression at 1.575GHz vs Temp

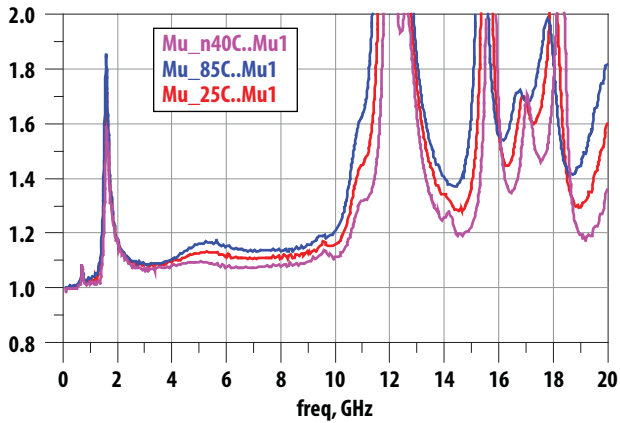

Figure 18. Edwards-Sinsky Output Stability Factor (Mu') vs Freq vs Temp

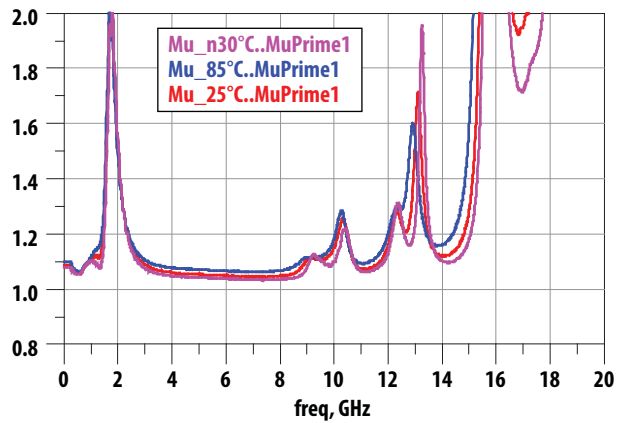

Figure 19. Edwards-Sinsky Input Stability Factor (Mu') vs Freq vs Temp



## MGA-231T6 Scattering Parameter Measurement Reference Planes

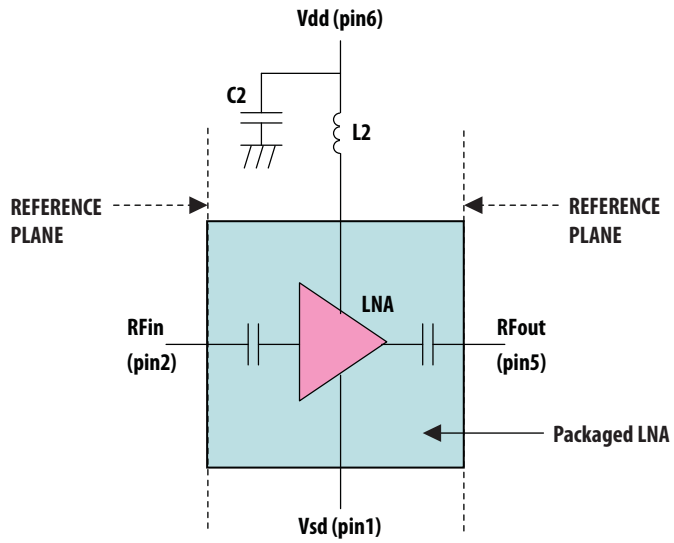

Figure 20. Scattering parameter measurement reference planes

## MGA-231T6 Scattering Parameter Measurement with Vdd = 2.85V, Idd = 4mA, L2 = 2.7nH, C2 = 47pF (Murata 0402)

The S-parameters measurement reference planes are described in Figure 20. The PCB is 10mils Rogers R04350.

Freq (GHz)	S11	S11	S21	S21	S12	S12	S22	S212
	Mag.	Ang.	Mag.	Ang.	Mag.	Ang.	Mag.	Ang.
0.5	0.9798	-9.89	0.0963	-36.96	0.0001	72.50	0.9905	-22.07
0.6	0.9768	-11.15	0.1766	-42.68	0.0001	105.74	0.9896	-27.89
0.7	0.9721	-12.97	0.2867	-46.41	0.0001	-105.96	0.9824	-33.24
0.8	0.9610	-14.87	0.4312	-52.26	0.0005	-96.68	0.9865	-38.66
0.825	0.9610	-15.29	0.4736	-53.91	0.0006	-99.26	0.9846	-40.24
0.9	0.9595	-16.65	0.6228	-59.12	0.0011	-106.29	0.9775	-45.14
1.0	0.9497	-18.59	0.8854	-66.84	0.0020	-112.56	0.9724	-52.47
1.1	0.9473	-20.44	1.2555	-76.14	0.0033	-118.68	0.9488	-61.90
1.2	0.9442	-22.51	1.8077	-87.97	0.0057	-127.32	0.9080	-74.64
1.3	0.9428	-25.02	2.6291	-104.60	0.0094	-140.81	0.8036	-94.23
1.4	0.9291	-28.19	3.7096	-129.38	0.0150	-162.71	0.5691	-128.90
1.5	0.8949	-31.20	4.4052	-162.49	0.0199	167.72	0.2613	143.17
1.575	0.8580	-32.12	4.2251	173.74	0.0206	144.86	0.3863	57.90
1.6	0.8509	-32.20	4.0805	167.08	0.0201	139.73	0.4571	43.57
1.7	0.8322	-32.42	3.4089	145.69	0.0178	121.96	0.6747	9.53
1.8	0.8192	-33.14	2.8216	131.20	0.0163	110.98	0.7861	-9.12
1.885	0.8117	-34.05	2.4718	122.85	0.0150	105.16	0.8270	-19.02
1.9	0.8111	-34.21	2.4326	121.83	0.0146	105.00	0.8299	-20.06
2.0	0.7983	-35.49	2.1754	112.43	0.0145	100.71	0.8839	-28.30
2.3	0.7656	-39.34	1.6197	92.63	0.0129	91.76	0.9307	-47.34
2.4	0.7505	-40.82	1.4963	87.10	0.0130	88.84	0.9392	-52.37
2.5	0.7406	-42.16	1.3963	82.55	0.0125	86.98	0.9352	-56.83
3.0	0.6912	-48.25	1.0547	59.18	0.0129	83.70	0.9457	-77.19
3.5	0.6528	-50.02	0.8340	40.67	0.0137	82.89	0.9577	-94.75
4.0	0.6212	-53.48	0.6803	23.01	0.0148	83.06	0.9514	-111.12
4.5	0.5904	-57.99	0.5660	5.64	0.0162	81.74	0.9504	-126.49
5.0	0.5626	-63.00	0.4713	-11.29	0.0180	82.40	0.9579	-141.84
6.0	0.5379	-73.85	0.3100	-44.48	0.0233	83.15	0.9519	-174.05
7.0	0.5274	-87.80	0.1785	-74.89	0.0313	77.85	0.9567	159.24
8.0	0.5802	-109.03	0.0871	-100.06	0.0292	60.47	0.9583	139.16
9.0	0.4642	-159.02	0.1084	-116.73	0.0774	-6.65	0.9273	119.66
10.0	0.3145	-125.14	0.1770	135.02	0.2135	91.76	0.8623	103.49
11.0	0.4577	-156.21	0.3001	69.20	0.3397	41.97	0.7179	81.58
12.0	0.3568	-141.87	0.1551	-21.83	0.1567	-64.81	0.8292	92.01
13.0	0.5951	176.57	0.1368	19.31	0.0913	25.82	0.9341	68.61
14.0	0.7567	150.52	0.2047	9.28	0.1740	14.51	0.9165	59.31
15.0	0.8813	136.71	0.2206	0.14	0.1940	8.93	0.9168	52.67
16.0	0.9091	113.12	0.2959	-17.28	0.2823	-12.29	0.8855	36.13
17.0	0.9285	90.82	0.3197	-37.74	0.3132	-35.24	0.8701	22.96
18.0	0.8777	72.48	0.3138	-55.71	0.3095	-55.02	0.8879	12.63
19.0	0.5801	42.49	0.3116	-80.45	0.3089	-81.70	0.8591	2.20
20.0	0.9040	50.05	0.3900	-72.66	0.3890	-75.30	0.8966	-5.51

**MGA-231T6 Scattering Parameter Measurement with Vdd = 1.8V, Idd = 4mA, L2 = 2.7nH, C2 = 47pF (Murata 0402)**

Freq (GHz)	S11	S11	S21	S21	S12	S12	S22	S212
	Mag.	Ang.	Mag.	Ang.	Mag.	Ang.	Mag.	Ang.
0.5	0.9825	-10.15	0.0906	-37.07	0.0001	86.13	0.9960	-21.99
0.6	0.9793	-11.47	0.1661	-43.04	0.0000	105.28	0.9923	-27.93
0.7	0.9765	-13.31	0.2704	-46.77	0.0002	-106.21	0.9896	-33.11
0.8	0.9663	-15.29	0.4063	-52.89	0.0007	-101.05	0.9904	-38.70
0.825	0.9665	-15.75	0.4463	-54.48	0.0008	-102.37	0.9877	-40.10
0.9	0.9648	-17.15	0.5876	-59.88	0.0014	-107.63	0.9830	-45.00
1.0	0.9565	-19.15	0.8336	-67.85	0.0024	-113.29	0.9745	-52.43
1.1	0.9558	-21.13	1.1806	-77.33	0.0041	-119.68	0.9487	-61.69
1.2	0.9526	-23.33	1.6903	-89.41	0.0069	-128.17	0.9027	-74.29
1.3	0.9524	-26.00	2.4390	-106.13	0.0112	-141.68	0.7914	-93.29
1.4	0.9391	-29.42	3.4006	-130.68	0.0176	-163.17	0.5493	-125.98
1.5	0.9028	-32.66	4.0160	-162.73	0.0232	168.35	0.2205	148.71
1.575	0.8646	-33.73	3.8833	174.11	0.0242	146.51	0.3438	55.97
1.6	0.8564	-33.84	3.7630	167.55	0.0237	141.31	0.4174	41.76
1.7	0.8349	-34.17	3.1833	146.24	0.0214	123.70	0.6451	8.79
1.8	0.8209	-34.87	2.6573	131.61	0.0197	112.37	0.7650	-9.46
1.885	0.8131	-35.85	2.3409	123.12	0.0183	106.92	0.8116	-19.18
1.9	0.8123	-36.02	2.3042	121.97	0.0179	106.42	0.8165	-20.30
2.0	0.8002	-37.32	2.0699	112.57	0.0177	101.62	0.8725	-28.41
2.3	0.7686	-41.43	1.5526	92.26	0.0158	91.80	0.9291	-47.46
2.4	0.7548	-42.99	1.4381	86.59	0.0160	88.74	0.9396	-52.50
2.5	0.7451	-44.42	1.3436	81.95	0.0153	87.03	0.9358	-56.93
3.0	0.6979	-50.99	1.0233	58.01	0.0160	82.57	0.9459	-77.14
3.5	0.6580	-53.48	0.8159	39.03	0.0168	80.94	0.9576	-94.78
4.0	0.6245	-57.81	0.6701	20.89	0.0182	79.81	0.9540	-111.28
4.5	0.5943	-63.28	0.5618	3.19	0.0199	78.00	0.9543	-126.53
5.0	0.5684	-69.23	0.4726	-14.19	0.0221	77.59	0.9607	-141.88
6.0	0.5415	-82.60	0.3162	-48.43	0.0284	75.74	0.9560	-174.16
7.0	0.5339	-100.27	0.1857	-80.08	0.0366	69.40	0.9595	159.04
8.0	0.5945	-125.24	0.0921	-106.89	0.0329	50.49	0.9613	139.04
9.0	0.5000	-3.84	0.1101	-120.20	0.0903	164.34	0.9294	119.46
10.0	0.2489	-146.57	0.1819	132.97	0.2441	81.85	0.8589	103.44
11.0	0.4126	1.84	0.2993	64.47	0.3721	30.62	0.7145	82.67
12.0	0.2770	-159.67	0.1565	-27.13	0.1713	-74.37	0.8323	91.53
13.0	0.5459	159.23	0.1300	13.95	0.0924	15.06	0.9377	68.53
14.0	0.6920	135.03	0.1960	3.18	0.1735	3.55	0.9183	59.36
15.0	0.8035	124.06	0.2092	-4.85	0.1888	-0.19	0.9206	52.63
16.0	0.8182	101.67	0.2785	-21.97	0.2692	-20.20	0.8893	36.32
17.0	0.8337	81.30	0.3034	-42.00	0.3002	-41.91	0.8757	22.99
18.0	0.8130	64.98	0.2975	-57.51	0.2945	-58.68	0.8962	12.50
19.0	0.5099	37.02	0.2882	-81.85	0.2870	-84.34	0.8667	2.04
20.0	0.8470	45.58	0.3755	-74.73	0.3752	-78.06	0.9026	-5.60

## Noise Parameters

The Noise parameters are measured using source pull method. Figure 20 shows the input and output reference planes. The PCB is 10mils Rogers R04350.

### MGA-231T6 Typical Noise Parameters

25°C, Freq = 1.575GHz, Vdd = 2.85V, Idd = 4mA

Freq (GHz)	Fmin (dB)	Gamma Opt		
		Mag.	Ang.	Rn/50
1	0.625	0.812	23.095	0.6268
1.575	0.67	0.785	33.77	0.5286
2	0.71	0.783	38.945	0.5296

25°C, Freq = 1.575GHz, Vdd = 2.85V, Idd = 8mA

Freq (GHz)	Fmin (dB)	Gamma Opt		
		Mag.	Ang.	Rn/50
1	0.585	0.8005	24.69	0.5597
1.575	0.655	0.775	34.98	0.4795
2	0.645	0.776	39.835	0.4683

## Package Dimensions

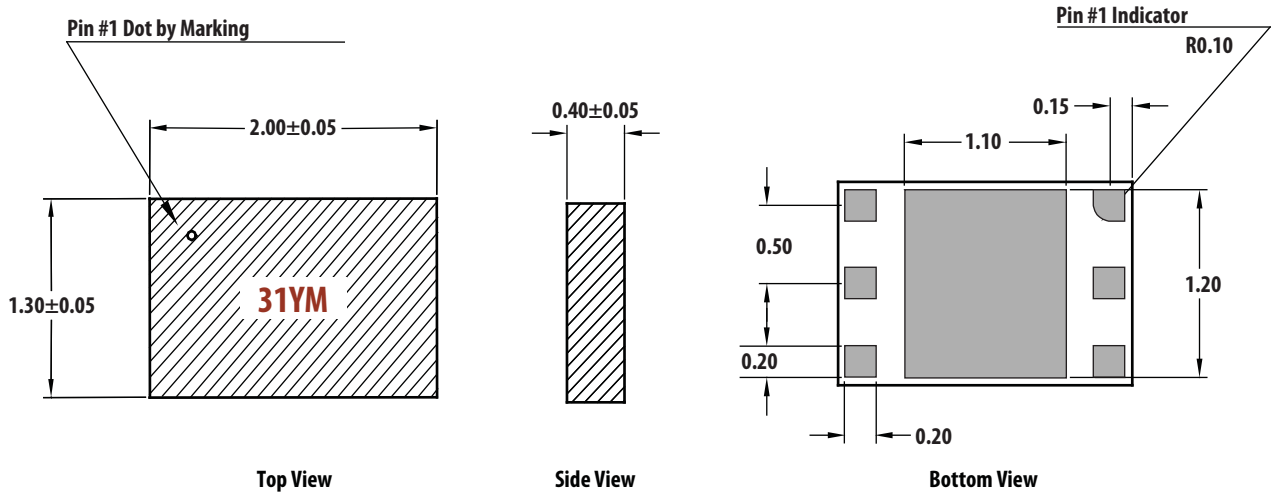

## Part Number Ordering Information

Part Number	No. of Devices	Container
MGA-231T6-BLKG	100	Antistatic bag
MGA-231T6-QC1	3000	7" Reel
MGA-231T6-TR1G	3000	7" Reel

## PCB Land Patterns

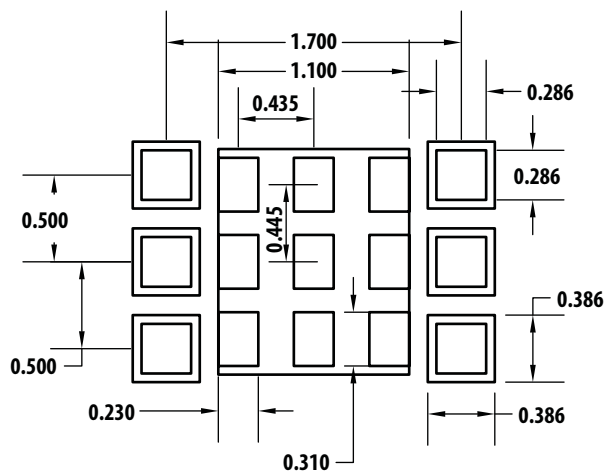

PCB Land Pattern Without Via  
(dimension in mm)

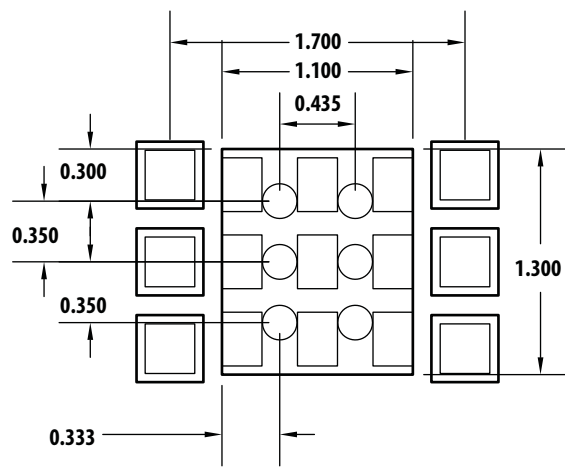

PCB Land Pattern With Via  
(dimension in mm)

## Stencil Outline and Combined PCB Land Patterns Stencil Layout

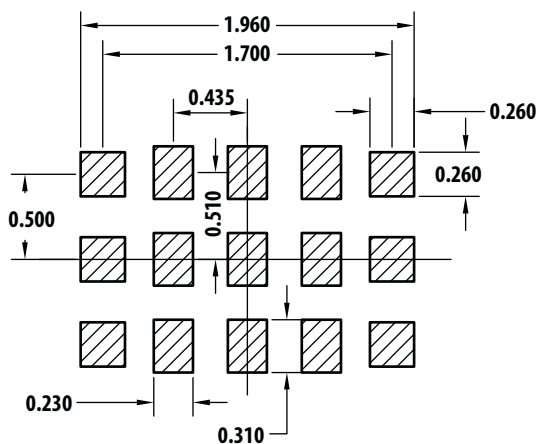

Stencil Outline Drawing  
(dimension in mm)

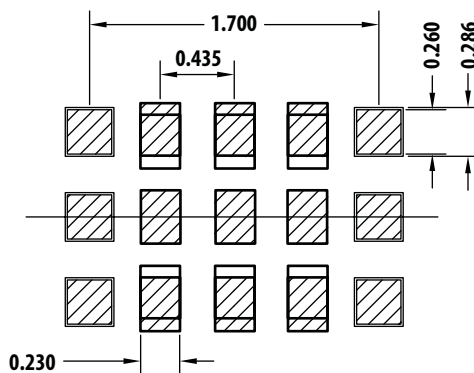

Combined Land Pattern & Stencil Layouts  
(dimensions in mm)

Note 1. Stencil thickness = 4 mils

## Device Orientation

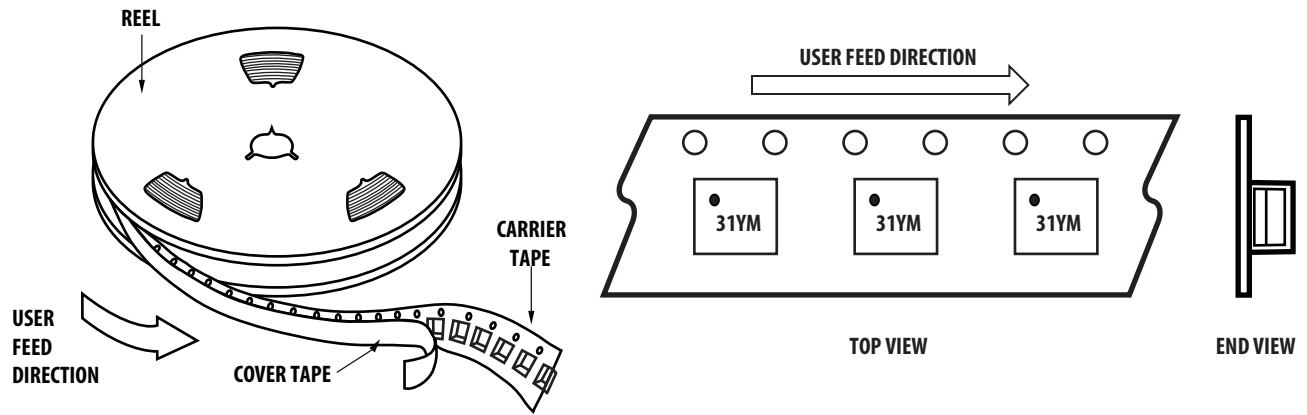

## Tape Dimensions

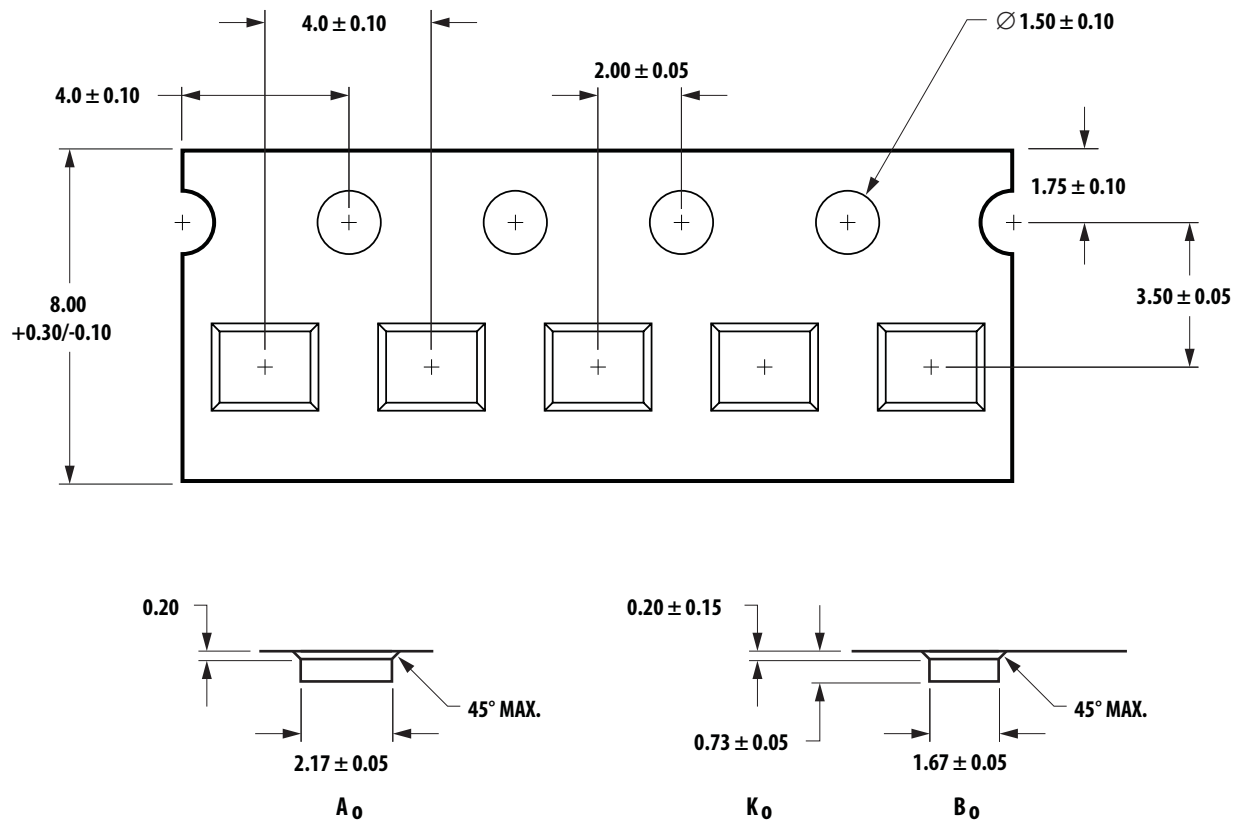

Dimensions are in millimeters

# Reel Dimensions (7 inch reel)

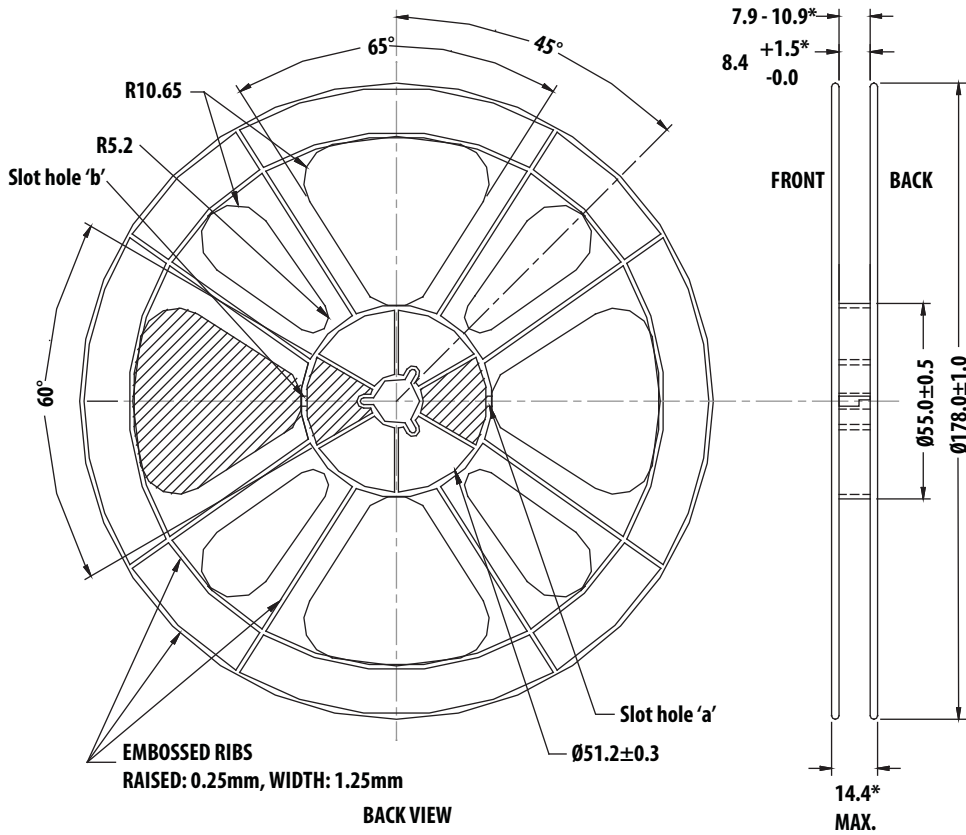
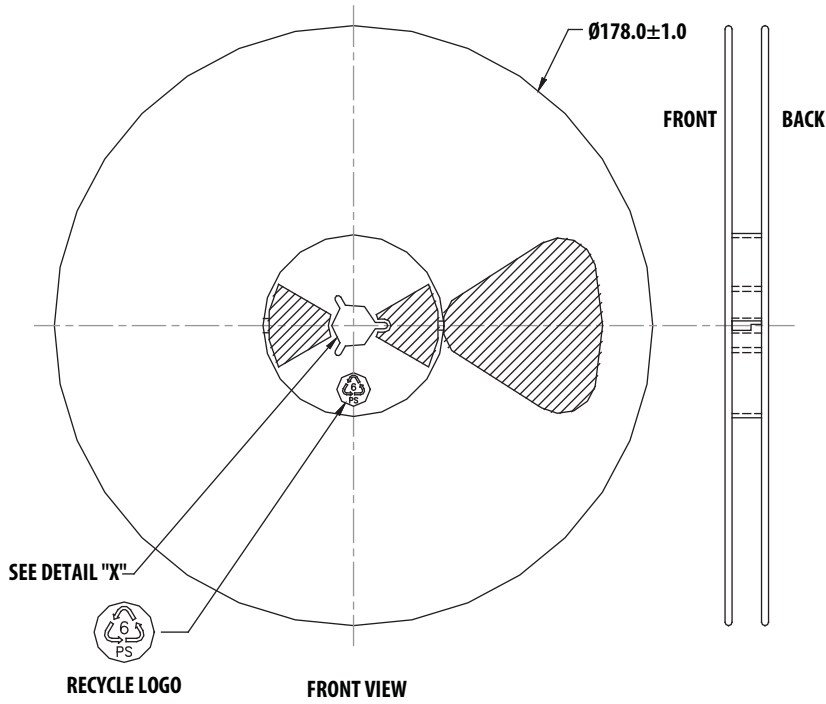

For product information and a complete list of distributors, please go to our web site: [www.avagotech.com](http://www.avagotech.com)

Avago, Avago Technologies, and the A logo are trademarks of Avago Technologies in the United States and other countries. Data subject to change. Copyright © 2005-2010 Avago Technologies. All rights reserved. AV02-2212EN - March 19, 2010

