

APPROVAL

PART NO.	DESCRIPTION	REMARKS
HT2201L	LCD MODULE (176 x RGB x 220 Dots)	This is ROHS compliant

CUSTOMER APPLICATION P/N	
APPROVED BY	
DATE	

PLEASE KINDLY FIND AND APPROVE THE SPECIFICATIONS INSERTED
HEREIN AND RETURN ONE COPY HERE OF WITH YOUR SIGNATURE OF APPROVAL.

PERPARED BY	CHECKED BY	CONFIRMED BY



HYES Optoelectronics, Inc.

2000 Wyatt Drive Suite 6
Santa Clara, CA 95054 USA

REVISION HISTORY

Date	Rev. No.	Page	Summary
Nov. 30, 2007	-	ALL	- 1'st Issue

CONTENTS

- 1. Basic Specifications**
 - 1.1 Display Specifications**
 - 1.2 Mechanical Specifications**
 - 1.3 Outline Dimension**
 - 1.4 Voltage Generation Circuit**
 - 1.5 Schematic**
- 2. Electrical Characteristics**
 - 2.1 Absolute Maximum Ratings**
 - 2.2 Environmental Conditions**
 - 2.3 DC Characteristics**
- 3. Optical Characteristics**
- 4. Interface Pins**
- 5. Backlight Specifications (LED Unit)**
- 6. Recommended Software Setting Values (Initial code)**
- 7. Power Supply Sequence & Instruction setting**
- 8. Read/Write Timing characteristics (80 series MPU)**
- 9. LCD Module Out-Going Quality Level**
- 10. The Caution and Handling**

Date : Nov. 30, 2007

TECHNICAL SPECIFICATION

HYES

LCM

HT2201L

Page 3 of 24

1. Basic Specifications

1.1 Display Specifications

Item	Description	Note
Resolution	176 × RGB × 220	
Display mode	TFT, Normally White, Transmissive	262K Color
Viewing direction	6 O'clock	
Driving method	528Ch-Source, 220Ch-Gate	
Backlighting	LED, White (4 chips in Serial)	
Diver IC	R61503U, COG	
Others	-	

1.2 Mechanical Specifications

Item	Specification	Unit
Module Size (W × H × T)	40.4 × 56.0 × 2.55	mm
Viewing Area (W × H)	-	mm
Active Area (W × H)	34.848 × 43.56	mm
Dot Size (W × H)	0.056 × 0.188	mm
Dot Pitch (W × H)	0.066 × 0.198	mm
Weight	-	g

Date : Nov. 30, 2007

TECHNICAL SPECIFICATION

HYES

LCM

HT2201L

Page 4 of 24

1.3 Outline Dimension

FPC CONNECTION

1	GND
2	XL
3	YD
4	XR
5	YU
6	GND
7	LCM_ID
8	VCC&VCL
9	IDVCC
10	NC
11	/CS
12	RS
13	/WR
14	/RD
15	DB00
16	DB01
17	DB02
18	DB03
19	DB04
20	DB05
21	DB06
22	DB07
23	DB08
24	DB09
25	DB10
26	DB11
27	DB12
28	DB13
29	DB14
30	DB15
31	DB16
32	DB17
33	/RESET
34	IM3
35	IMO
36	LEDA
37	LEDK
38	GND

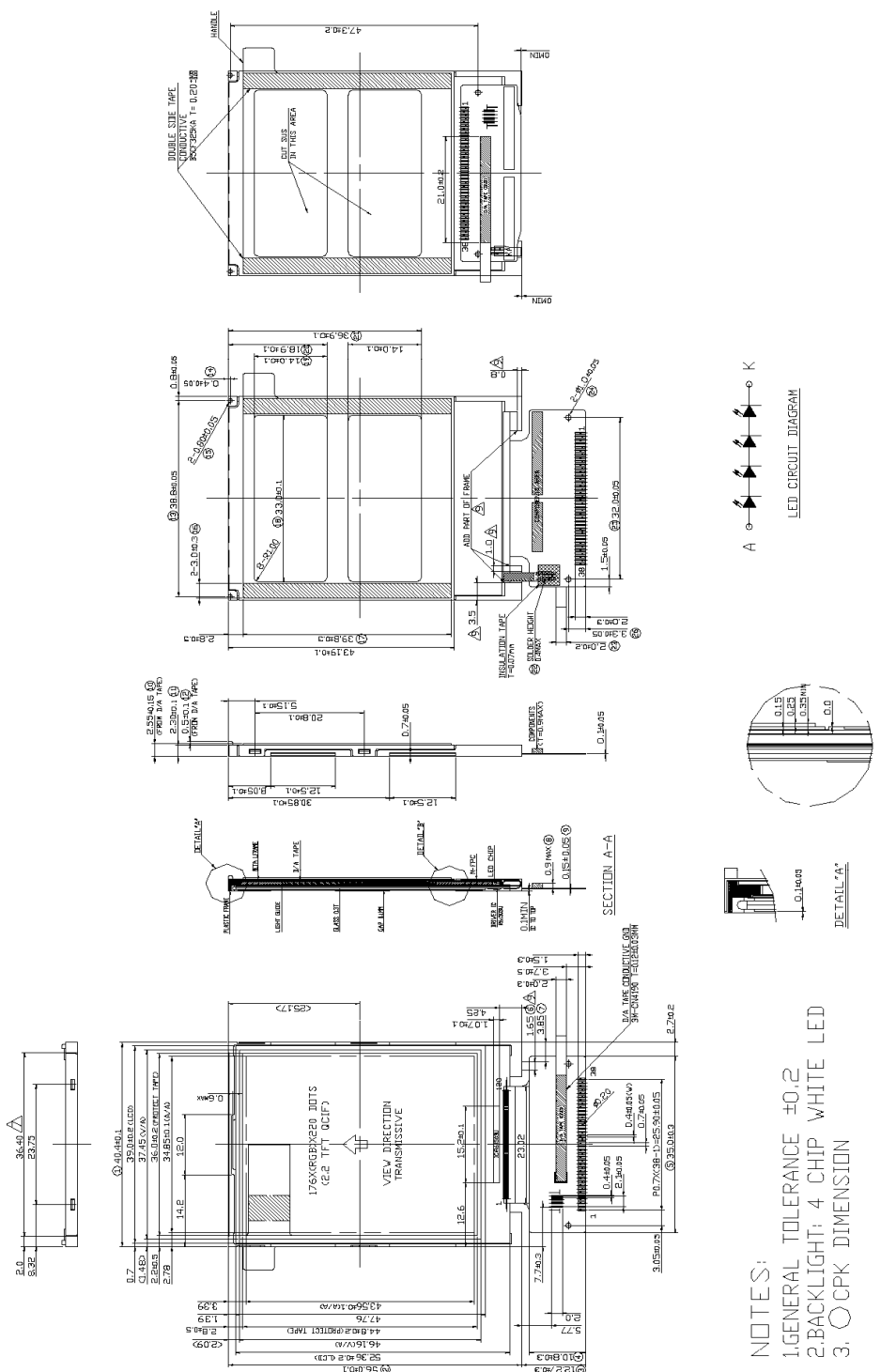

NOTES:
 1.GENERAL TOLERANCE ± 0.2
 2.BACKLIGHT: 4 CHIP WHITE LED
 3. \varnothing CPK DIMENSION

Date : Nov. 30, 2007

TECHNICAL SPECIFICATION



LCM

HT2201L

Page 5 of 24

1.4 Block Diagram

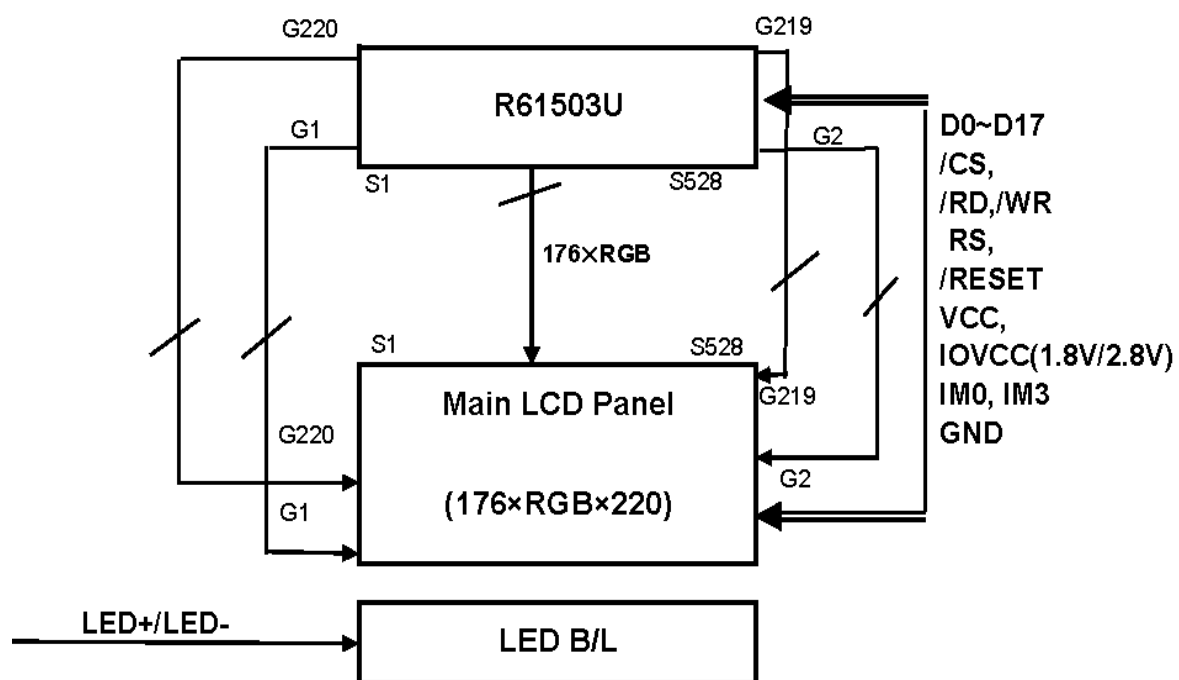

IM3	IM0	Interface	Datebus
0	0	16-bit interface	DB17-DB10, DB8-DB1
0	1	8-bit interface	DB17-DB10
1	0	18-bit interface	DB17-DB0
1	1	9-bit interface	DB17-DB9

Date : Nov. 30, 2007

TECHNICAL SPECIFICATION

HYES

LCM

HT2201L

Page 6 of 24

1.5 Schematic

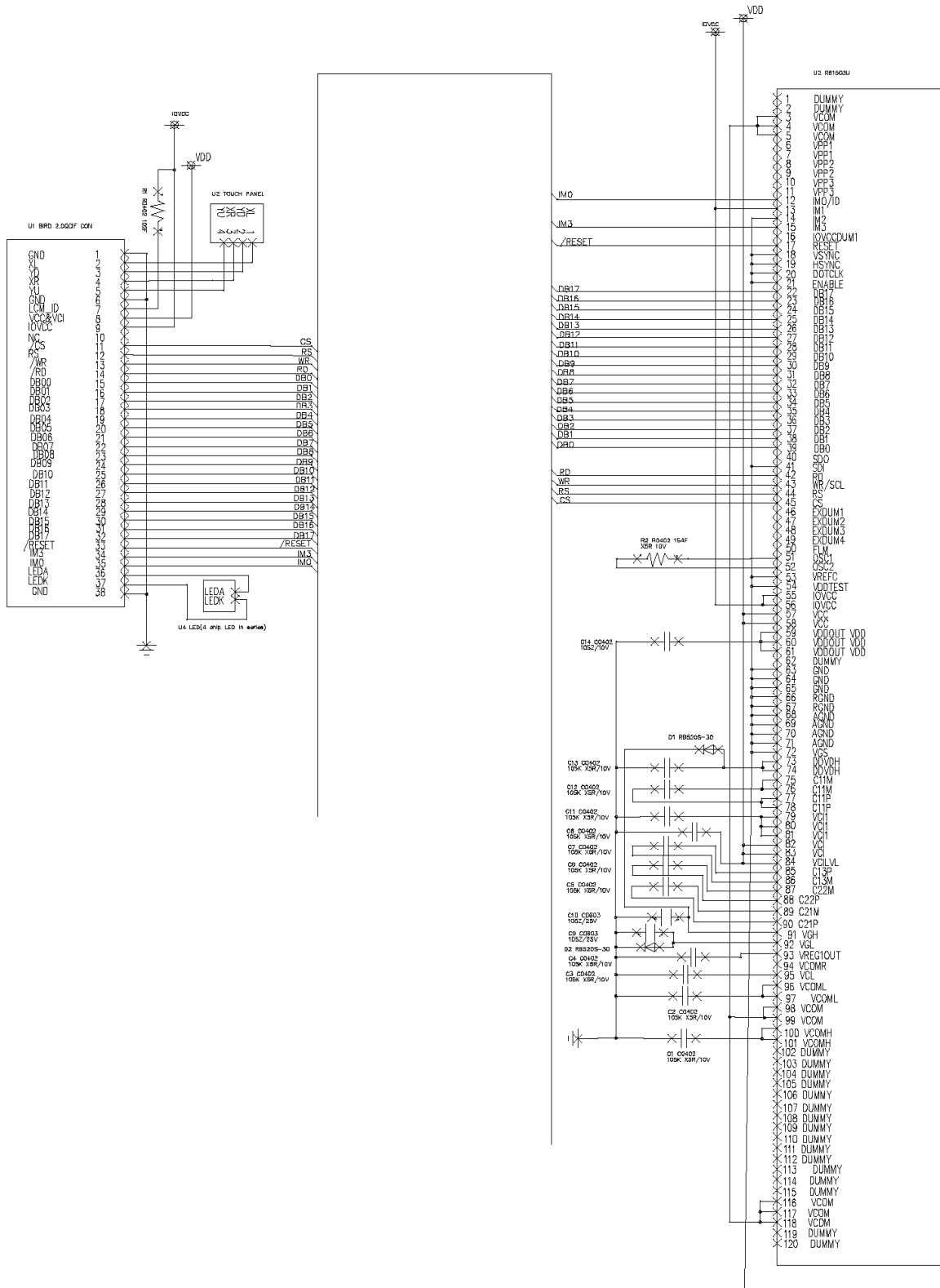

Date : Nov. 30, 2007

TECHNICAL SPECIFICATION



LCM

HT2201L

Page 7 of 24

2. Electrical Characteristics

2.1 Absolute Maximum Ratings

Item	Symbol	Value			Unit	Condition	Remark
		Min.	Typ.	Max			
Supply Voltage	Logic	V _{CC}	- 0.3	-	4.6	V	Ta =25℃
	LCD	VGH-VGL	-0.3	-	30	V	Ta =25℃
Input Voltage	V _{IN}	-0.3	-	VCC + 0.3	V	Ta =25℃	

2-2 Environmental Conditions

Item	Symbol	Min.	Max.	Unit
Operating temperature	Topr	-30	70	℃
Storage temperature	Tstg	-40	80	℃
Humidity (Ambient temperature=Ta)	Ta ≤ 50℃		95% RH max.	

2-3 DC Characteristics

Items	Sysbol	Spec. Value			Unit	Condition	
		Min.	Typ.	Max.			
Operating voltage	Logic	VCC	2.72	2.8	2.88	V	
			1.72	1.8	1.88	V	
	Vgate	VGH - VGL	-	22.0	-	V	Note 1)
Supply current	ICC	-	2.0	4.0	mA	Note 2)	
		-	2.0	4.2	mA	Note 3)	
Input voltage	High level	V _{IH}	0.8 × IOV _{CC}	-	IOV _{CC}	V	-
	Low level	V _{IL}	-0.3	-	0.2 × V _{CC}	V	-

Note 1) The value can adjusted by software to optimize display quality

Note 2) Display White

Note 3) Display Black

Date : Nov. 30, 2007

TECHNICAL SPECIFICATION

HYES

LCM

HT2201L

Page 8 of 24

3. Optical Characteristics

Transmissive mode

(Ta = 25°C)

Item	Symbol		Min.	Typ.	Max.	Unit	Condition	Note
Viewing	θ2-θ1	∅=0 (Y1-Y2)	50	60	-	Deg	Cr > 10	
		∅=90 (X1-X2)	80	90	-			
Contrast ratio	Cr		200	300	-	-	θ = 0 ∅ = 0	
Response Time	Tr + Tf		-	25	40	ms	θ = 0 ∅ = 0	
CIE Coordi- -nate	R	(x,y)	0.52, 0.28	0.57, 0.33	0.62, 0.38		θ = 0 ∅ = 0	
	G	(x,y)	0.29, 0.56	0.34, 0.61	0.39, 0.66			
	B	(x,y)	0.10, 0.05	0.15, 0.10	0.20, 0.15			
	W	(x,y)	0.24, 0.26	0.28, 0.31	0.34, 0.36			
Brightness	L		200	240	-	cd/m ²	ILED=18mA	
Uniformity			70	-	-			

* ∅ = 0°, ∅ = 90° means viewing direction.

* B/L is turned on.

* Remark : as for contrast ratio, it is measured in panel only.

Date : Nov. 30, 2007

TECHNICAL SPECIFICATION

HYES

LCM

HT2201L

Page 9 of 24

Note 1 . Definition of angle Θ and Φ

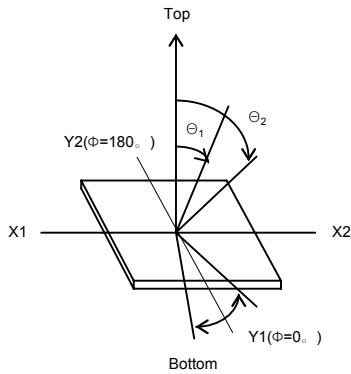

Note 2. Definition of viewing angle Θ_1 and Θ_2

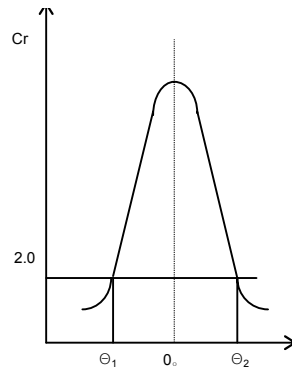

Note 3. Definition of contrast Cr

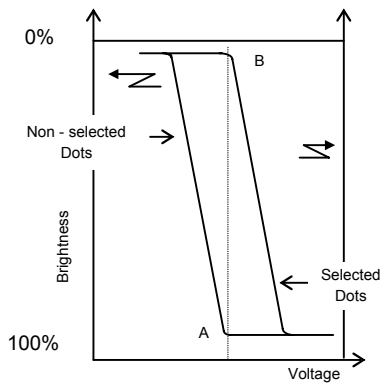

$Cr = (A/B)^P$ Negative : P = -1 Set Point
Positive : P = +1

Lens $\varnothing = 3\text{mm}$

Note 4. Definition of Optical response

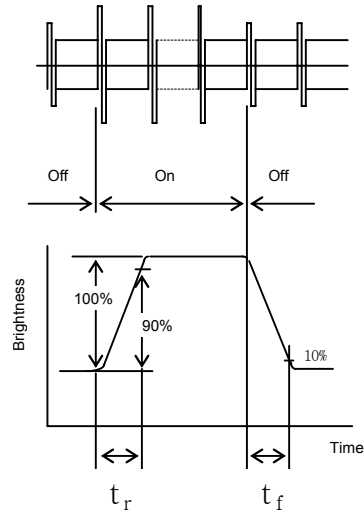

Note 5. Measuring Point(9 POINTS) (WxH)

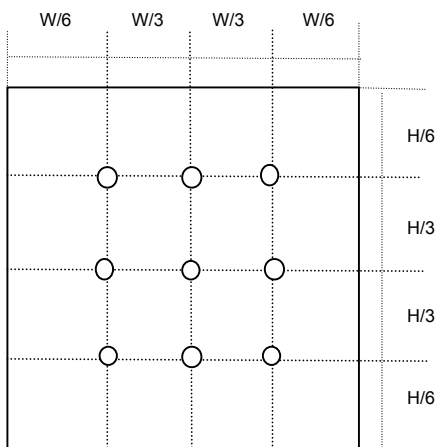

Rating is defined as the average brightness inside the viewing area

Date : Nov. 30, 2007

TECHNICAL SPECIFICATION



LCM

HT2201L

Page 10 of 24

4. Interface Pins

no	symbol	Description
1	GND	GND
2	XL	NC
3	YD	NC
4	XR	NC
5	YU	NC
6	GND	GND
7	LCM_ID	Connect 1k resistor with IOVCC(1.8V/2.8V)
8	VCC&VCI	VCC(2.8V)
9	IOVCC	IOVCC(1.8V/2.8V)
10	NC	NC
11	/CS	Chip select signal(low active)
12	RS	RS Signal (RS=0 : Contro,RS=1 : data)
13	/WR	Write Signal (low active)
14	/RD	Read Signal(low active)
15	DB0	Data Bit0
16	DB1	Data Bit1
17	DB2	Data Bit2
18	DB3	Data Bit3
19	DB4	Data Bit4
20	DB5	Data Bit5
21	DB6	Data Bit6
22	DB7	Data Bit7
23	DB8	Data Bit8
24	DB9	Data Bit9
25	DB10	Data Bit10
26	DB11	Data Bit11
27	DB12	Data Bit12
28	DB13	Data Bit13
29	DB14	Data Bit14
30	DB15	Data Bit15
31	DB16	Data Bit16
32	DB17	Data Bit17
33	/RESET	RESET signal(low active)
34	IM3	system interface control
35	IM0	system interface control
36	LEDA	LED Anode
37	LEDK	LED Cathode
38	GND	GND

Date : Nov. 30, 2007

TECHNICAL SPECIFICATION

HYES

LCM

HT2201L

Page 11 of 24

5. Backlight Specification (LED Unit)

Item	Symbol	Spec. Value			Unit	Condition
		Min.	Typ.	Max.		
Real Current	I_{LED}	-	18	20	mA	note 1.
Power dissipation	P_D	-	-	350	mW	note 2.
Operation temp.	Topr	- 30 ~ 70			°C	-
Storage temp.	Tstr	- 40 ~ 80			°C	-

Note 1. B/L: 4EA LED in Serial, the typical current is 18mA(full brightness)

Note2. Total power consumption(max) depends on LED current/ LED driver efficiency, etc.

6. Recommended Software Setting Values (Initial code)

LDI : R61503U

Initial code	
0000	0000
0000	0000
0000	0000
0000	0000
0000	0001
Power supply on sequence	
0007	0001 (DALAY 20)ms
0018	0001 (DALAY 20)ms
0010	17B0
0011	0000
0012	0117
0013	84B6
0012	0137 (DALAY 20)ms
Gamma setting	
0030	0003
0031	0204
0032	0002
0033	0207
0034	0507
0035	0303
0036	0407
0037	0702
0038	1702
0039	010f
003A	0001
other mode setting	
0001	0100
0002	0400
0003	1030
0004	0000
0008	0202
0009	0111
000C	0000
000E	0000
000F	0000
0014	0000
0020	0000
0021	0000
0070	1B00
0071	0001
007A	0000
0090	0000
0091	0100
0092	0007
0098	0001
0099	030C
009A	030C
009C	0000
009D	0000
Display on sequence	
0007	0001 (DALAY 20)ms
0007	0021 (DALAY 20)ms
0012	1137
0007	0233
0022	

Set standby mode

Display off sequence	
0007	0202
0012	0137(DALAY 50ms)
0007	0200
Power supply off sequence	
0010	0780
0011	0060
0012	0127
0013	04B6(DALAY 50ms)
0010	0700
Standby set	
0010	0701

Exit standby mode

0000	0001(DALAY 50ms)
0010	17B0
Power supply on sequence	
Display on sequence	

Partial display

0080	0020(1st display area)
0081	0020(1st display area)
0082	0030(1st display area)
0083	0060(2st display area)
0084	0060(2st display area)
0085	0090(2st display area)
Partial display on	
0007	3033
Partial display off	
0007	0233

NOTE: HYES requires the customer to follow the above instructions strictly. If customer would like to change the above instructions, the customer should inform HYES and get re-check from HYES, or the customer will be responsible for any unexpected result because of the change.

Date : Nov. 30, 2007

TECHNICAL SPECIFICATION

HYES

LCM

HT2201L

Page 13 of 24

7. Power Supply Sequence & Instruction setting

7.1 Power Supply Sequence

Power ON sequence

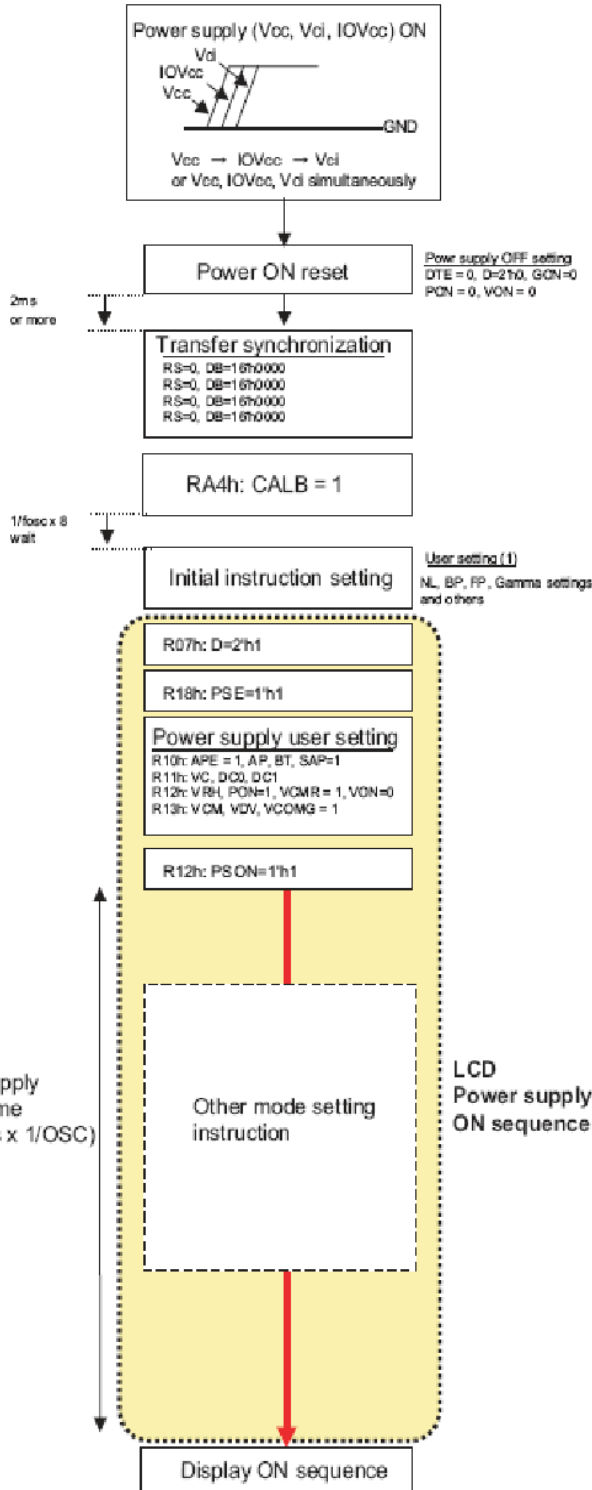

Power supply OFF sequence

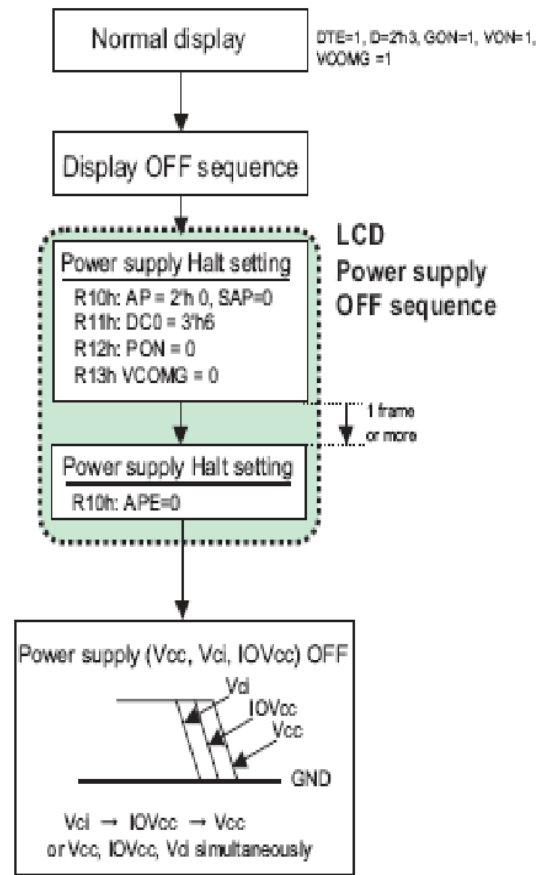

Date : Nov. 30, 2007

TECHNICAL SPECIFICATION

HYES

LCM

HT2201L

Page 14 of 24

7.2 Instruction setting Sequence

Display ON sequence

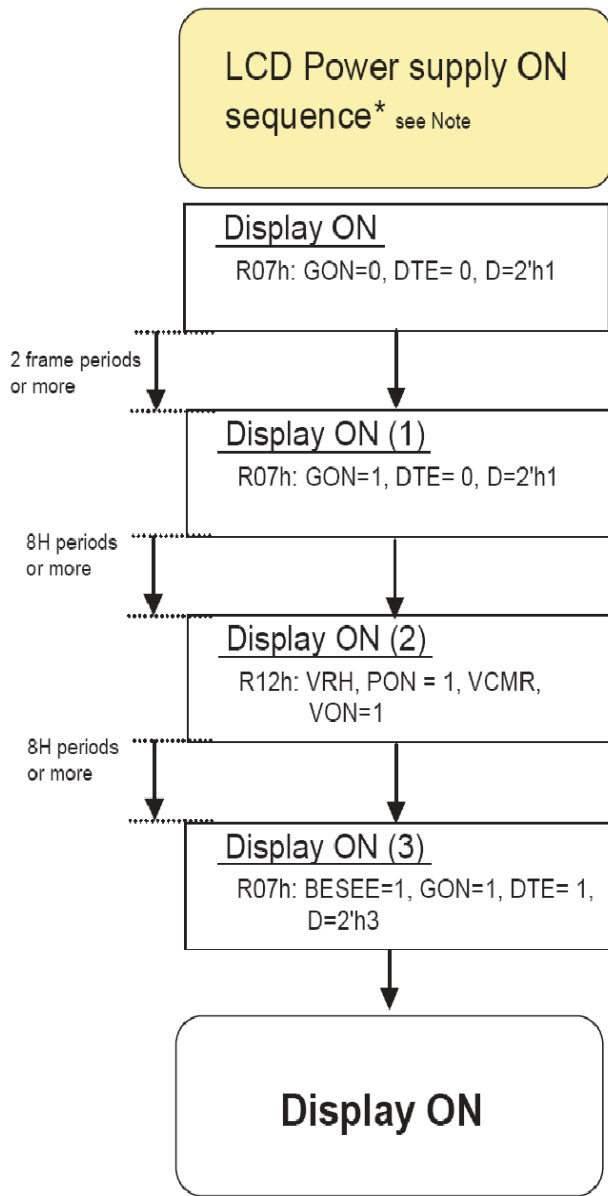

Note: See power supply setting sequenc

Display OFF sequence

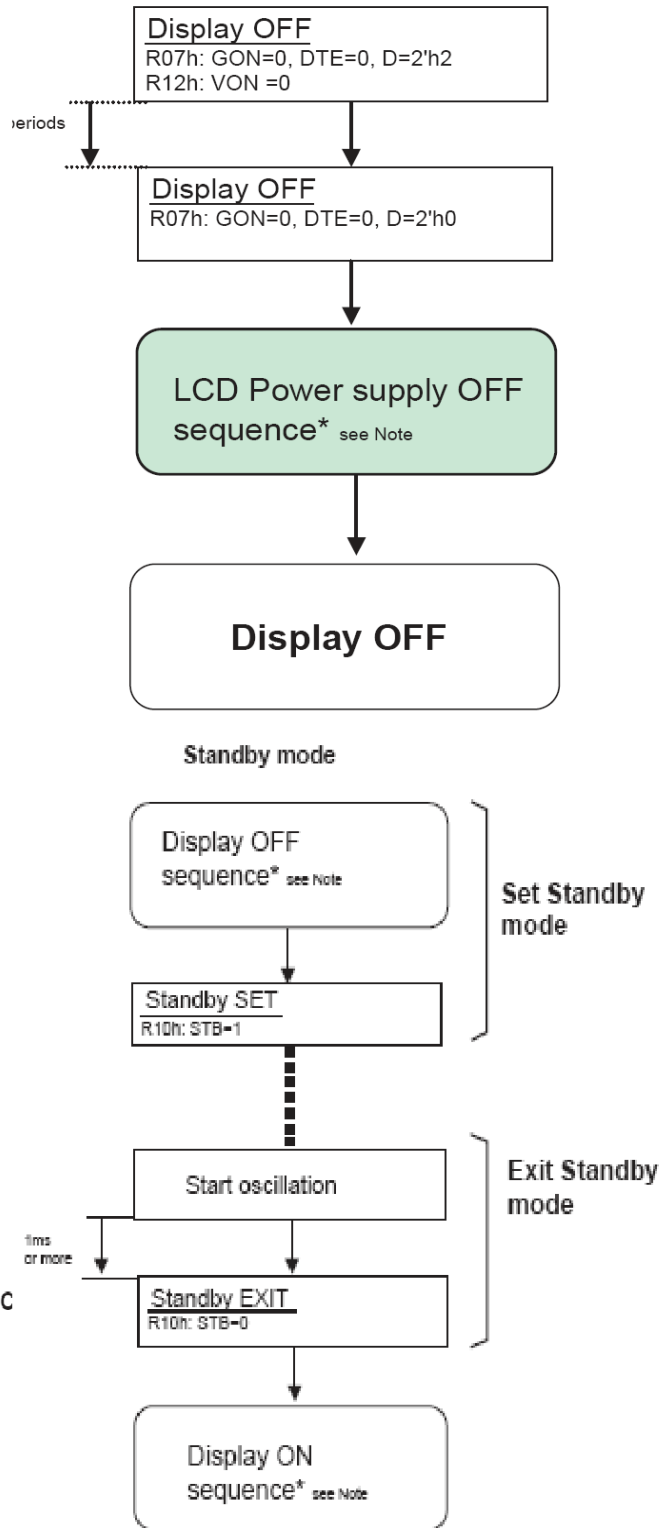

8. Read/Write Timing characteristics (80 series MPU)

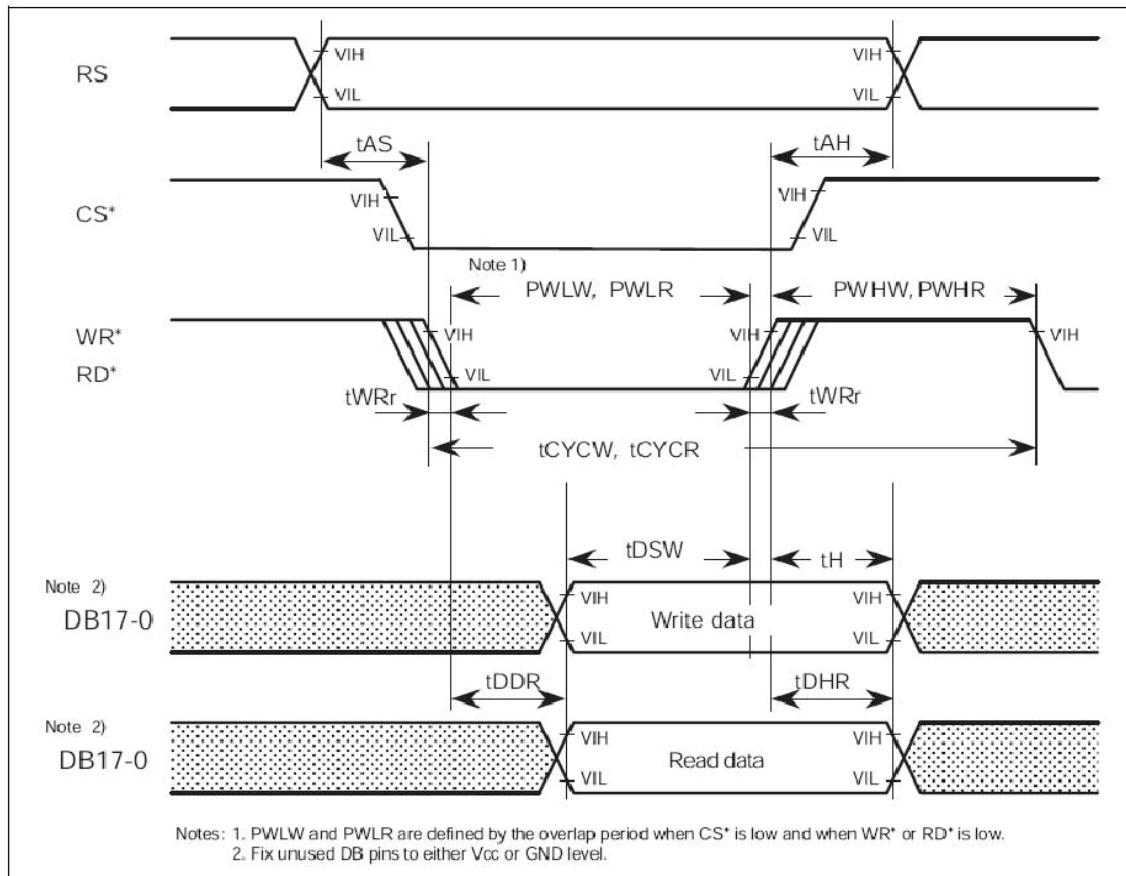

Table 86 Normal write operation (HWM= "0"), IOV_{CC} = 1.65V ~ 3.6V, V_{CC} = 2.5V ~ 3.6V

Item		Symbol	Unit	Timing diagram	Min	Typ	Max
Bus cycle time	Write	t _{CYCW}	ns	Figure 89	120	—	—
	Read	t _{CYCR}	ns	Figure 89	400	—	—
Write low-level pulse width		PW _{LW}	ns	Figure 89	40	—	—
Read low-level pulse width		PW _{LR}	ns	Figure 89	200	—	—
Write high-level pulse width		PW _{HW}	ns	Figure 89	50	—	—
Read high-level pulse width		PW _{HR}	ns	Figure 89	200	—	—
Write/Read rise/fall time		t _{WRr, WRr}	ns	Figure 89	—	—	25
Setup time	Write (RS~CS*, WR*)	t _{AS}	ns	Figure 89	0	—	—
	Read (RS~CS*, RD*)				10	—	—
Address hold time		t _{AH}	ns	Figure 89	2	—	—
Write data setup time		t _{DSW}	ns	Figure 89	25	—	—
Write data hold time		t _H	ns	Figure 89	5	—	—
Read data delay time		t _{DDR}	ns	Figure 89	—	—	100
Read data hold time		t _{DHR}	ns	Figure 89	5	—	—

Date : Nov. 30, 2007

TECHNICAL SPECIFICATION

HYES

LCM

HT2201L

Page 16 of 24

Reset Timing characteristics

Reset Operation

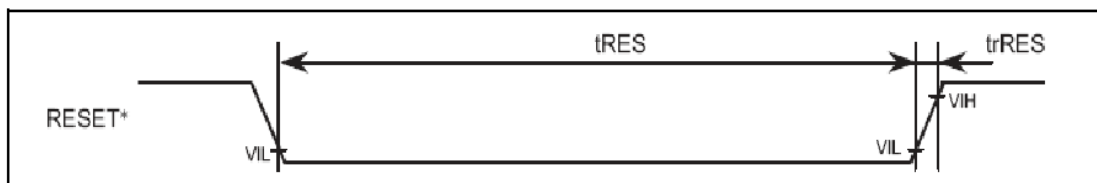

Item	Symbol	Unit	Timing diagram	Min	Typ	Max
Reset low-level width	t_{RES}	ms	Figure 91	1	—	—
Reset rise time	t_{rRES}	μ s	Figure 91	—	—	10

9. LCD Module Out-Going Quality Level

(1.0) Purpose

The LCD specification provides outgoing provision and its expected quality level based on our outgoing inspection of LCD.

(2.0) Applicable Scope

The LCD specification is applicable to the arrangement in regard to outgoing inspection and quality assurance after it.

(3.0) Quality Specification

(3.1) Quality Level

The quality level of HYES are based on MIL-STD-105D, Apply Level II, normal inspection by single sampling.

Rank	Item	AQL	Note
Major(MA)	Segment Short, Missing	0.4	
	Solder Bridging, Cold Solder		
	Outside Dimension		
Minor (MI)	Black Spots, White Spots, Foreign Substance, Pinhole, Segment Deformation, Scratches(Glass & Pol.) Air Bubbles between Glass & Polarizer, Color Variation, Solder Ball, Misalignment	1.0	

Note) AQL- Acceptable Quality Level

(3.2) Appearance Standards

1) Inspection Conditions

The LCD shall be inspected under 20W white fluorescent lamp light.

The distance between the eyes and the sample shall be 30cm.

All directions for inspecting the sample should be within 30° to perpendicular line.

2) Definition of the Area

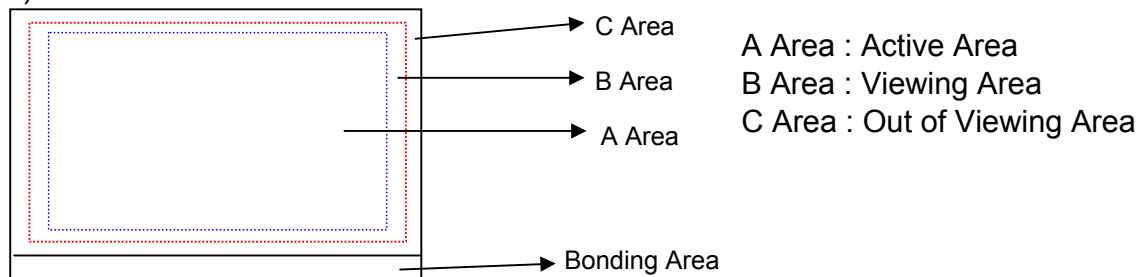

Date : Nov. 30, 2007

TECHNICAL SPECIFICATION

HYES

LCM

HT2201L

Page 18 of 24

(3.3) Apperance Spec

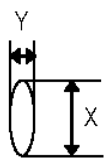
No	Item	Criteria	Rank	Remark																																																	
1	Segment Short Segment Missing	Not allowed	MA																																																		
2	Solder Bridging	Any bridging between components, except common circiut, is not allowed.	MA																																																		
3	Outside Dimension	Drawing & specification must be within permitable tolerance.	MA																																																		
4	Cold Solder	Cold solder is not allowed.	MA																																																		
5	Black(White) Spots, Foreign Substances (distance between allowable defects should more than 5mm)	<p>1) Round Type</p> <table border="1"> <thead> <tr> <th rowspan="2">Area Dimension**</th> <th colspan="2">Acceptable Q'ty</th> <th rowspan="2">Remark</th> </tr> <tr> <th>A Area</th> <th>B Area</th> </tr> </thead> <tbody> <tr> <td>$d \leq 0.1$</td> <td colspan="2">Ignore</td> <td></td> </tr> <tr> <td>$0.1 < d \leq 0.15$</td> <td colspan="2">2</td> <td></td> </tr> <tr> <td>$0.15 < d \leq 0.2$</td> <td colspan="2">1</td> <td></td> </tr> <tr> <td>$d > 0.2$</td> <td colspan="2">0</td> <td></td> </tr> </tbody> </table> <p>2) Liner Type</p> <table border="1"> <thead> <tr> <th rowspan="2">Lengt</th> <th rowspan="2">Width</th> <th colspan="2">Acceptable Q'ty</th> <th rowspan="2">Remark</th> </tr> <tr> <th>A Area</th> <th>B Area</th> </tr> </thead> <tbody> <tr> <td>-</td> <td>$W \leq 0.02$</td> <td colspan="2">Ignore</td> <td></td> </tr> <tr> <td>$L \leq 2$</td> <td>$0.2 < W \leq 0.03$</td> <td colspan="2">2</td> <td></td> </tr> <tr> <td>$L > 1$</td> <td>$0.3 < W \leq 0.05$</td> <td colspan="2">0</td> <td></td> </tr> <tr> <td></td> <td>$0.05 < W$</td> <td colspan="2">spot</td> <td></td> </tr> </tbody> </table> <p>At (1) & (2) total defect q'ty is must not exceed 5 pieces.</p>	Area Dimension**	Acceptable Q'ty		Remark	A Area	B Area	$d \leq 0.1$	Ignore			$0.1 < d \leq 0.15$	2			$0.15 < d \leq 0.2$	1			$d > 0.2$	0			Lengt	Width	Acceptable Q'ty		Remark	A Area	B Area	-	$W \leq 0.02$	Ignore			$L \leq 2$	$0.2 < W \leq 0.03$	2			$L > 1$	$0.3 < W \leq 0.05$	0				$0.05 < W$	spot			MI	 <p>** : Mean Diameter (X + Y)/2</p>
Area Dimension**	Acceptable Q'ty			Remark																																																	
	A Area	B Area																																																			
$d \leq 0.1$	Ignore																																																				
$0.1 < d \leq 0.15$	2																																																				
$0.15 < d \leq 0.2$	1																																																				
$d > 0.2$	0																																																				
Lengt	Width	Acceptable Q'ty		Remark																																																	
		A Area	B Area																																																		
-	$W \leq 0.02$	Ignore																																																			
$L \leq 2$	$0.2 < W \leq 0.03$	2																																																			
$L > 1$	$0.3 < W \leq 0.05$	0																																																			
	$0.05 < W$	spot																																																			
		<table border="1"> <thead> <tr> <th rowspan="2">Area Dimension**</th> <th colspan="2">Acceptable Q'ty</th> <th rowspan="2">Remark</th> </tr> <tr> <th>A Area</th> <th>B Area</th> </tr> </thead> <tbody> <tr> <td>$d \leq 0.1$</td> <td colspan="2">Ignore</td> <td></td> </tr> <tr> <td>$0.1 < d \leq 0.15$</td> <td colspan="2">2</td> <td></td> </tr> <tr> <td>$0.15 < d \leq 0.2$</td> <td colspan="2">1</td> <td></td> </tr> <tr> <td>$d > 0.2$</td> <td colspan="2">0</td> <td></td> </tr> </tbody> </table>	Area Dimension**	Acceptable Q'ty		Remark	A Area	B Area	$d \leq 0.1$	Ignore			$0.1 < d \leq 0.15$	2			$0.15 < d \leq 0.2$	1			$d > 0.2$	0																															
Area Dimension**	Acceptable Q'ty			Remark																																																	
	A Area	B Area																																																			
$d \leq 0.1$	Ignore																																																				
$0.1 < d \leq 0.15$	2																																																				
$0.15 < d \leq 0.2$	1																																																				
$d > 0.2$	0																																																				
7	Air Bubles Between Glass & Polarizer (Polarizer Defects)	<table border="1"> <thead> <tr> <th rowspan="2">Area Dimension**</th> <th colspan="2">Acceptable Q'ty</th> <th rowspan="2">Remark</th> </tr> <tr> <th>A Area</th> <th>B Area</th> </tr> </thead> <tbody> <tr> <td>$d \leq 0.3$</td> <td colspan="2">Ignore</td> <td></td> </tr> <tr> <td>$0.3 < d \leq 1.0$</td> <td colspan="2">1</td> <td></td> </tr> <tr> <td>$d > 1.0$</td> <td colspan="2">0</td> <td></td> </tr> </tbody> </table>	Area Dimension**	Acceptable Q'ty		Remark	A Area	B Area	$d \leq 0.3$	Ignore			$0.3 < d \leq 1.0$	1			$d > 1.0$	0			MI																																
Area Dimension**	Acceptable Q'ty			Remark																																																	
	A Area	B Area																																																			
$d \leq 0.3$	Ignore																																																				
$0.3 < d \leq 1.0$	1																																																				
$d > 1.0$	0																																																				

Date : Nov. 30, 2007

TECHNICAL SPECIFICATION

HYES

LCM

HT2201L

Page 19 of 24

(3.3) Appearance Spec

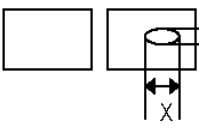
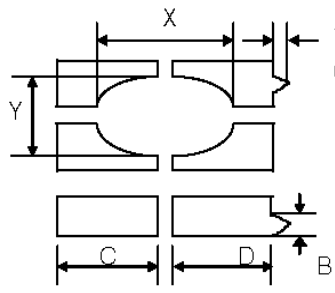
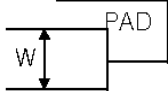
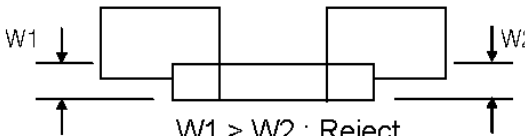
No	Item	Criteria	Rank	Remark								
8	Pinhole (On Segment)	 <p> $(X+Y)/2 \leq 0.2\text{mm}$ Within 1 per one segment (Less than 0.1mm is not counted) Total defects q'ty is must not exceed 5 pieces. </p>	MI									
9	Segment Deformation	 <p> $(X+Y)/2 \leq 0.2\text{mm}$ $A \leq 0.2\text{mm}$ $B \leq 0.2\text{mm}$ $(C-D) \leq 0.2\text{mm}$ </p> <table border="1" data-bbox="534 862 1141 1008"> <thead> <tr> <th></th> <th>Acceptable Q'ty</th> </tr> </thead> <tbody> <tr> <td>Dot, Segment</td> <td>1</td> </tr> <tr> <td>LCD</td> <td>5</td> </tr> <tr> <td>≤ 0.1</td> <td>Ignore all defect</td> </tr> </tbody> </table> <p>Each visible dot must be more than half effective dot area</p>		Acceptable Q'ty	Dot, Segment	1	LCD	5	≤ 0.1	Ignore all defect	MI	$(X + Y)/2 \leq 0.2\text{mm}$
	Acceptable Q'ty											
Dot, Segment	1											
LCD	5											
≤ 0.1	Ignore all defect											
10	Color Variation	Within the three colors, except LCD Standard color is acceptable.	MI									
11	Glass & Polarizer Scratch	Follow NO.5(2) condition	MI									
12	Solder Ball	1)Acceptable if the size of void is less 2)Acceptable if a solder ball is not movable 3)Rejectable if the solder ball exceed 5EA in 2.54 × 2.54mm area.	MI									
13	Miss Alignment	1)Acceptable if it dose not exceed 50% of the lead width IC.  <p> $X \leq W/2$: Accept $X > W/2$: Reject </p> <p>IC LEAD</p> 2)Rejectable, provided that it does exceed 50% of the component termination width.  <p> $W1 > W2$: Reject </p>										

Note : A limitation sample is given top priority

Date : Nov. 30, 2007

TECHNICAL SPECIFICATION

HYES

LCM

HT2201L

Page 20 of 24

(4.0) Reliability Condition

Item	Content
Room Temperature Operation	50,000 hrs

Not to be conspicuous fall of LCD panel Functions, Ability and Appearance after after following test.

(4.1) Reliability Test - Module Middle Reliability

No.	Item	Condition	Test Time	Sample Numbers	Creteria (Acc/Rej)	Note
1	High Temp Operation	70 ± 2 °C	240 hrs	3	0/1	
2	High Temp Storage	80 ± 2 °C	240 hrs	3	0/1	
3	Low Temp Operation	-30 ± 2 °C	240 hrs	3	0/1	
4	Low Temp Storage	-40 ± 2 °C	240 hrs	3	0/1	
5	High Humidity Storage	50 °C 95%rh	504 hrs	3	0/1	
6	Thermal Shock	30mn stage -20 °C ↔70 °C	144cycles /6days	3	0/1	
7	Vibration Test	To be measured after subjecting to total fixed amplitude of 1.5mm vibrating frequency 10 to 55Hz, one cycle 60 seconds to direction of X,Y,Z for each 15 minutes,(Total 45minutes) and after removing vibration(Non-operation state)				
8	Shock Test (Drop Test)	To be measured after dropping from 150cm high onto steel board of 15mm thick and from 3 direction X,Y,Z each one time				
9	ESD	<ul style="list-style-type: none"> - Condition:150pf, 330Ω, ±8KV, 5 times Air Discharge (ESD which is made by above condition should be shot on LCD glass panel, not other's area(such as on IC and so on) - After testing, cosmetic and electrical defects should not happen. - Total current consumption should be below double of initial value. - In case of malfunction defect caused by ESD damage, if it would be recovered to normal state after resetting, it would be juded as a good part(Operation with LCM). 				
10	Solar radiation(UV)	20hours : I = 0.68 W/m ² /nm at 340 nm, T=+55 °C 4 hours : I = 0 W/m ² /nm at 340 nm, T =+35 °C				

Date : Nov. 30, 2007

TECHNICAL SPECIFICATION



LCM

HT2201L

Page 21 of 24

(4.2) In case of outgoing products 1 lot/model/week of them should applied to the following condition.

No.	Item	Condition	Test Time	Sample Numbers	Acc/Rej	Note
1	High Humidity Storage	80°C 90%RH	72 hrs	3	0/1	High Rel.
2	High Humidity Storage	80°C 90%RH	48 hrs	3	0/1	(Normal)
3	High Humidity Storage	80°C 90%RH	24 hrs	3	0/1	(Consumer)

Pressure under high temperature and high humidity as stipulated above should be conducted with the cell(LCD Panel) no polarizers attached on.

(4.3) Criteria

- a. No. 1 ~ 8 : No changes for indication and appearance.
- b. No. 1 ~ 3, 5 ~ 8 : Leave the all samples under room temperature 4 hours after reliability test ends.
- c. No. 4 : Leave the all sample under room temperature 12 hours after reliability test ends.

(5.0) Service

(5.1) We offer a satisfactory After-Service to customer.

Customer Service at HYES LCD should service the customer complaint that to HYES except that the defect is related to the reliability of product

(5.2) For these defects not listed in this specification, the customer's complaint shall be processed by the way of mutual agreement.

17. The Caution on Handling

17.1 Assembling and Mounting Method

The LCD product of HYES consists of two thin glass and polarizer which easily get damaged. So this LCD products needs special careful handling when assembling the customer's set and LCD.

17.2 The Caution on LCD handling and cleaning

When cleaning the display surface, it should be used the soft, not rough cloth by use of following materials such as Isopropyl alcohol or ethyl alcohol.

But the material which can give the damage to display surface should not be used such as water, ketone, aromatics.

ITO Pad area needs special careful caution in related with ITO corrosion. Do not wipe ITO pad area with such the materials as is able to give the damage to ITO pads. Also the material can make the ITO corrosion should not be contacted with ITO area, such as HCFC, Soldering flux, chlorine, sulfur, spittle and fingerprint.

If panel product, HYES suggest that the customer coat the UV or silicon on ITO pad area

17.3 The Caution on Electro-characteristic of LCD

The IC which is used in HYES's LCD is C-MOS LSI drivers. So to avoid from the IC damage, HYES recommend the as following contents to our customers.

Don't connect the unused input terminal to Vdd or Vss, and don't input any signal in case of not grounding the your body, working area, machine in order to protect the ESD. So to speck, this LCD product needs the ESD-free environments.

Date : Nov. 30, 2007

TECHNICAL SPECIFICATION

 HYES

LCM

HT2201L

Page 23 of 24

HYES Recommend that customer don't give the DC to LCD and limit high voltage, because DC and limit high voltage cause the undesirable deterioration of LCD and the shorter life-time.

If operating the LCD in low or high temp. chamber, the LCD could show the abnormal display such as low response time or dark display. But this phenomenon don't means the mal-function. The change of operating area to room temperature can give the recovery fo function to above LCD.

If pressing the LCD active area, LCD may show the abnormal display. But this kind's of phenomenon is not malfunction. If you reset the LCD, you can find that this phenomenon is disappeared.

7.4 Storage

The dew by water component in the ITO pad cause an open defect. Because this kinds of dew can cause the ITO corrosion. When storing the LCD in warehouse, the maximum controlled-humidity is recommended as the 55%RH or less.

If any stock for repair or other purpose, is recommended as following storage method.

- a. Store in the polyethylene bag with sealing state not to enter fresh air outside in it.
- b. Store in the dark place where neither exposure to direct sunlight nor other kind's of light.
- c. Store with no touch on polarizer surface by the anything else. If possible, store with the same packing state as HYES did.

Date : Nov. 30, 2007

TECHNICAL SPECIFICATION

 HYES

LCM

HT2201L

Page 24 of 24