



AS3932

3D Low Frequency Wakeup Receiver

1 General Description

The AS3932 is a 3-channel low power ASK receiver that is able to generate a wake-up upon detection of a data signal which uses a LF carrier frequency between 110 - 150 kHz. The integrated correlator can be used for detection of a programmable 16-bit wake-up pattern. The device can operate using one, two, or three active channels.

The AS3932 provides a digital RSSI value for each active channel, it supports a programmable data rate. The AS3932 offers a real-time clock (RTC), which is either derived from a crystal oscillator or the internal RC oscillator.

The programmable features of AS3932 enable to optimize its settings for achieving a longer distance while retaining a reliable wake-up generation. The sensitivity level of AS3932 can be adjusted in presence of a strong field or in noisy environments.

The device is available in 16-pin TSSOP and 16LD QFN (4x4) packages.

2 Key Features

- 3-channel ASK wake-up receiver
- Carrier frequency range 110 - 150 kHz
- One, two, or three channel operation
- Reliable 1-D, 2-D or 3-D wake-up pattern detection
- Programmable wake-up pattern (16bits)
- Doubling of wake-up pattern supported
- Wake-up without pattern detection supported

- Wake-up sensitivity 100 μ VRMS (typ.)
- Adjustable sensitivity level
- Highly resistant to false wake-ups
- False wake-up counter
- Periodical forced wake-up supported (1s – 2h)
- Low power listening modes
- Current consumption in 3-channel listening mode 1.7 μ A (typ.)
- Programmable data-rate 0.5 – 4 kbaud (Manchester encoded)
- Digital RSSI values available for each channel
- Dynamic range 64dB
- 5 bit RSSI step (2dB per step)
- RTC based on 32kHz XTAL, RC-OSC, or External Clock
- Operating temperature range -40°C to +85°C
- Operating supply voltage 2.4V – 3.6V (TA = 25°C)
- Bidirectional serial digital interface (SDI)
- Package option: 16-pin TSSOP, 16LD QFN (4x4)

3 Applications

The AS3932 is ideal for Active RFID tags, Real-time location systems, Operator identification, Access control, and Wireless sensors.



Figure 1. AS3932 Typical Application Diagram with Crystal Oscillator

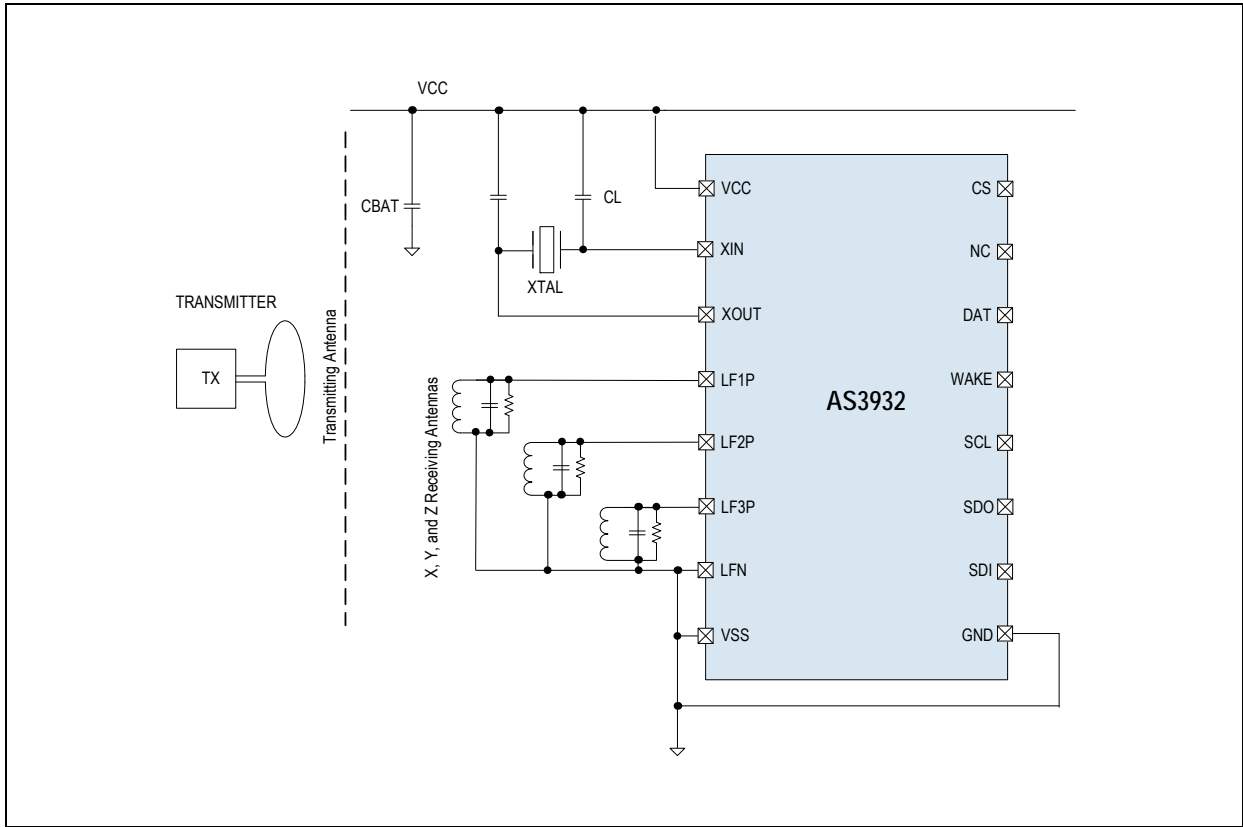

Figure 2. AS3932 Typical Application Diagram with RC Oscillator

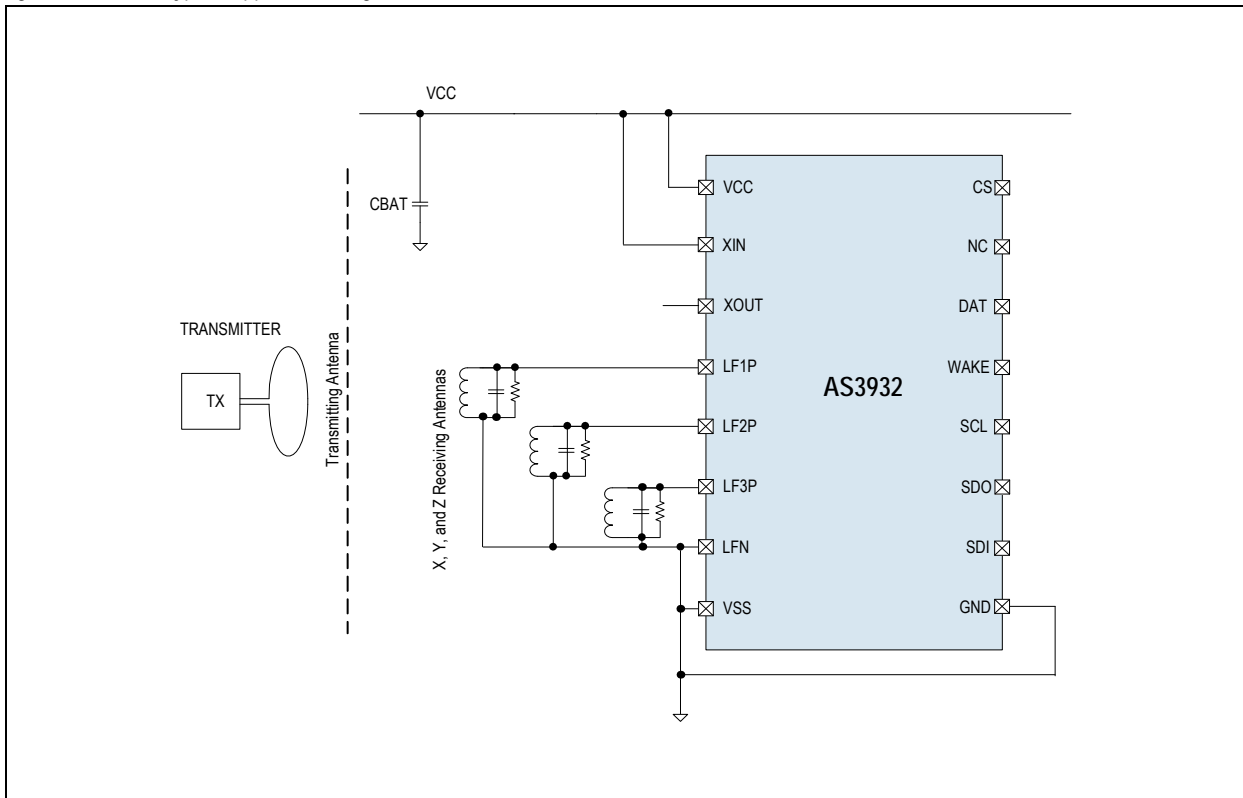
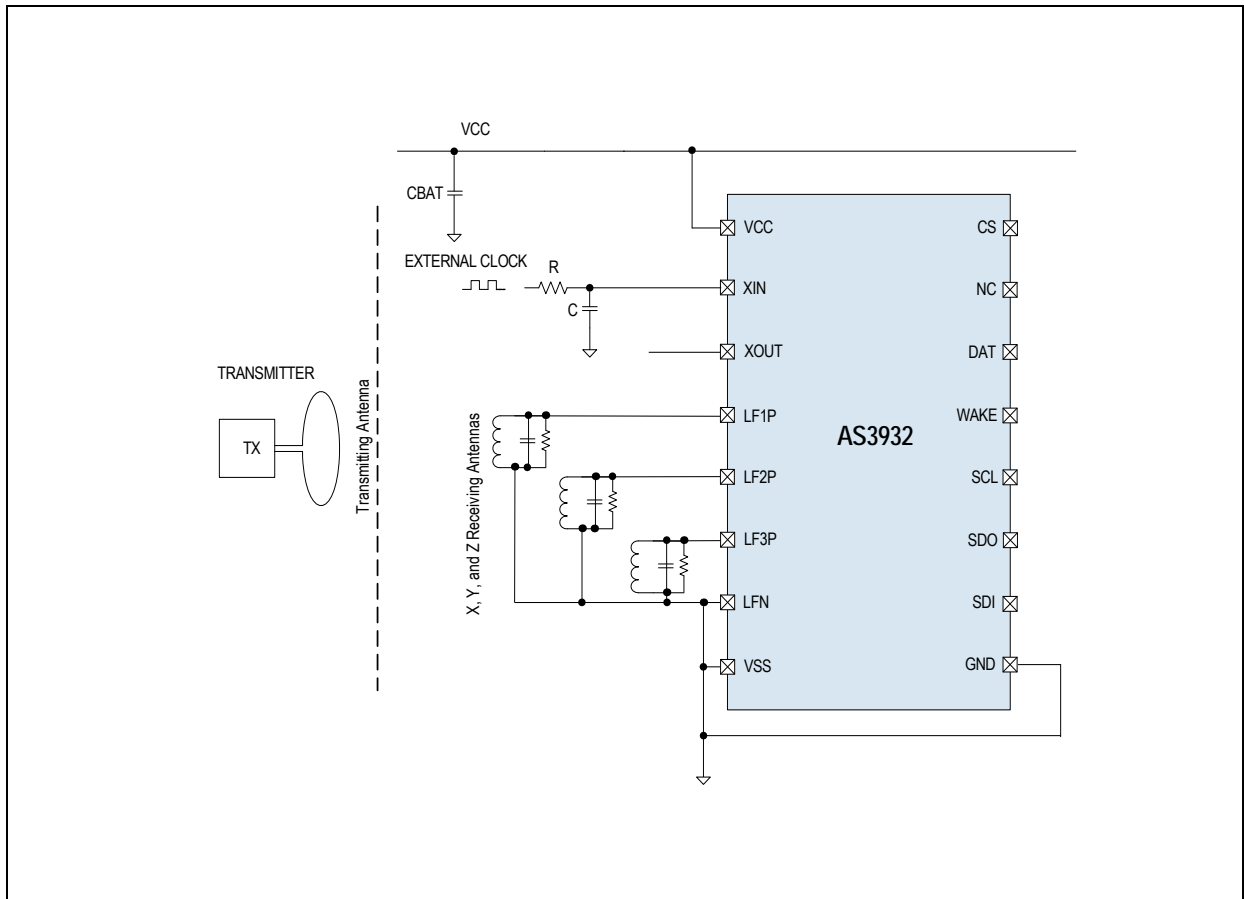



Figure 3. AS3932 Typical Application Diagram with Clock from External Source





Contents

1	General Description	1
2	Key Features.....	1
3	Applications.....	1
4	Pin Assignments	5
4.1	TSSOP Package	5
4.1.1	Pin Descriptions	5
4.2	QFN Package	6
4.2.1	Pin Descriptions	6
5	Absolute Maximum Ratings	7
6	Electrical Characteristics.....	8
7	Typical Operating Characteristics	10
8	Detailed Description.....	11
8.1	Operating Modes	12
8.1.1	Power Down Mode	12
8.1.2	Listening Mode	12
8.1.3	Preamble Detection / Pattern Correlation	13
8.1.4	Data Receiving	13
8.2	System and Block Specification	14
8.2.1	Register Table	14
8.2.2	Register Table Description and Default Values	14
8.2.3	Serial Data Interface (SDI).....	16
8.2.4	SDI Timing	19
8.3	Channel Amplifier and Frequency Detector.....	20
8.3.1	Frequency Detector / AGC	20
8.3.2	Antenna Damper.....	21
8.4	Channel Selector / Demodulator / Data Slicer.....	21
8.5	Correlator.....	22
8.6	Wake-up Protocol - Carrier Frequency 125 kHz.....	23
8.6.1	Without Pattern Detection	23
8.6.2	Single Pattern Detection	24
8.7	False Wake-up Register	26
8.8	Real Time Clock (RTC).....	27
8.8.1	Crystal Oscillator.....	28
8.8.2	RC-Oscillator	28
8.8.3	External Clock Source	29
8.9	Channel Selection in Scanning Mode and ON/OFF Mode	29
9	Package Drawings and Markings	30
10	Ordering Information.....	33



4 Pin Assignments

4.1 TSSOP Package

Figure 4. Pin Assignments 16-pin TSSOP Package

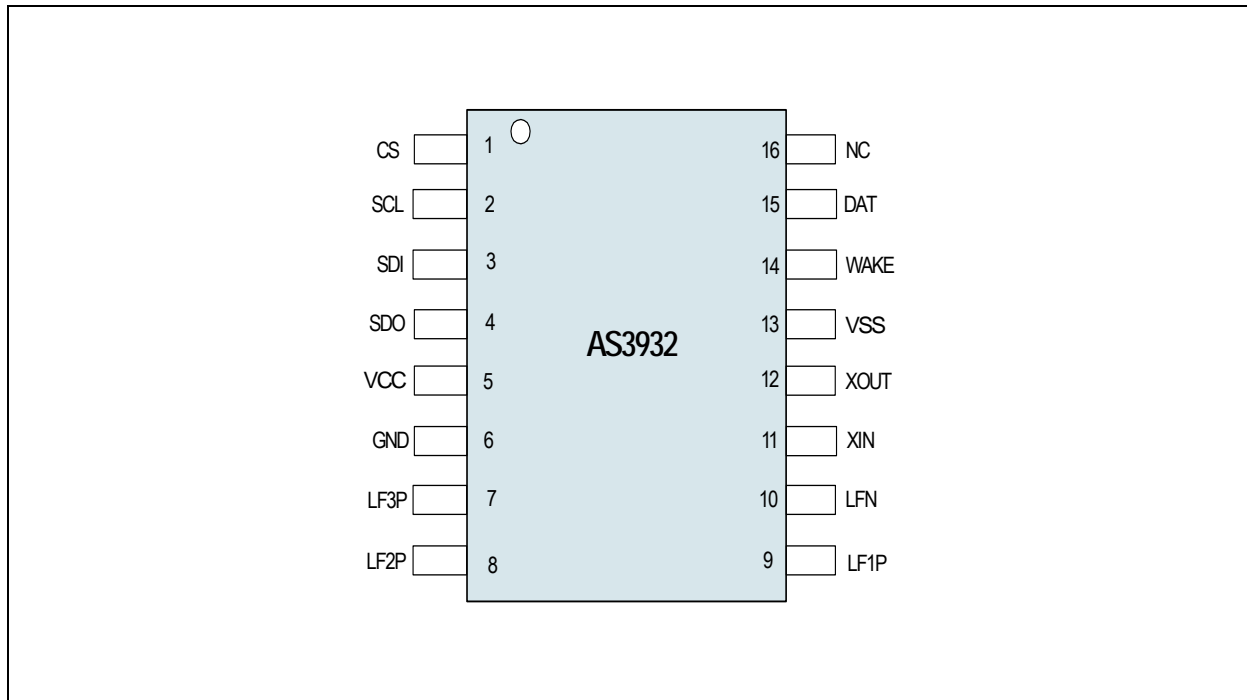

4.1.1 Pin Descriptions

Table 1. Pin Descriptions 16-pin TSSOP Package

Pin Name	Pin Number	Pin Type	Description
CS	1	Digital input	Chip select
SCL	2		SDI interface clock
SDI	3		SDI data input
SDO	4	Digital output / tristate	SDI data output (tristate when CS is low)
Vcc	5	Supply pad	Positive supply voltage
GND	6	Supply pad	Negative supply voltage
LF3P	7	Analog I/O	Input antenna channel three
LF2P	8		Input antenna channel two
LF1P	9		Input antenna channel one
LFN	10		Common ground for antenna one, two and three
XIN	11		Crystal oscillator input
XOUT	12		Crystal oscillator output
Vss	13		Supply pad
WAKE	14	Digital output	Wake-up output IRQ
DAT	15		Data output
NC	16	-	Not connected



4.2 QFN Package

Figure 5. Pin Assignments 16LD QFN (4x4) Package

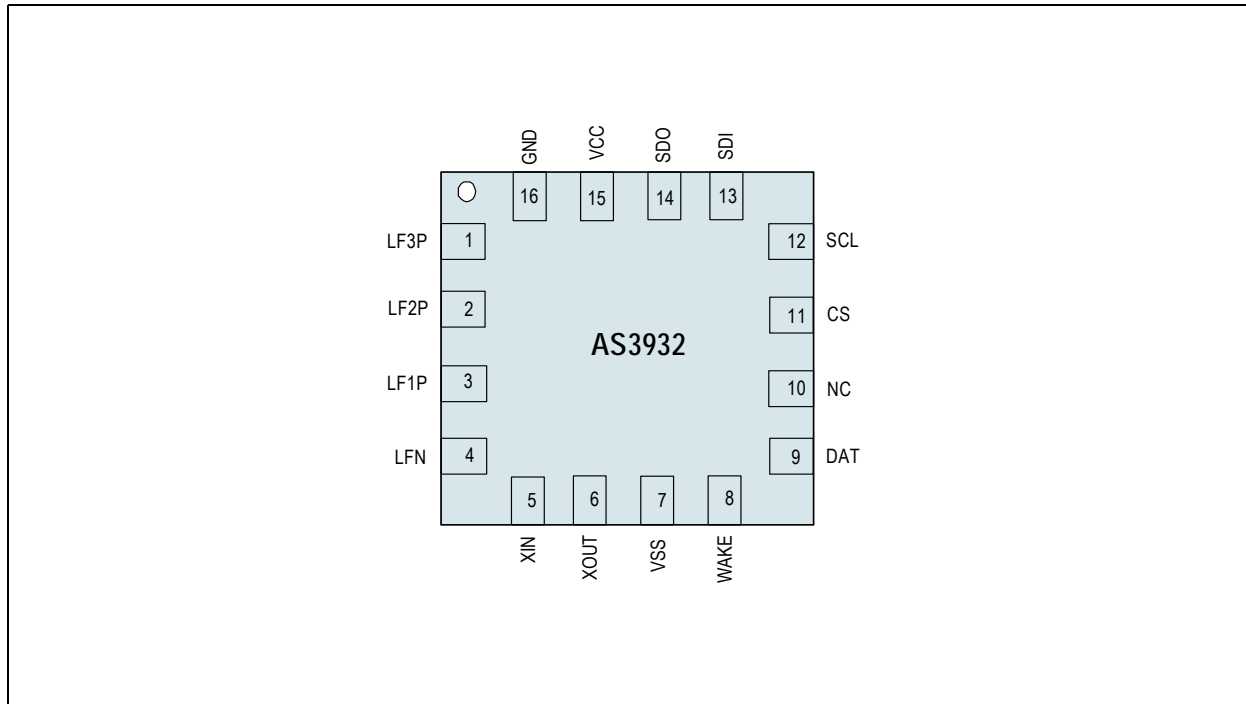

4.2.1 Pin Descriptions

Table 2. Pin Descriptions 16LD QFN (4x4) Package

Pin Name	Pin Number	Pin Type	Description
LF3P	1	Analog I/O	Input antenna channel three
LF2P	2		Input antenna channel two
LF1P	3		Input antenna channel one
LFN	4		Common ground for antenna one, two and three
XIN	5	Analog I/O	Crystal oscillator input
XOUT	6		Crystal oscillator output
VSS	7	Supply pad	Substrate
WAKE	8	Digital output	Wake-up output IRQ
DAT	9		Data output
NC	10	-	Not connected
CS	11	Digital input	Chip select
SCL	12		SDI interface clock
SDI	13		SDI data input
SDO	14	Digital output / tristate	SDI data output (tristate when CS is low)
VCC	15	Supply pad	Positive supply voltage
GND	16	Supply pad	Negative supply voltage

Note: The exposed pad has to be connected to ground.



5 Absolute Maximum Ratings

Stresses beyond those listed in [Table 3](#) may cause permanent damage to the device. These are stress ratings only. Functional operation of the device at these or any other conditions beyond those indicated in [Electrical Characteristics on page 8](#) is not implied. Exposure to absolute maximum rating conditions for extended periods may affect device reliability.

Table 3. Absolute Maximum Ratings

Parameter	Min	Max	Units	Notes
Electrical Parameters				
DC supply voltage (VDD)	-0.5	5	V	
Input pin voltage (VIN)	-0.5	5	V	
Input current (latch up immunity) (ISOURCE)	-100	100	mA	Norm: Jedec 78
Electrostatic Discharge				
Electrostatic discharge (ESD)	±2		kV	Norm: MIL 883 E method 3015 (HBM)
Continuous Power Dissipation				
Total power dissipation (all supplies and outputs) (P _t)		0.07	mW	
Temperature Ranges and Storage Conditions				
Storage temperature (T _{strg})	-65	150	°C	
Package body temperature (T _{body})		260	°C	Norm: IPC/JEDEC J-STD-020 <i>The reflow peak soldering temperature (body temperature) is specified according IPC/JEDEC J-STD-020 "Moisture/Reflow Sensitivity Classification for Non-hermetic Solid State Surface Mount Devices".</i>
Humidity non-condensing	5	85	%	
Moisture Sensitivity Level (MSL)	3			Represents a maximum floor life time of 168h



6 Electrical Characteristics

Table 4. Electrical Characteristics

Symbol	Parameter	Conditions	Min	Typ	Max	Units
Operating Conditions						
V _{DD}	Positive supply voltage		2.4		3.6	V
V _{SS}	Negative supply voltage		0		0	V
T _{AMB}	Ambient temperature		-40		85	°C
DC/AC Characteristics for Digital Inputs and Outputs						
CMOS Input						
V _{IH}	High level input voltage		0.58* V _{DD}	0.7* V _{DD}	0.83* V _{DD}	V
V _{IL}	Low level input voltage		0.125* V _{DD}	0.2* V _{DD}	0.3* V _{DD}	V
I _{LEAK}	Input leakage current				100	nA
CMOS Output						
V _{OH}	High level output voltage	With a load current of 1mA	V _{DD} - 0.4			V
V _{OL}	Low level output voltage	With a load current of 1mA			V _{SS} + 0.4	V
C _L	Capacitive load	For a clock frequency of 1 MHz			400	pF
Tristate CMOS Output						
V _{OH}	High level output voltage	With a load current of 1mA	V _{DD} - 0.4			V
V _{OL}	Low level output voltage	With a load current of 1mA			V _{SS} + 0.4	V
I _{OZ}	Tristate leakage current	to V _{DD} and V _{SS}			100	nA

Table 5. Electrical System Specifications

Symbol	Parameter	Conditions	Min	Typ	Max	Units
Input Characteristics						
R _{IN}	Input Impedance	In case no antenna damper is set (R1<4>=0)		2		MΩ
F _{min}	Minimum Input Frequency			110		kHz
F _{max}	Maximum Input Frequency			150		kHz
Current Consumption						
IPWD	Power Down Mode			400		nA
I1CHRC	Current Consumption in standard listening mode with one active channel and RC-oscillator as RTC			2.7		μA
I2CHRC	Current Consumption in standard listening mode with two active channels and RC-oscillator as RTC			4.2		μA
I3CHRC	Current Consumption in standard listening mode with three active channels and RC-oscillator as RTC			5.7	8.3	μA
I3CHSCRC	Current Consumption in scanning mode with three active channels and RC-oscillator as RTC			2.7		μA



Table 5. Electrical System Specifications

Symbol	Parameter	Conditions	Min	Typ	Max	Units
I3CHOORC	Current Consumption in ON/OFF mode with three active channels and RC-oscillator as RTC	11% Duty Cycle		1.7		μA
		50% Duty Cycle		3.45		
I3CHXT	Current Consumption in standard listening mode with three active channels and crystal oscillator as RTC			6.5	8.9	μA
IDATA	Current Consumption in Preamble detection / Pattern correlation / Data receiving mode (RC-oscillator)	With 125 kHz carrier frequency and 1kbps data-rate. No load on the output pins.		8.3	12	μA
Input Sensitivity						
SENS	Input Sensitivity on all channels	With 125 kHz carrier frequency, chip in default mode, 4 half bits burst + 4 symbols preamble and single preamble detection		100		μVrms
Channel Settling Time						
TSAMP	Amplifier settling time			250		μs
Crystal Oscillator						
FXTAL	Frequency	Crystal dependent		32.768		kHz
XTAL	Start-up Time	Crystal dependent			1	s
IXTAL	Current consumption			1		μA
External Clock Source						
IEXTCL	Current consumption			1		μA
RC Oscillator						
FRCNCAL	Frequency	If no calibration is performed	27	32.768	42	kHz
FRCCAL32	Frequency	If calibration with 32.768 kHz reference signal is performed	31	32.768	34.5	kHz
FRCCALMAX	Frequency	Maximum achievable frequency after calibration		35		kHz
FRCCALMIN	Frequency	Minimum achievable frequency after calibration		30		kHz
TCALRC	Calibration time				65	Periods of reference clock
IRC	Current consumption			200		nA



7 Typical Operating Characteristics

Figure 6. Sensitivity over Voltage and Temperature

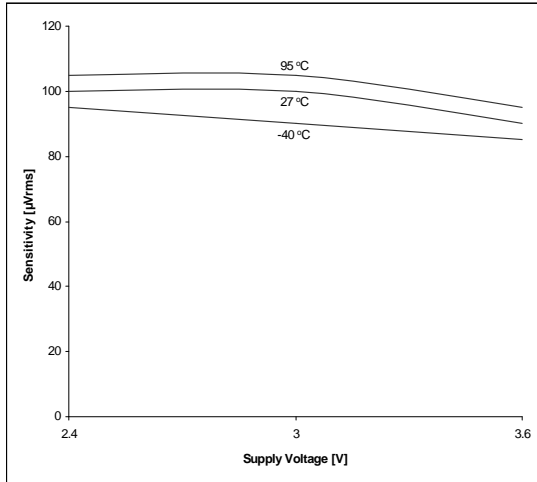

Figure 7. Sensitivity over RSSI

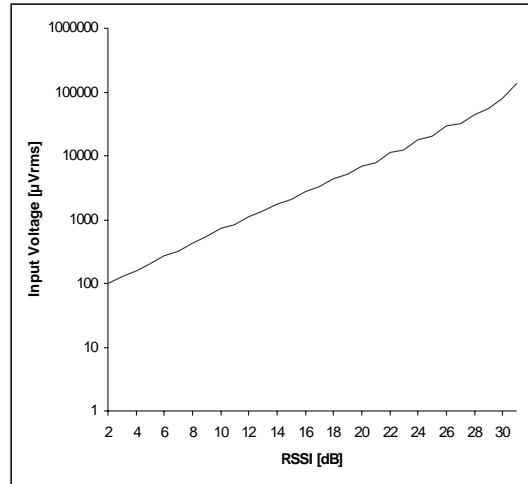

Figure 8. RC-Osc Frequency over Voltage (calibr.)

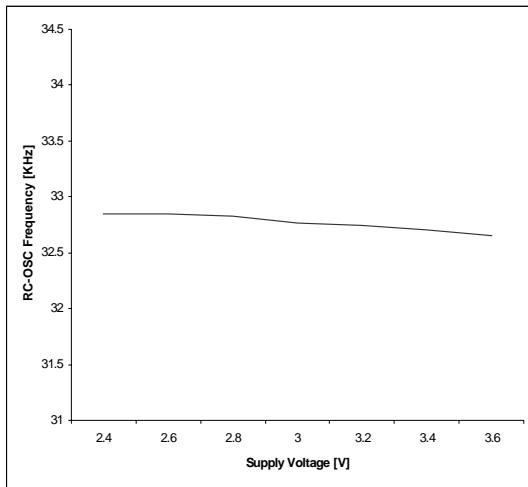
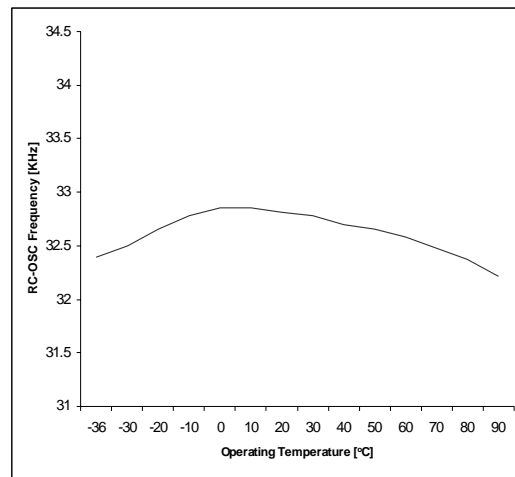

Figure 9. RC-Osc Frequency over Temperature (calibr.)





8 Detailed Description

The AS3932 is a three-dimensional low power low-frequency wake-up receiver. The AS3932 is capable to detect the presence of an inductive coupled carrier and extract the envelope of the On-Off-Keying (OOK) modulated carrier. In case the carrier is Manchester coded the clock is recovered from the transmitted signal and the data can be correlated with a programmed pattern. If the detected pattern corresponds to the stored one a wake-up signal (IRQ) is risen up. The pattern correlation can be bypassed in which case the wake-up detection is based only on the frequency detection.

The AS3932 is made up by three independent receiving channels, one envelop detector, one data correlator, 8 programmable registers with the main logic and a real time clock.

The digital logic can be accessed by an SPI. The real time clock can be based on a crystal oscillator or on an internal RC one. If the internal RC oscillator is used, a calibration procedure can be performed to improve its accuracy.

Figure 10. Block Diagram of LF Wake-up Receiver AS3932

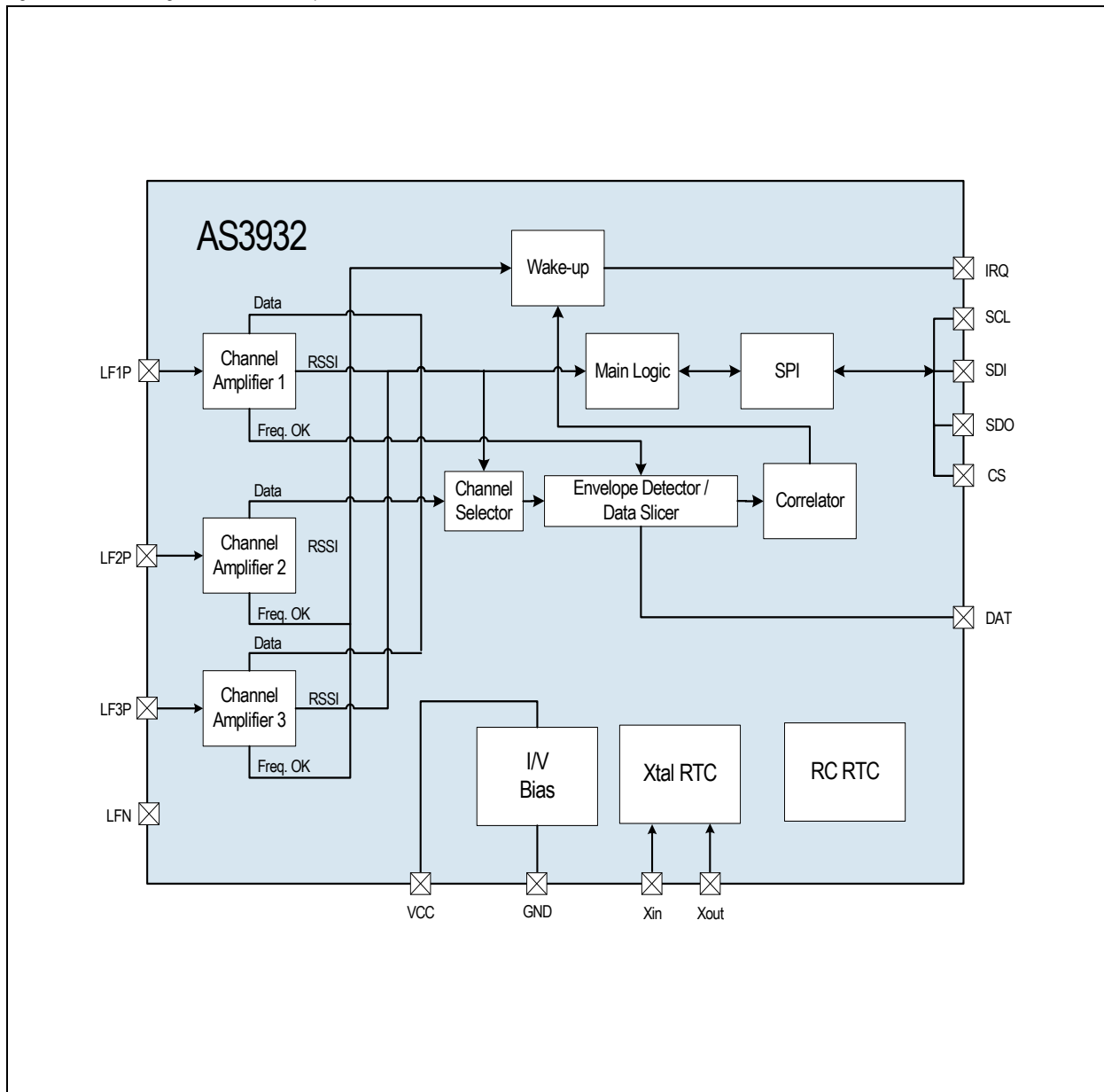



AS3932 needs the following external components:

- Power supply capacitor - CBAT – 100 nF
- 32.768 kHz crystal with its two pulling capacitors – XTAL and CL – (it is possible to omit these components if the internal RC oscillator is used instead of the crystal oscillator).
- One, two, or three LC resonators according to the number of used channels.

In case the internal RC-oscillator is used (no crystal oscillator is mounted), the pin XIN has to be connected to the supply, while pin XOUT should stay floating. Application diagrams with and without crystal are shown in [Figure 1](#) and [Figure 2](#)

8.1 Operating Modes

8.1.1 Power Down Mode

In Power Down Mode AS3932 is completely switched off. The typical current consumption is 400 nA.

8.1.2 Listening Mode

In listening mode only the active channel amplifiers and the RTC are running. In this mode the system detects the presence of a carrier. In case the carrier is detected the RSSI can be displayed.

If the three dimensional detection is not required it is possible to deactivate one or more channels. In case only two channels are required the deactivated channel must be the number two, while if only one channel detection is needed the active channel must be the number one.

Inside this mode it is possible to distinguish the following three sub modes:

Standard Listening mode. All channels are active at the same time

Scanning mode (Low Power mode 1). All used channels are active, but only one per time slot, where the time slot T is defined as 1ms. Thus, if all three channels are active the procedure is as follows (see [Figure 11](#)): for the first millisecond only channel one is active while channel two and three are powered down; for the next millisecond only channel three is active while channel one and two are powered down; finally, channel two is active while the other two are deactivated. This channel rotation goes on until the presence of the carrier is detected by any of the channels; then immediately all three channels will become active at the same time. Now AS3932 can perform a simultaneous multidirectional evaluation (on all three channels) of the field and evaluate which channel has the strongest RSSI. The channel with the highest RSSI will be put through to the demodulator. In this way it is possible to perform multidirectional monitoring of the field with a current consumption of a single channel, keeping the sensitivity as good as if all channels are active at the same time.

Figure 11. Scanning Mode

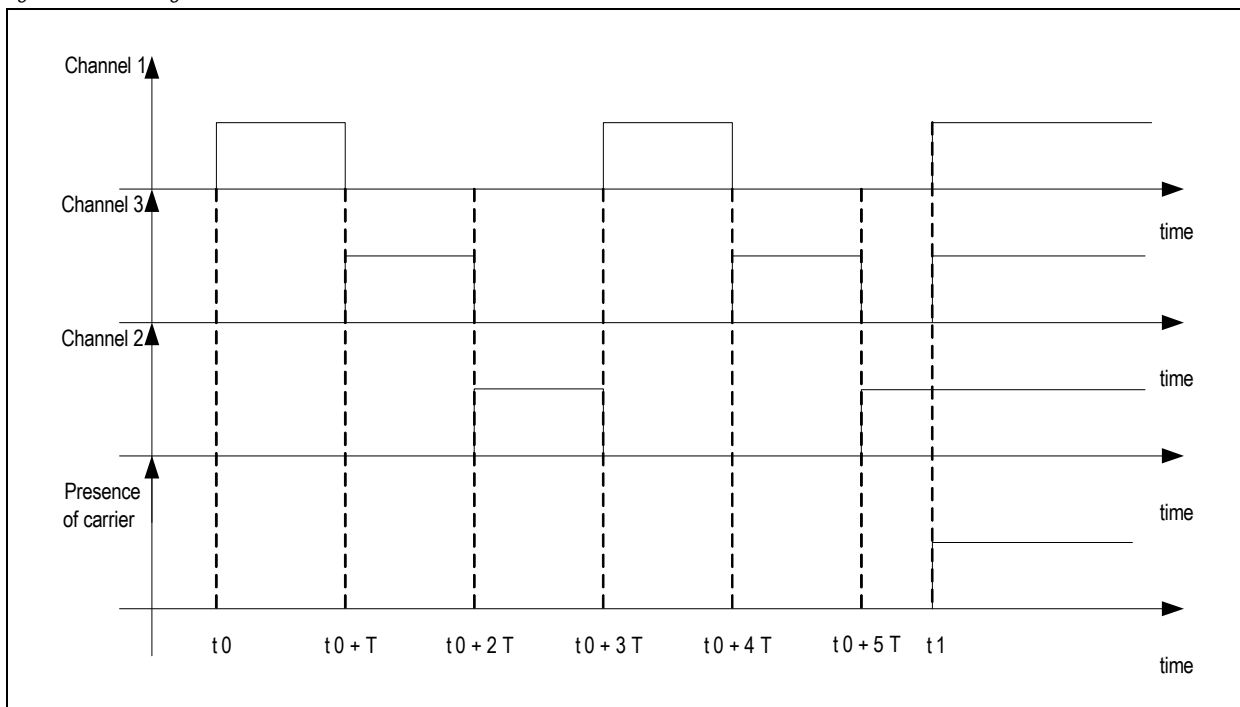



ON/OFF mode (Low Power mode 2). All active channels are on at the same time but not for the whole time (time slot T is defined as 1ms). An on-off duty-ratio is defined. This duty ratio is programmable see **R4<7:6>**.

Figure 12. ON/OFF Mode

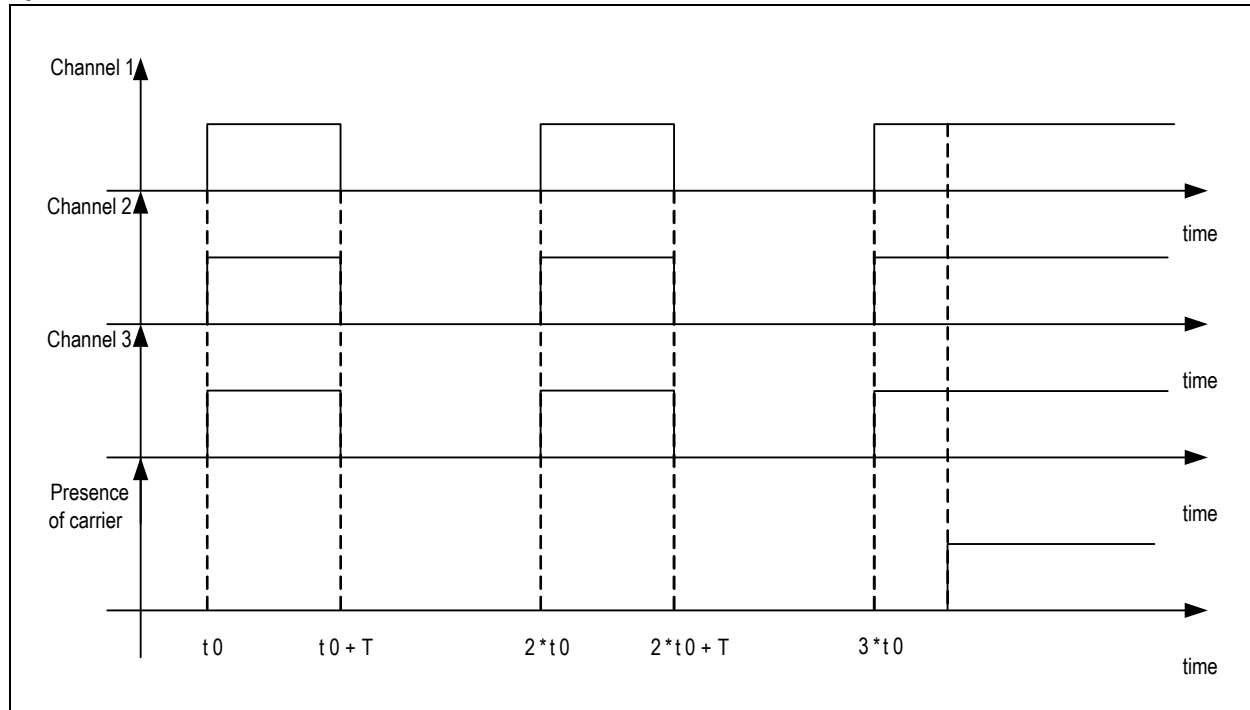

For each of these sub modes it is possible to enable a further feature called Artificial Wake-up. The Artificial Wake-up is a counter based on the used RTC. Three bits define a time window see **R8<2:0>**. If no activity is seen within this time window the chip will produce an interrupt on the WAKE pin that lasts 128 μ s. With this interrupt the microcontroller (μ C) can get feedback on the surrounding environment (e.g. read the false wake-up register **R13<7:0>**) and/or take actions in order to change the setup.

8.1.3 Preamble Detection / Pattern Correlation

The preamble detection and pattern correlation are only considered for the wake-up when the data correlator function is enabled (see **R1<1>**). The correlator searches first for preamble frequency (constant frequency of Manchester clock defined according to bit-rate transmission, see [Table 19](#)) and then for data pattern.

If the pattern is matched the wake-up interrupt is displayed on the WAKE output and the chip goes in Data receiving mode. If the pattern fails the internal wake-up (on all active channels) is terminated and no IRQ is produced.

8.1.4 Data Receiving

After a successful wake-up the chip enters the data receiving mode. In this mode the chip can be retained a normal OOK receiver. The received data are streamed out on the pin DAT. It is possible to put the chip back to listening mode either with a direct command (CLEAR_WAKE (see [Table 12](#))) or by using the timeout feature. This feature automatically sets the chip back to listening mode after a certain time **R7<7:5>**.



8.2 System and Block Specification

8.2.1 Register Table

Table 6. Register Table

	7	6	5	4	3	2	1	0
R0	n.a.		ON_OFF	MUX_123	EN_A2	EN_A3	EN_A1	PWD
R1	ABS_HY	AGC_TLIM	AGC_UD	ATT_ON		EN_PAT2	EN_WPAT	EN_RTC
R2	S_ABSH	W_PAT_T<1:0>		Reserved			S_WU1<1:0>	
R3	HY_20m	HY_POS	FS_SLC<2:0>			FS_ENV<2:0>		
R4	T_OFF<1:0>		R_VAL<1:0>		GR<3:0>			
R5	TS2<7:0>							
R6	TS1<7:0>							
R7	T_OUT<2:0>			T_HBIT<4:0>				
R8	n.a.					T_AUTO<2:0>		
R9	n.a.	Reserved						
R10	n.a.			RSSI1<4:0>				
R11	n.a.			RSSI3<4:0>				
R12	n.a.			RSSI2<4:0>				
R13	F_WAKE							

8.2.2 Register Table Description and Default Values

Table 7. Default Values of Registers

Register	Name	Type	Default Value	Description
R0<5>	ON_OFF	R/W	0	On/Off operation mode. (Duty-cycle defined in the register R4<7:6>)
R0<4>	MUX_123	R/W	0	Scan mode enable
R0<3>	EN_A2	R/W	1	Channel 2 enable
R0<2>	EN_A3	R/W	1	Channel 3 enable
R0<1>	EN_A1	R/W	1	Channel 1 enable
R0<0>	PWD	R/W	0	Power down
R1<7>	ABS_HY	R/W	0	Data slicer absolute reference
R1<6>	AGC_TLIM	R/W	0	AGC acting only on the first carrier burst
R1<5>	AGC_UD	R/W	1	AGC operating in both direction (up-down)
R1<4>	ATT_ON	R/W	0	Antenna damper enable
R1<2>	EN_PAT2	R/W	0	Double wake-up pattern correlation
R1<1>	EN_WPAT	R/W	1	Data correlation enable
R1<0>	EN_RTC	R/W	1	Crystal oscillator enable
R2<7>	S_ABSH	R/W	0	Data slicer threshold reduction
R2<6:5>	W_PAT	R/W	00	Pattern correlation tolerance (see Table 20)
R2<4:2>	Reserved		000	Reserved
R2<1:0>	S_WU1	R/W	00	Tolerance setting for the stage wake-up (see Table 14)



Table 7. Default Values of Registers

Register	Name	Type	Default Value	Description	
R3<7>	HY_20m	R/W	0	Data slicer hysteresis if HY_20m = 0 then comparator hysteresis = 40mV if HY_20m = 1 then comparator hysteresis = 20mV	
R3<6>	HY_POS	R/W	0	Data slicer hysteresis on both edges (HY_POS = 0 → hysteresis on both edges; HY_POS = 1 → hysteresis only on positive edges)	
R3<5:3>	FS_SCL	R/W	100	Data slicer time constant (see Table 18)	
R3<2:0>	FS_ENV	R/W	000	Envelop detector time constant (see Table 17)	
R4<7:6>	T_OFF	R/W	00	Off time in ON/OFF operation mode	
				T_OFF=00	1ms
				T_OFF=01	2ms
				T_OFF=10	4ms
				T_OFF=11	8ms
R4<5:4>	D_RES	R/W	01	Antenna damping resistor (see Table 16)	
R4<3:0>	GR	R/W	0000	Gain reduction (see Table 15)	
R5<7:0>	TS2	R/W	01101001	2 nd Byte of wake-up pattern	
R6<7:0>	TS1	R/W	10010110	1 st Byte of wake-up pattern	
R7<7:5>	T_OUT	R/W	000	Automatic time-out (see Table 21)	
R7<4:0>	T_HBIT	R/W	01011	Bit rate definition (see Table 19)	
R8<2:0>	T_AUTO	R/W	000	Artificial wake-up	
				T_AUTO=000	No artificial wake-up
				T_AUTO=001	1 sec
				T_AUTO=010	5 sec
				T_AUTO=011	20 sec
				T_AUTO=100	2 min
				T_AUTO=101	15min
				T_AUTO=110	1 hour
				T_AUTO=111	2 hour
R9<6:0>	Reserved		000000	Reserved	
R10<4:0>	RSSI1	R		RSSI channel 1	
R11<4:0>	RSSI2	R		RSSI channel 2	
R12<4:0>	RSSI3	R		RSSI channel 3	
R13<7:0>	F_WAK	R		False wake-up register	



8.2.3 Serial Data Interface (SDI)

This 4-wires interface is used by the Microcontroller (μC) to program the AS3932. The maximum clock frequency of the SDI is 2MHz.

Table 8. Serial Data Interface (SDI) pins

Name	Signal	Signal Level	Description
CS	Digital Input with pull down	CMOS	Chip Select
SDI	Digital Input with pull down	CMOS	Serial Data input for writing registers, data to transmit and/or writing addresses to select readable register
SDO	Digital Output	CMOS	Serial Data output for received data or read value of selected registers
SCLK	Digital Input with pull down	CMOS	Clock for serial data read and write

Note: SDO is set to tristate if CS is low. In this way more than one device can communicate on the same SDO bus.

SDI Command Structure. To program the SDI the CS signal has to go high. A SDI command is made up by a two bytes serial command and the data is sampled on the falling edge of SCLK. The Table 9 shows how the command looks like, from the MSB (B15) to LSB (B0). The command stream has to be sent to the SDI from the MSB (B15) to the LSB (B0).

Table 9. SDI Command Structure

Mode		Register address / Direct Command						Register Data							
B15	B14	B13	B12	B11	B10	B9	B8	B7	B6	B5	B4	B3	B2	B1	B0

The first two bits (B15 and B14) define the operating mode. There are three modes available (write, read, direct command) plus one spare (not used), as shown in Table 10.

Table 10. SDI Command Structure

B15	B14	Mode
0	0	WRITE
0	1	READ
1	0	NOT ALLOWED
1	1	DIRECT COMMAND

In case a write or read command happens the next 6 bits (B13 to B8) define the register address which has to be written respectively read, as shown in Table 11.

Table 11. SDI Command Structure

B13	B12	B11	B10	B9	B8	Read/Write register
0	0	0	0	0	0	R0
0	0	0	0	0	1	R1
0	0	0	0	1	0	R2
0	0	0	0	1	1	R3
0	0	0	1	0	0	R4
0	0	0	1	0	1	R5
0	0	0	1	1	0	R6
0	0	0	1	1	1	R7
0	0	1	0	0	0	R8
0	0	1	0	0	1	R9



Table 11. SDI Command Structure

B13	B12	B11	B10	B9	B8	Read/Write register
0	0	1	0	1	0	R10
0	0	1	0	1	1	R11
0	0	1	1	0	0	R12
0	0	1	1	0	1	R13

The last 8 bits are the data that has to be written respectively read. A CS toggle high-low-high terminates the command mode.

If a direct command is sent (B15-B14=11) the bits from B13 to B8 defines the direct command while the last 8 bits are omitted. The [Table 12](#) shows all possible direct commands:

Table 12. List of Direct Commands

COMMAND_MODE	B13	B12	B11	B10	B9	B8
clear_wake	0	0	0	0	0	0
reset_RSSI	0	0	0	0	0	1
trim_osc	0	0	0	0	1	0
clear_false	0	0	0	0	1	1
preset_default	0	0	0	1	0	0

All direct commands are explained below:

- clear_wake: clears the wake state of the chip. In case the chip has woken up (WAKE pin is high) the chip is set back to listening mode
- reset_RSSI: resets the RSSI measurement.
- trim_osc: starts the trimming procedure of the internal RC oscillator (see [Figure 21](#))
- clear_false: resets the false wake-up register (**R13<7:0>=00**)
- preset_default: sets all register in the default mode, as shown in [Figure 7](#)

Writing of Data to Addressable Registers (WRITE Mode). The SDI is sampled at the falling edge of SCLK (as shown in the following diagrams).

A CS toggling high-low-high indicates the end of the WRITE command after register has been written. The following example shows a write command.

Figure 13. Writing of a Single Byte (falling edge sampling)

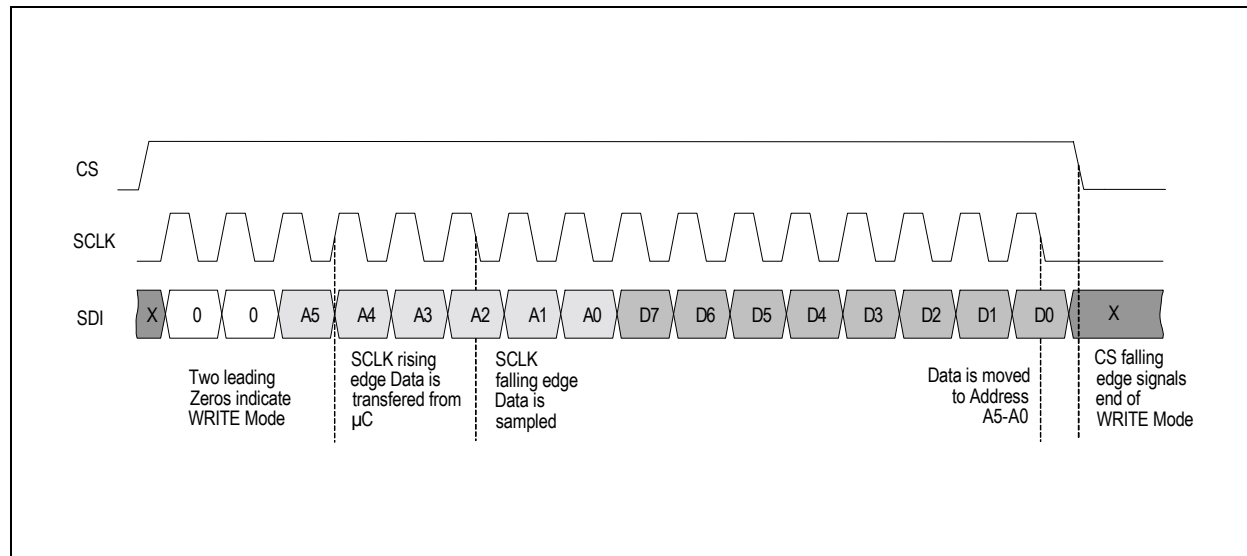
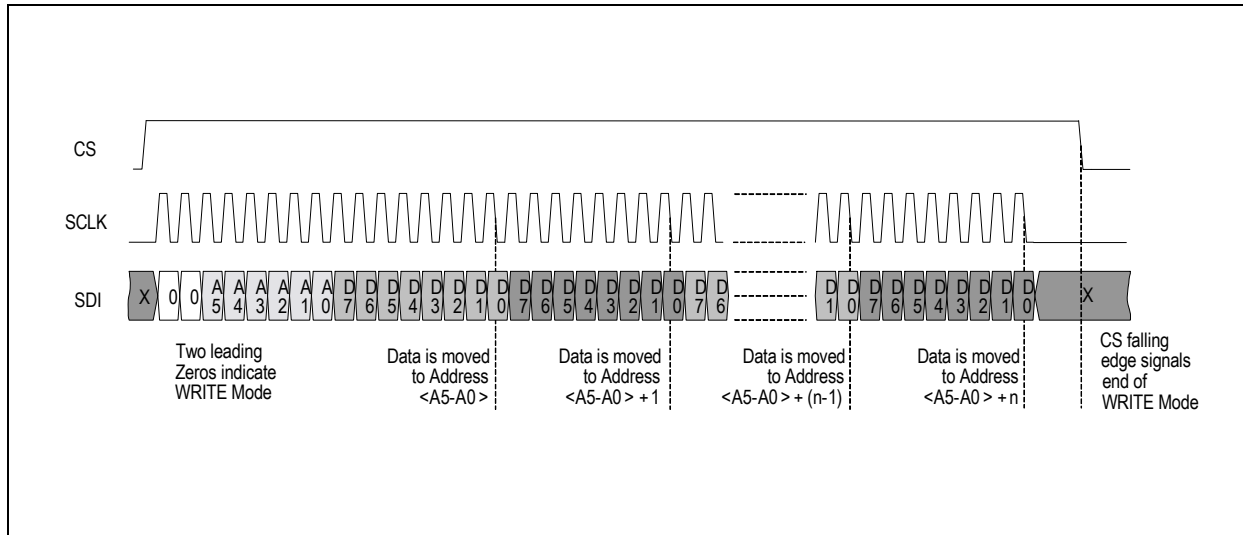



Figure 14. Writing of Register Data with Auto-incrementing Address



Reading of Data from Addressable Registers (READ Mode). Once the address has been sent through SDI, the data can be fed through the SDO pin out to the microcontroller.

A CS LOW toggling high-low-high has to be performed after finishing the read mode session, in order to indicate the end of the READ command and prepare the Interface to the next command control Byte.

To transfer bytes from consecutive addresses, SDI master has to keep the CS signal high and the SCLK clock has to be active as long as data need to be read.

Figure 15. Reading of Single Register Byte

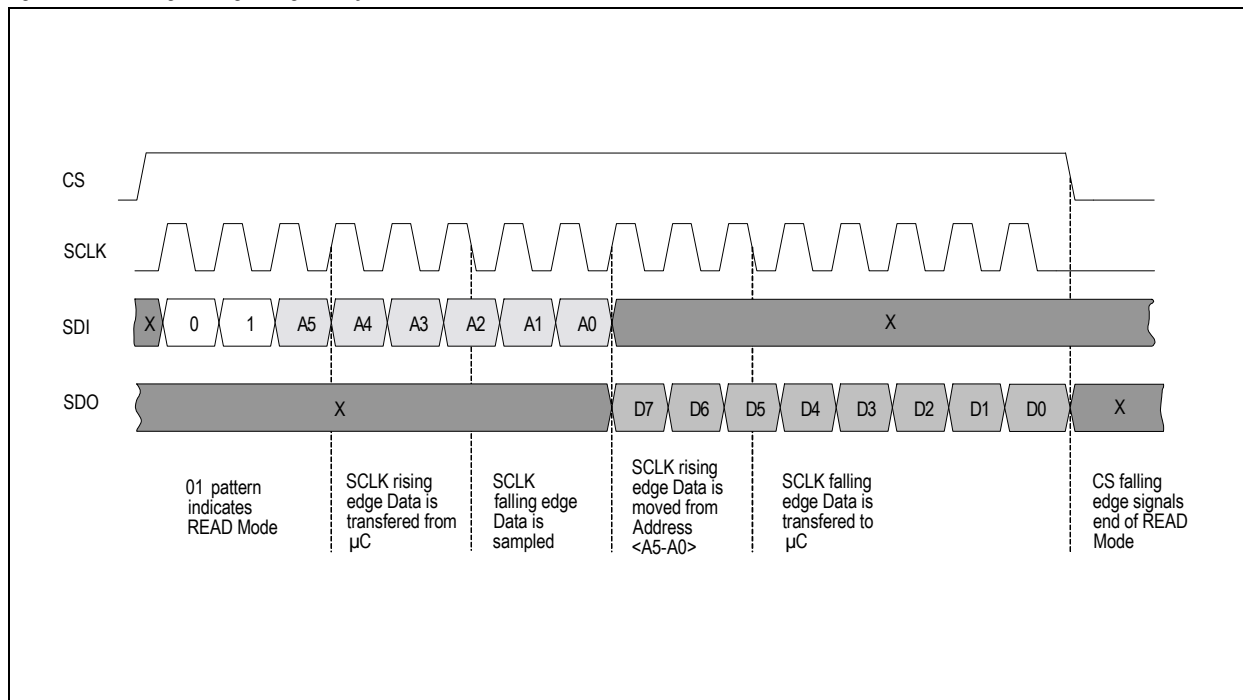
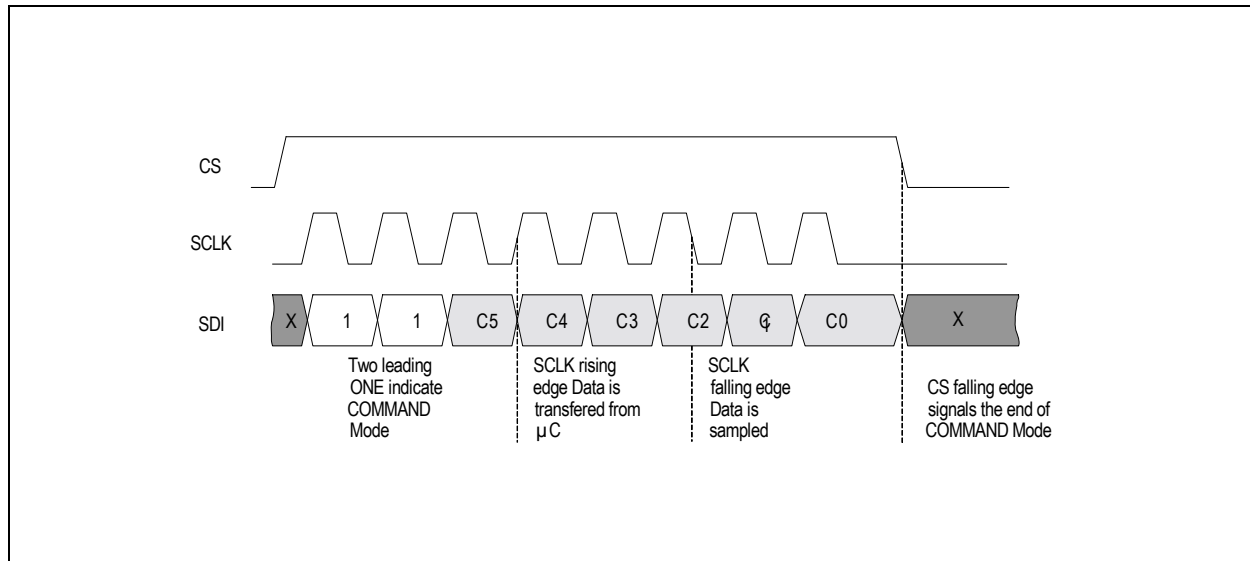



Figure 16. Send Direct COMMAND Byte



8.2.4 SDI Timing

Table 13. SDI Timing Parameters

Symbol	Parameter	Conditions	Min	Typ	Max	Units
TCCLK	Time CS to Sampling Data		500			ns
TDCLK	Time Data to Sampling Data		300			ns
THCL	SCLK High Time		200			ns
TCLK	SCLK period		1			μs
TCLKCS	Time Sampling Data to CS down		500			ns
TCST	CS Toggling time		500			ns

Figure 17. SDI Timing Diagram

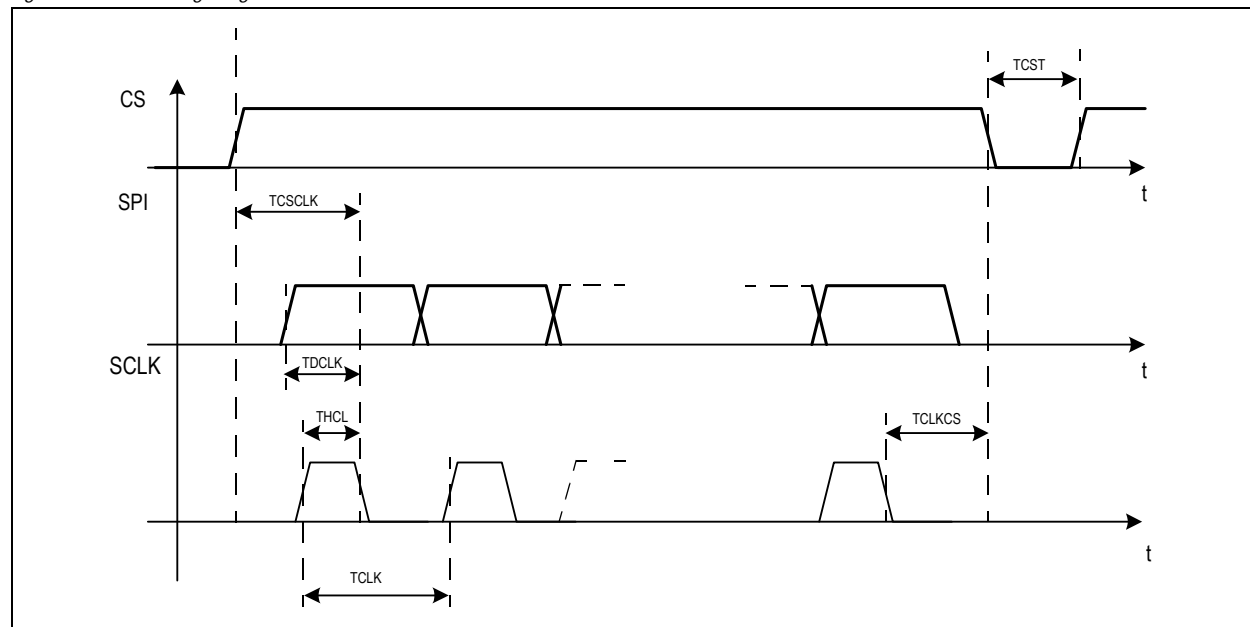



8.3 Channel Amplifier and Frequency Detector

Each of the 3 channels consists of a variable gain amplifier, an automatic gain control and a frequency detector. The latter detects the presence of a carrier. As soon as the carrier is detected the AGC is enabled, the gain of the VGA is reduced and set to the right value and the RSSI can be displayed.

It is possible to enable/disable individual channels, in case not all three channels are needed. This enables to reduce the current consumption by 1.5 μ A (typ.) per channel.

8.3.1 Frequency Detector / AGC

The frequency detection uses the RTC as time base. In case the internal RC oscillator is used as RTC, it must be calibrated, but the calibration is guaranteed for a 32.768 kHz crystal oscillator only. The frequency detection criteria can be tighter or more relaxed according to the setup described in **R2<1:0>** (see Table 14).

Table 14. Tolerance Settings for Wake-up

R2<1>	R2<0>	Tolerance
0	0	relaxed
0	1	tighter (medium)
1	0	stringent
1	1	reserved

The AGC can operate in two modes:

- AGC down only (**R1<5>**=0)
- AGC up and down (**R1<5>**=1)

As soon as the AGC starts to operate, the gain in the VGA is set to maximum. If the AGC down only mode is selected, the AGC can only decrease the gain. Since the RSSI is directly derived from the VGA gain, the system holds the RSSI peak.

When the AGC up and down mode is selected, the RSSI can follow the input signal strength variation in both directions.

Regardless which AGC operation mode is used, the AGC needs maximum 35 carrier periods to settle.

The RSSI is available for all 3 channels at the same time and it is stored in 3 registers (**R10<4:0>**, **R11<4:0>**, **R12<4:0>**)

Both AGC modes (only down or down and up) can also operate with time limitation. This option allows AGC operation only in time slot of 256 μ s following the internal wake-up. Then the AGC (RSSI) is frozen till the wake-up or RSSI reset occurs.

The RSSI is reset either with the direct command 'clear_wakeup' or 'reset_RSSI'. The 'reset_RSSI' command resets only the AGC setting but does not terminate wake-up condition. This means that if the signal is still present the new AGC setting (RSSI) will appear not later than 300 μ s (35 LF carrier periods) after the command was received. The AGC setting is reset if for duration of 3 Manchester half symbols no carrier is detected. If the wake-up IRQ is cleared the chip will go back to listening mode.

In case the maximum amplification at the beginning is a drawback (e.g. in noisy environment) it is possible to set a smaller starting gain on the amplifier, according to the Table 15. In this way it is possible to reduce the false frequency detection.

Table 15. Bit Setting of Gain Reduction

R4<3>	R4<2>	R4<1>	R4<0>	Gain reduction
0	0	0	0	no gain reduction
0	0	0	1	n.a.
0	0	1	0 or 1	n.a.
0	1	0	0 or 1	-4dB
0	1	1	0 or 1	-8dB
1	0	0	0 or 1	-12dB
1	0	1	0 or 1	-16dB
1	1	0	0 or 1	-20dB
1	1	1	0 or 1	-24dB



8.3.2 Antenna Damper

The antenna damper allows the chip to deal with higher field strength, it is enabled by register **R1<4>**. It consists of shunt resistors which degrade the quality factor of the resonator by reducing the signal at the input of the amplifier. In this way the resonator sees a smaller parallel resistance (in the band of interest) which degrades its quality factor in order to increase the linear range of the channel amplifier (the amplifier doesn't saturate in presence of bigger signals). [Table 16](#) shows the bit setup.

Table 16. Antenna Damper Bit Setup

R4<5>	R4<4>	Shunt resistor (parallel to the resonator at 125 kHz)
0	0	1 k Ω
0	1	3 k Ω
1	0	9 k Ω
1	1	27 k Ω

8.4 Channel Selector / Demodulator / Data Slicer

When at least one of three gain channel enters initial wake-up state the channel selector makes a decision which gain channel to connect to the envelope detector. If only one channel is in wake-up state the selection is obvious. If more than one channel enters wake-up state in 256 μ s following the first active channel the channel with highest RSSI value is selected. The output signal (amplified LF carrier) of selected channel is connected to the input of the demodulator.

The performance of the demodulator can be optimized according to bit rate and preamble length as described in [Table 17](#) and [Table 18](#).

Table 17. Bit Setup for the Envelop Detector for Different Symbol Rates

R3<2>	R3<1>	R3<0>	Symbol rate [Manchester symbols/s]
0	0	0	4096
0	0	1	2184
0	1	0	1490
0	1	1	1130
1	0	0	910
1	0	1	762
1	1	0	655
1	1	1	512

If the bit rate gets higher the time constant in the envelop detector must be set to a smaller value. This means that higher noise is injected because of the wider band. The next table is a rough indication of how the envelop detector looks like for different bit rates. By using proper data slicer settings it is possible to improve the noise immunity paying the penalty of a longer preamble. In fact if the data slicer has a bigger time constant it is possible to reject more noise, but every time a transmission occurs, the data slicer need time to settle. This settling time will influence the length of the preamble. [Table 18](#) gives a correlation between data slicer setup and minimum required preamble length.

Table 18. Bit Setup for the Data Slicer for Different Preamble Length

R3<5>	R3<4>	R3<3>	Minimum preamble length [ms]
0	0	0	0.8
0	0	1	1.15
0	1	0	1.55
0	1	1	1.9
1	0	0	2.3
1	0	1	2.65
1	1	0	3
1	1	1	3.5



Note: These times are minimum required, but it is recommended to prolong the preamble.

The comparator of the data slicer can work only with positive or with symmetrical threshold (**R3<6>**). In addition the threshold can be 20 or 40 mV (**R3<7>**)

In case the length of the preamble is an issue the data slicer can also work with an absolute threshold (**R1<7>**). In this case the bits **R3<2:0>** would not influence the performance. It is even possible to reduce the absolute threshold in case the environment is not particularly noisy (**R2<7>**).

8.5 Correlator

After frequency detection the data correlation is only performed if the correlator is enabled (**R1<1>=1**).

The data correlation consists of checking the presence of a preamble (ON/OFF modulated carrier) followed by a certain pattern.

After the frequency detection the correlator waits 16 bits (see bit rate definition in [Table 19](#)) and if no preamble is detected the chip is set back to listening mode and the false wake-up register (**R13<7:0>**) is incremented by one.

To get started with the pattern correlation the correlator needs to detect at least 4 bits of the preamble (ON/OFF modulated carrier).

The bit duration is defined in the register **R7<4:0>** according to the [Table 19](#) as function of the Real Time Clock (RTC) periods.

Table 19. Bit Rate Setup

R7<4>	R7<3>	R7<2>	R7<1>	R7<0>	Bit duration in RTC clock periods	Bit rate (bits/s)	Symbol rate (Manchester symbols/s)
0	0	0	1	1	4	8192	4096
0	0	1	0	0	5	6552	3276
0	0	1	0	1	6	5460	2730
0	0	1	1	0	7	4680	2340
0	0	1	1	1	8	4096	2048
0	1	0	0	0	9	3640	1820
0	1	0	0	1	10	3276	1638
0	1	0	1	0	11	2978	1489
0	1	0	1	1	12	2730	1365
0	1	1	0	0	13	2520	1260
0	1	1	0	1	14	2340	1170
0	1	1	1	0	15	2184	1092
0	1	1	1	1	16	2048	1024
1	0	0	0	0	17	1926	963
1	0	0	0	1	18	1820	910
1	0	0	1	0	19	1724	862
1	0	0	1	1	20	1638	819
1	0	1	0	0	21	1560	780
1	0	1	0	1	22	1488	744
1	0	1	1	0	23	1424	712
1	0	1	1	1	24	1364	682
1	1	0	0	0	25	1310	655
1	1	0	0	1	26	1260	630
1	1	0	1	0	27	1212	606
1	1	0	1	1	28	1170	585
1	1	1	0	0	29	1128	564



Table 19. Bit Rate Setup

R7<4>	R7<3>	R7<2>	R7<1>	R7<0>	Bit duration in RTC clock periods	Bit rate (bits/s)	Symbol rate (Manchester symbols/s)
1	1	1	0	1	30	1092	546
1	1	1	1	0	31	1056	528
1	1	1	1	1	32	1024	512

If the preamble is detected correctly the correlator keeps searching for a data pattern. The duration of the preamble plus the pattern should not be longer than 40 bits (see bit rate definition in Table 19). The data pattern can be defined by the user and consists of two bytes which are stored in the registers **R5<7:0>** and **R6<7:0>**. The two bytes define the pattern consisting of 16 half bit periods. This means the pattern and the bit period can be selected by the user. The only limitation is that the pattern (in combination with preamble) must obey Manchester coding and timing. It must be noted that according to Manchester coding a down-to-up bit transition represents a symbol "0", while a transition up-to-down represents a symbol "1". If the default code is used (96 [hex]) the binary code is (10 01 01 10 01 10 10 01). MSB has to be transmitted first.

The user can also select (**R1<2>**) if single or double data pattern is used for wake-up. In case double pattern detection is set, the same pattern has to be repeated 2 times.

Additionally it is possible to set the number of allowed missing zero bits (not symbols) in the received bitstream (**R2<6:5>**), as shown in the Table 20.

Table 20. Allowed Pattern Detection Errors

R2<6>	R2<5>	Maximum allowed error in the pattern detection
0	0	No error allowed
0	1	1 missed zero
1	0	2 missed zeros
1	1	3 missed zeros

If the pattern matches the wake-up, interrupt is displayed on the WAKE output.

If the pattern detection fails, the internal wake-up (on all active channels) is terminated with no signal sent to MCU and the false wake-up register will be incremented (**R13<7:0>**).

8.6 Wake-up Protocol - Carrier Frequency 125 kHz

The wake-up state is terminated with the direct command 'clear_wake' Table 12. This command terminates the MCU activity. The termination can also be automatic in case there is no response from MCU. The time out for automatic termination is set in a register **R7<7:5>**, as shown in the Table 21.

Table 21. Timeout Setup

R7<7>	R7<6>	R7<5>	Time out
0	0	0	0 sec
0	0	1	50 msec
0	1	0	100 msec
0	1	1	150 msec
1	0	0	200 msec
1	0	1	250 msec
1	1	0	300 msec
1	1	1	350 msec



8.6.1 Without Pattern Detection

Figure 18. Wake-up Protocol Overview without Pattern Detection (only carrier frequency detection)

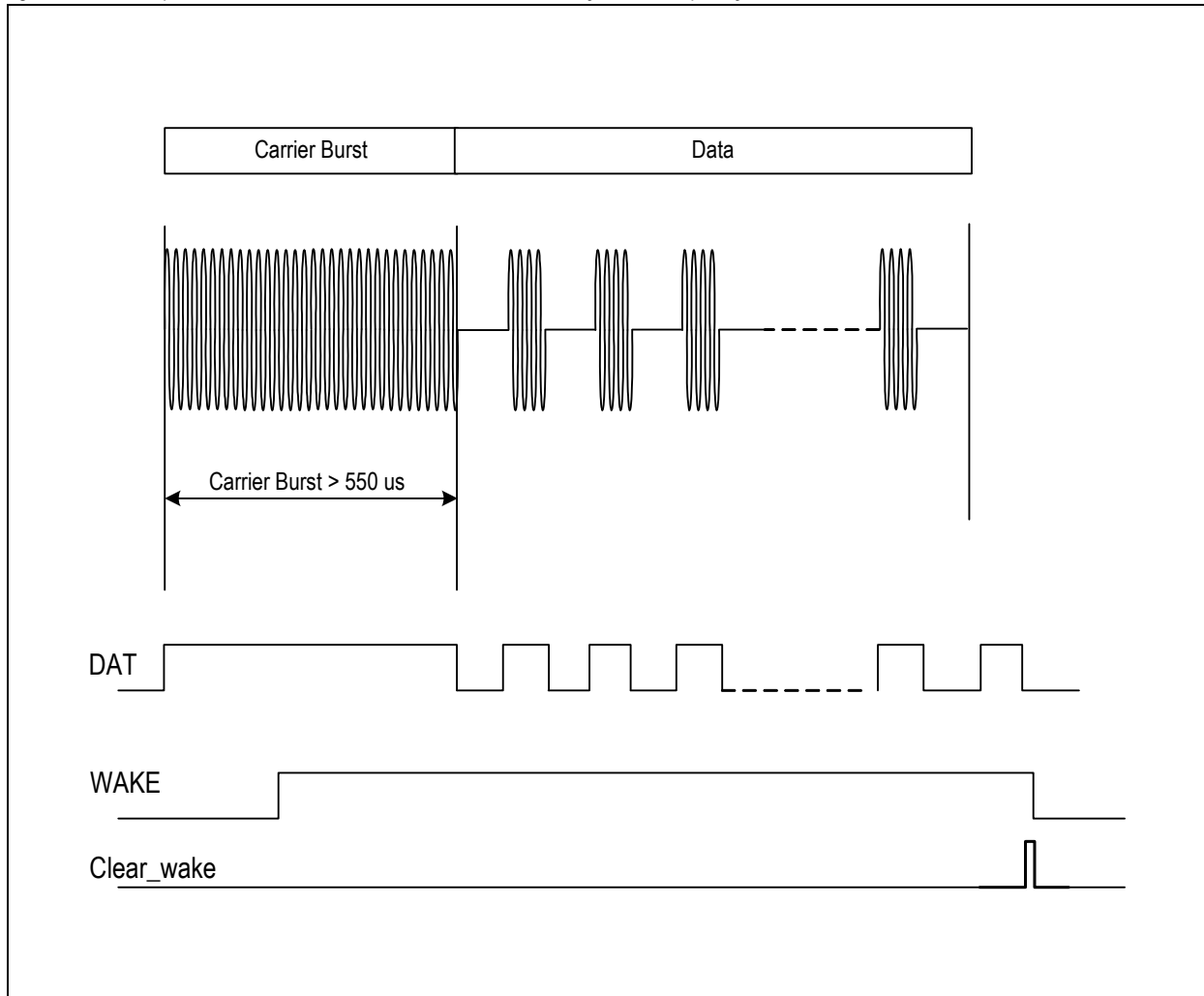

In case the data correlation is disabled ($R1<1>=0$) the AS3932 wakes up upon detection of the carrier frequency only as shown in Figure 18. In order to ensure that AS3932 wakes up the carrier burst has to last longer than 550 μ s. To set AS3932 back to listening mode there are two possibilities: either the microcontroller sends the direct command `clear_wake` via SDI or the time out option is used ($R7<7:5>$). In case the latter is chosen, AS3932 is automatically set to listening mode after the time defined in T_OUT ($R7<7:5>$), counting starts at the low-to-high WAKE edge on the WAKE pin.

8.6.2 Single Pattern Detection

The Figure 19 shows the wake-up protocol in case the pattern correlation is enabled ($R1<1>=1$) for a 125 kHz carrier frequency. The initial carrier burst has to be longer than 550 μ s and can last maximum 16 bits (see bit rate definition in Table 19). If the ON/OFF mode is used ($R1<5>=1$), the minimum value of the maximum carrier burst duration is limited to 10 ms. This is summarized in Table 22. In case the carrier burst is too long the internal wake-up will be set back to low and the false wake-up counter ($R13<7:0>$) will be incremented by one. The carrier burst must be followed by a preamble (0101... modulated carrier with a bit duration defined in Table 19) and the wake-up pattern stored in the registers $R5<7:0>$ and $R6<7:0>$. The preamble must have at least 4 bits and the preamble duration together with the pattern should not be longer than 40 bits. If the wake-up pattern is correct, the signal on the WAKE pin goes high one bit after the end of the pattern and the data transmission can get started. To set the chip back to listening mode the direct command `clear_wake`, as well as the time out option ($R7<7:5>$) can be used.



Figure 19. Wake-up Protocol Overview with Single Pattern Detection

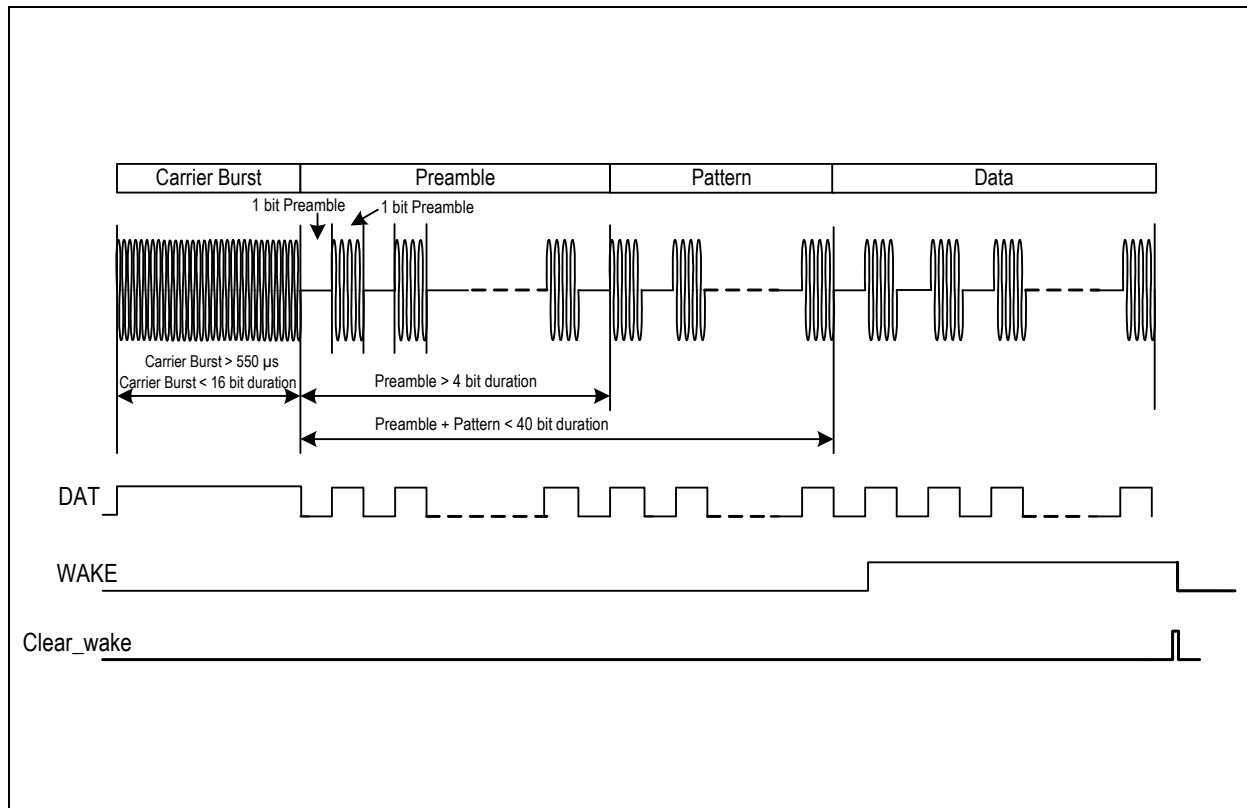

Table 22. Preamble Requirements in Standard Mode, Scanning Mode and ON/OFF Mode

Bit rate (bit/s)	Maximum duration of the carrier burst in Standard Mode and Scanning Mode (ms)	Maximum duration of the carrier burst in ON/OFF Mode (ms)
8192	1.95	10
6552	2.44	10
5460	2.93	10
4680	3.41	10
4096	3.90	10
3640	4.39	10
3276	4.88	10
2978	5.37	10
2730	5.86	10
2520	6.34	10
2340	6.83	10
2184	7.32	10
2048	7.81	10
1926	8.30	10
1820	8.79	10
1724	9.28	10
1638	9.76	10



Table 22. Preamble Requirements in Standard Mode, Scanning Mode and ON/OFF Mode

Bit rate (bit/s)	Maximum duration of the carrier burst in Standard Mode and Scanning Mode (ms)	Maximum duration of the carrier burst in ON/OFF Mode (ms)
1560	10.25	10.25
1488	10.75	10.75
1424	11.23	11.23
1364	11.73	11.73
1310	12.21	12.21
1260	12.69	12.69
1212	13.20	13.20
1170	13.67	13.67
1128	14.18	14.18
1092	14.65	14.65
1056	15.15	15.15
1024	15.62	15.62

8.7 False Wake-up Register

The wake-up strategy in the AS3932 is based on 2 steps:

1. Frequency Detection: in this phase the frequency of the received signal is checked.
2. Pattern Correlation: here the pattern is demodulated and checked whether it corresponds to the valid one.

If there is a disturber or noise capable to overcome the first step (frequency detection) without producing a valid pattern, then a false wake-up call happens. Each time this event is recognized a counter is incremented by one and the respective counter value is stored in a memory cell (false wake-up register). Thus, the microcontroller can periodically look at the false wake-up register, to get a feeling how noisy the surrounding environment is and can then react accordingly (e.g. reducing the gain of the LNA during frequency detection, set the AS3932 temporarily to power down etc.), as shown in the [Figure 20](#). The false wake-up counter is a useful tool to quickly adapt the system to any changes in the noise environment and thus avoid false wake-up events.

Most wake-up receivers have to deal with environments that can rapidly change. By periodically monitoring the number of false wake-up events it is possible to adapt the system setup to the actual characteristics of the environment and enables a better use of the full flexibility of AS3932.



Figure 20. Concept of the False Wake-up Register together with the system

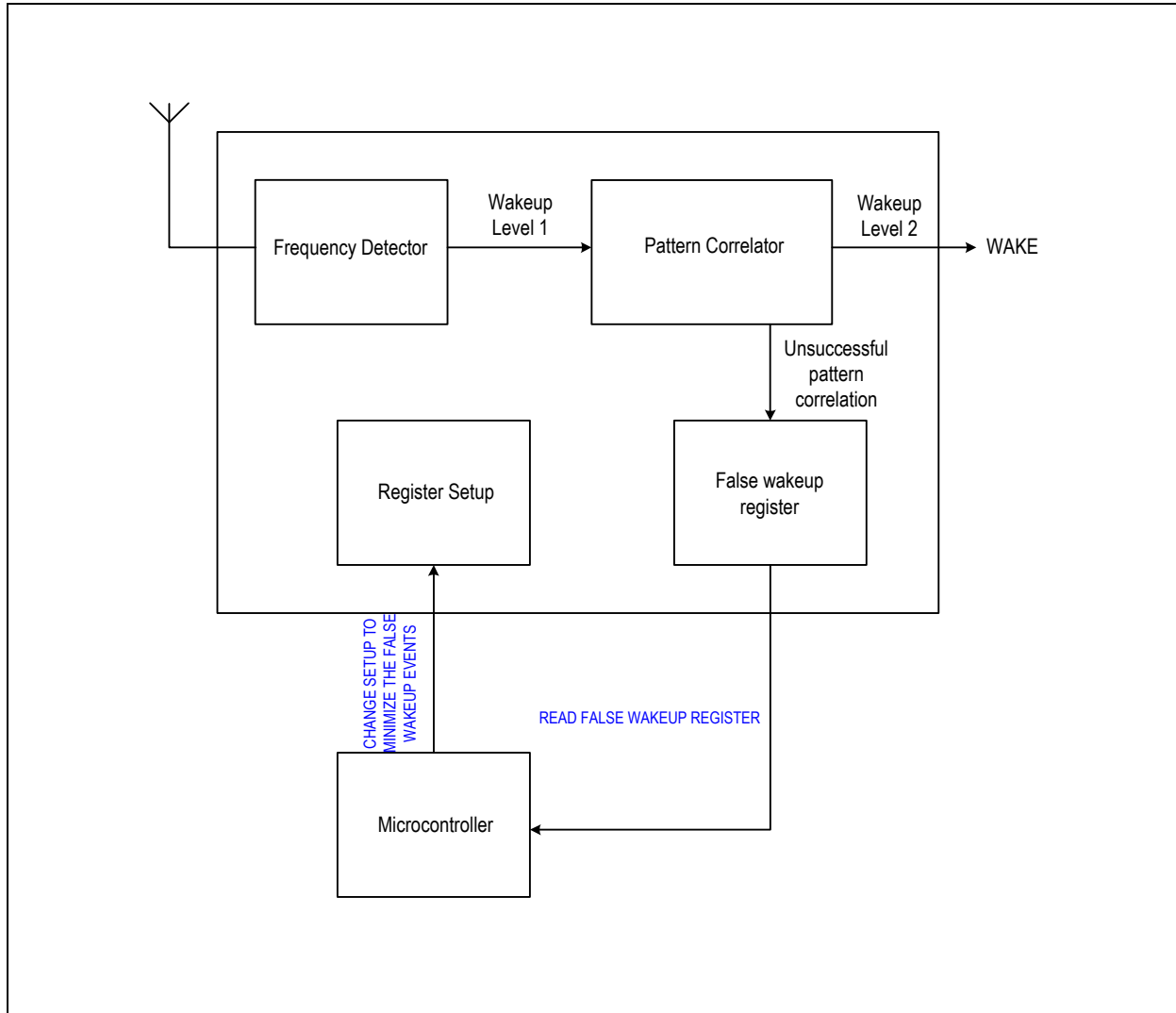

8.8 Real Time Clock (RTC)

The RTC can be based on a crystal oscillator ($R1<0>=1$), the internal RC-oscillator ($R1<0>=0$), or an external clock source ($R1<0>=1$). The crystal oscillator has higher precision of the frequency with higher current consumption and needs three external components (crystal plus two capacitors). The RC-oscillator is completely integrated and can be calibrated if a reference signal is available for a very short time to improve the frequency accuracy. The calibration gets started with the `trim_osc` direct command. Since no non-volatile memory is available the calibration must be done every time after the RCO is turned off. The RCO is turned off when the chip is in power down mode, a POR happened, or the crystal oscillator is enabled. Since the RTC defines the time base of the frequency detection, the selected frequency (frequency of the crystal oscillator or the reference frequency used for calibration of the RC oscillator) should be about one forth of the carrier frequency:

$$F_{RTC} \sim F_{CAR} * 0.25 \quad (EQ 1)$$

Where: F_{CAR} is the carrier frequency and F_{RTC} is the RTC frequency

The third option for the RTC is the use of an external clock source, which must be applied directly to the XIN pin (XOUT floating).



8.8.1 Crystal Oscillator

Table 23. Characteristics of XTAL

Symbol	Parameter	Conditions	Min	Typ	Max	Units
	Crystal accuracy (initial)	Overall accuracy			±120	p.p.m.
	Crystal motional resistance				60	KΩ
	Frequency			32.768		kHz
	Contribution of the oscillator to the frequency error			±5		p.p.m
	Start-up Time	Crystal dependent		1		s
	Duty cycle		45	50	55	%
	Current consumption			1		μA

8.8.2 RC-Oscillator

Table 24. Characteristics of RCO

Symbol	Parameter	Conditions	Min	Typ	Max	Units
	Frequency	If no calibration is performed	27	32.768	42	kHz
		If calibration is performed	31	32.768	34.5	kHz
	Calibration time	Periods of reference clock			65	cycles
	Current consumption			200		nA

To trim the RC-Oscillator, set the chip select (CS) to high before sending the direct command trim_osc over SDI. Then 65 digital clock cycles of the reference clock (e.g. 32.768 kHz) have to be sent on the clock bus (SCLK), as shown in Figure 21. After that the signal on the chip select (CS) has to be pulled down.

The calibration is effective after the 65th reference clock edge and it will be stored in a volatile memory. In case the RC-oscillator is switched off or a power-on-reset happens (e.g. battery change) the calibration has to be repeated.

Figure 21. RC-Oscillator Calibration via SDI

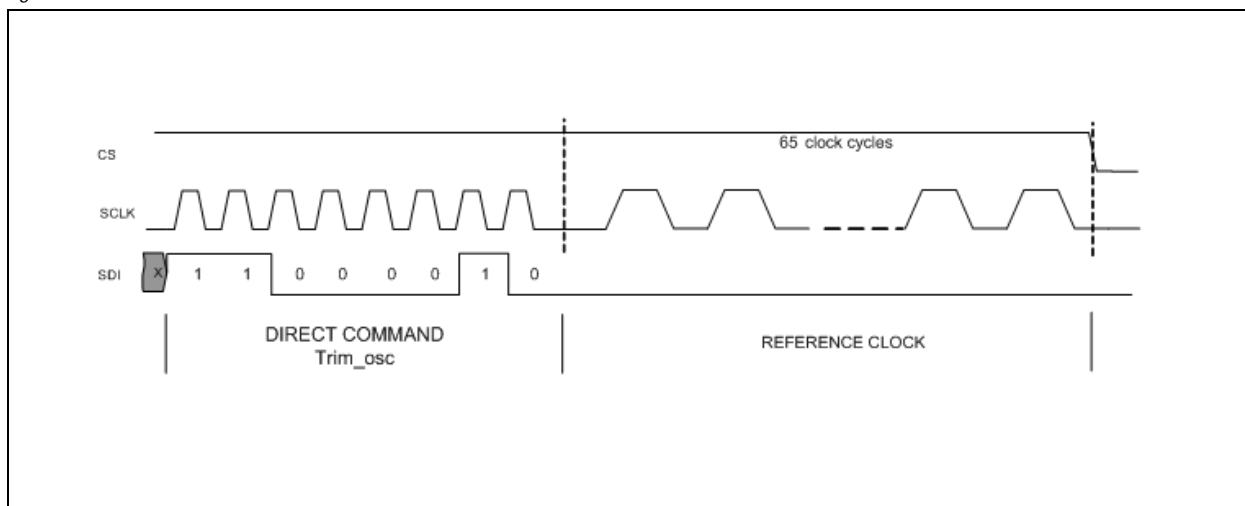



8.8.3 External Clock Source

To clock the AS3932 with an external signal the crystal oscillator has to be enabled ($R1<0>=1$). As shown in the [Figure 3](#) the clock must be applied on the pin XIN while the pin XOUT must stay floating. The RC time constant has to be $15\mu\text{s}$ with a tolerance of $\pm 10\%$ (e.g. $R=680\text{ k}\Omega$ and $C=22\text{pF}$). In the [Table 25](#) the clock characteristics are summarized.

Table 25. Characteristics of External Clock

Symbol	Parameter	Conditions	Min	Typ	Max	Units
VI	Low level		0		$0.1 * V_{DD}$	V
Vh	High level		$0.9 * V_{DD}$		V_{DD}	V
Tr	Rise-time				3	μs
Tf	Fall-time				3	μs
T = RC	RC Time constant		13.5	15	16.5	μs

Note: In power down mode the external clock has to be set to V_{DD} .

8.9 Channel Selection in Scanning Mode and ON/OFF Mode

In case only 2 channels are active and one of the Low Power modes is enabled, then the channels 1 and 3 have to be active. If the chip works in On-Off mode and only one channel is active then the active channel has to be the channel 1.

Both Low Power modes are not allowed to be enabled at the same time.



9 Package Drawings and Markings

The product is available in a 16-pin TSSOP package.

Figure 22. Drawings and Dimensions

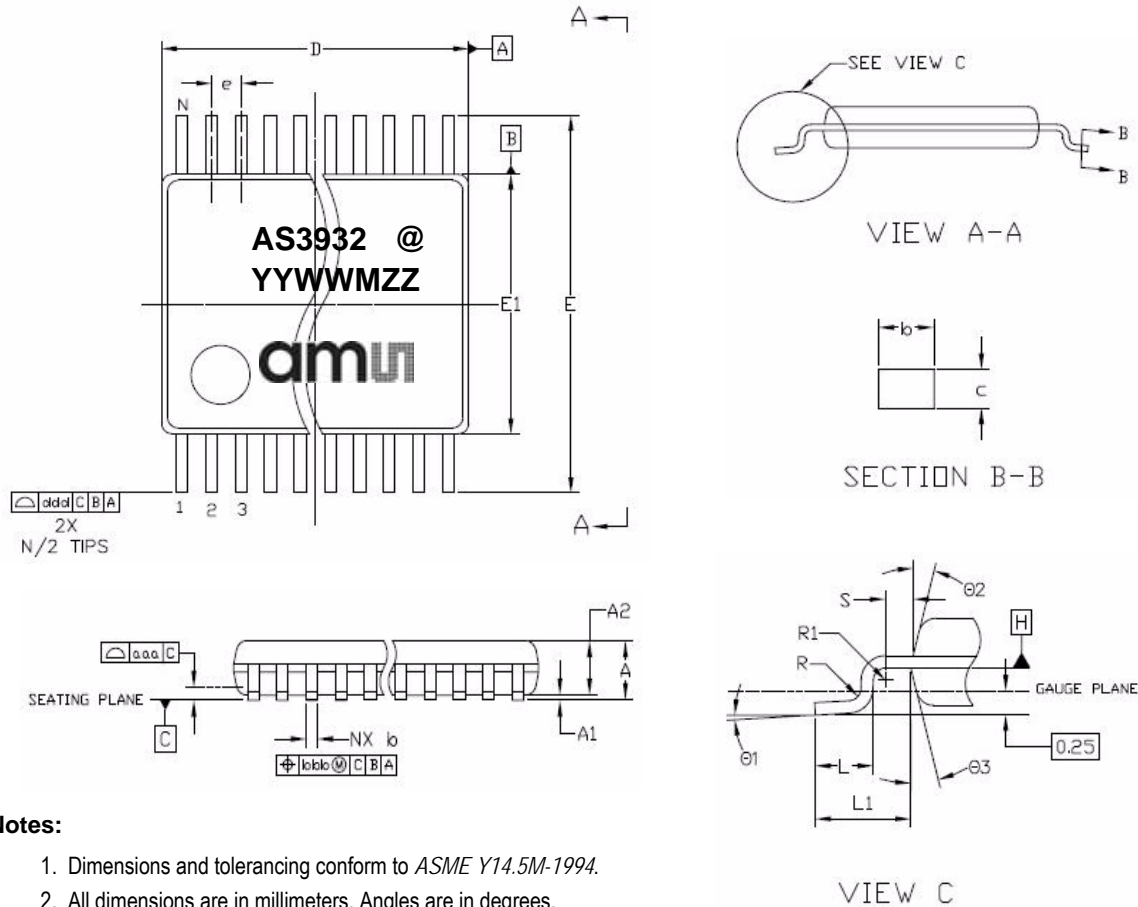

Notes:

1. Dimensions and tolerancing conform to ASME Y14.5M-1994.
2. All dimensions are in millimeters. Angles are in degrees.

Symbol	Min	Nom	Max
A	-	-	1.20
A1	0.05	-	0.15
A2	0.80	1.00	1.05
b	0.19	-	0.30
c	0.09	-	0.20
D	4.90	5.00	5.10
E	-	6.40 BSC	-
E1	4.30	4.40	4.50
e	-	0.65 BSC	-
L	0.45	0.60	0.75
L1	-	1.00 REF	-

Symbol	Min	Nom	Max
R	0.09	-	-
R1	0.09	-	-
S	0.20	-	-
θ1	0°	-	8°
θ2	-	12 REF	-
θ3	-	12 REF	-
aaa	-	0.10	-
bbb	-	0.10	-
ccc	-	0.05	-
ddd	-	0.20	-
N	16		



Marking: YYWWMZZ.

YY	WW	M	ZZ	@
Year (i.e. 10 for 2010)	Manufacturing Week	Assembly plant identifier	Assembly traceability code	Sublot identifier



The product is available in a 16LD QFN (4x4) package.

Figure 23. Drawings and Dimensions

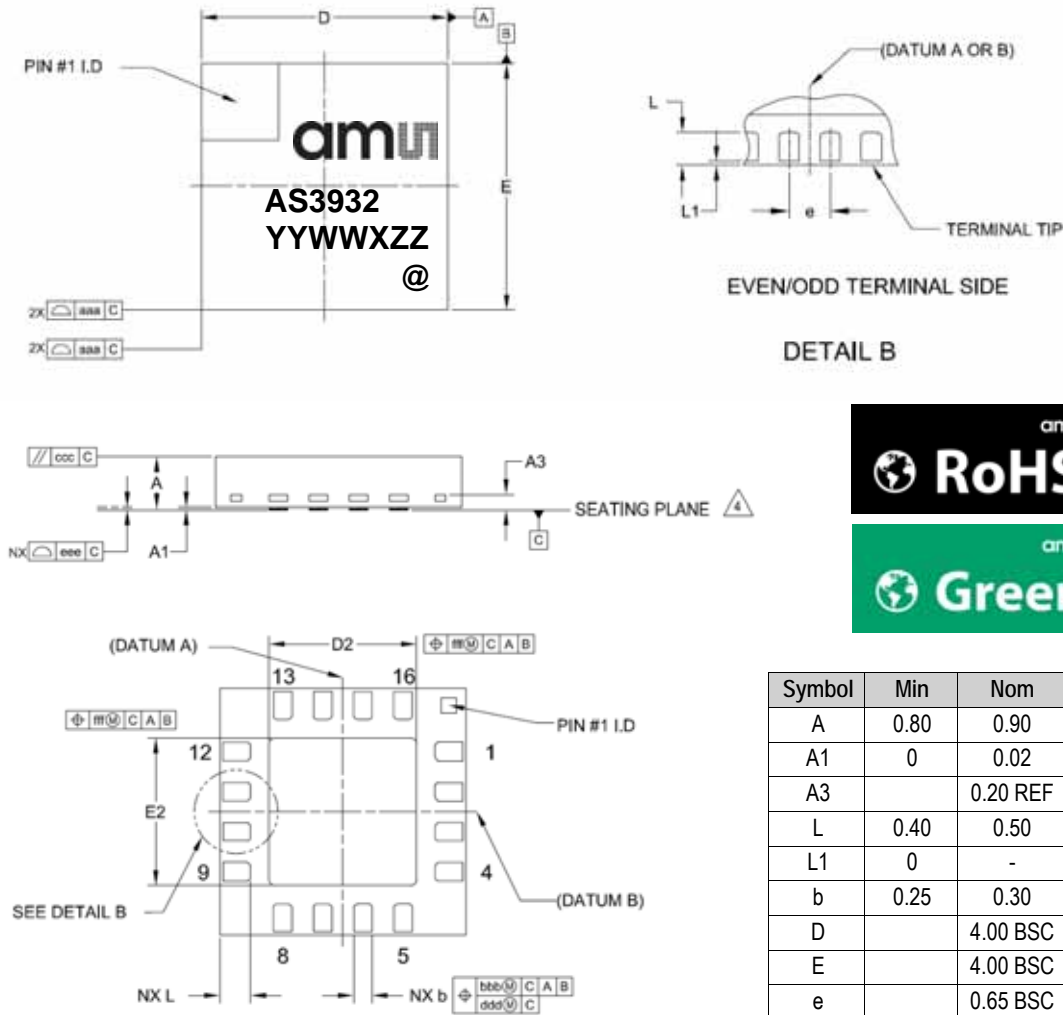

Symbol	Min	Nom	Max
A	0.80	0.90	1.00
A1	0	0.02	0.05
A3		0.20 REF	
L	0.40	0.50	0.60
L1	0	-	0.15
b	0.25	0.30	0.35
D		4.00 BSC	
E		4.00 BSC	
e		0.65 BSC	
D2	2.30	2.40	2.50
E2	2.30	2.40	2.50
aaa	-	0.15	-
bbb	-	0.10	-
ccc	-	0.10	-
ddd	-	0.05	-
eee	-	0.08	-
fff	-	0.10	-
N		16	

Notes:

1. Dimensions and tolerancing conform to *ASME Y14.5M-1994*.
2. All dimensions are in millimeters. Angles are in degrees.
3. Dimension b applies to metallized terminal and is measured between 0.25mm and 0.30mm from terminal tip. Dimension L1 represents terminal full back from package edge up to 0.15mm is acceptable.
4. Coplanarity applies to the exposed heat slug as well as the terminal.
5. Radius on terminal is optional.
6. N is the total number of terminals.

Marking: YYWWXZZ.

YY	WW	X	ZZ	@
Year (i.e. 10 for 2010)	Manufacturing Week	Assembly plant identifier	Assembly traceability code	Sublot identifier



Revision History

Table 26. Revision History

Revision	Date	Owner	Description
1.0	Feb 12, 2009	esn	
1.0a	Feb 24, 2009		Table 27 (Ordering information), -Z removed from part numbers
1.1	Apr 2, 2009		New figure inserted Figure 2 on page 2 , all subsequent chapters and page numbers are therefore incremented by one
			Default Values of Registers Table 7 , default value of R4<3:0> corrected
			Bit Setting of Gain Reduction Table 15 , stepsize of gain reduction increased to -4dBm
1.11	Apr 22, 2009		Description of external components on page 12 updated
1.12	May 25, 2009		Update of Section 10 Ordering Information on page 33
1.13	Jul 13, 2009		Updated Wake-up Protocol - Carrier Frequency 125 kHz 8.6 and description of Section 8.8.2 RC-Oscillator on page 28
1.2	Oct 13, 2009	mrh	Updated Key Features for External Clock
			Added Figure 3 AS3932 Typical Application Diagram with Clock from External Source
			Added External Clock Source in Electrical System Specifications Table 5
			Deleted table Minimum duration of carrier burst in ON/OFF mode (Manchester decoder enabled)
			Updated Real Time Clock (RTC) 8.8 with External Clock
1.3	Mar 25, 2010		Added External Clock Source 8.8.3
			Added a new section SDI Timing 8.2.4
			Updated R11 and R12 in Table 7
			Updated clock frequency of SDI to 2MHz in Serial Data Interface (SDI) 8.2.3
1.4	Sep 21, 2010		Updated time constant of RC filter in External Clock Source 8.8.3
			Updated Figure 19 and Figure 8.7
			Updated General Description , Key Features , Figure 1 , Figure 2 , Figure 3 , Figure 4 , Table 1 , Figure 5 , Table 2 , Figure 10 , Section 8.1.4 , Table 6 , Table 7 , Section 8.1.4 , Section 8.6.1 , Figure 19 , Section 8.6.2 , Package Drawings and Markings .
1.5	Mar 04, 2011	rtc	Deleted figure "Synchronization of Data with Recovered Manchester Clock" and chapter on "Single Pattern Detection (Manchester decoder enabled)"
	Mar 17, 2011		Updated Absolute Maximum Ratings
1.6	Jun 14, 2011		Deleted max value for IPWD parameter
1.7	Feb 04, 2012	jry	Corrected data inconsistencies across the datasheet.
	Jun 18, 2013		Corrected package drawings in Figure 23 on page 31 .

Note: Typos may not be explicitly mentioned under revision history.



10 Ordering Information

The devices are available as the standard products shown in [Table 27](#).

Table 27. Ordering Information

Ordering Code	Type	Marking	Delivery Form ¹	Delivery Quantity
AS3932-BTST	16-pin TSSOP	AS3932	7 inches Tape & Reel	1000 pcs
AS3932-BQFT	16LD QFN (4x4)	AS3932	7 inches Tape & Reel	1000 pcs

1. Dry Pack Sensitivity Level =3 according to IPC/JEDEC J-STD-033A for full reels.

Note: All products are RoHS compliant and ams green.
Buy our products or get free samples online at www.ams.com/ICdirect

Technical Support is available at www.ams.com/Technical-Support

For further information and requests, email us at sales@ams.com
(or) find your local distributor at www.ams.com/distributor



Copyrights

Copyright © 1997-2013, ams AG, Tobelbaderstrasse 30, 8141 Unterpremstaetten, Austria-Europe. Trademarks Registered ®. All rights reserved. The material herein may not be reproduced, adapted, merged, translated, stored, or used without the prior written consent of the copyright owner.

All products and companies mentioned are trademarks or registered trademarks of their respective companies.

Disclaimer

Devices sold by ams AG are covered by the warranty and patent indemnification provisions appearing in its Term of Sale. ams AG makes no warranty, express, statutory, implied, or by description regarding the information set forth herein or regarding the freedom of the described devices from patent infringement. ams AG reserves the right to change specifications and prices at any time and without notice. Therefore, prior to designing this product into a system, it is necessary to check with ams AG for current information. This product is intended for use in normal commercial applications. Applications requiring extended temperature range, unusual environmental requirements, or high reliability applications, such as military, medical life-support or life-sustaining equipment are specifically not recommended without additional processing by ams AG for each application. For shipments of less than 100 parts the manufacturing flow might show deviations from the standard production flow, such as test flow or test location.

The information furnished here by ams AG is believed to be correct and accurate. However, ams AG shall not be liable to recipient or any third party for any damages, including but not limited to personal injury, property damage, loss of profits, loss of use, interruption of business or indirect, special, incidental or consequential damages, of any kind, in connection with or arising out of the furnishing, performance or use of the technical data herein. No obligation or liability to recipient or any third party shall arise or flow out of ams AG rendering of technical or other services.



Contact Information

Headquarters

ams AG
Tobelbaderstrasse 30
A-8141 Unterpremstaetten, Austria

Tel : +43 (0) 3136 500 0
Fax : +43 (0) 3136 525 01

For Sales Offices, Distributors and Representatives, please visit:

<http://www.ams.com/contact>

Mouser Electronics

Authorized Distributor

Click to View Pricing, Inventory, Delivery & Lifecycle Information:

[ams:](#)

[AS3932-BQFT](#)