

SPECIFICATIONS

| PARAMETERS | VALUES | UNITS |
|------------------------------|---------|-------|
| DIRECTIVITY | OMNI | - |
| SENSITIVITY | -44 ± 3 | dB |
| STANDARD OPERATING VOLTAGE | 1.5 | Vdc |
| MAX OPERATING VOLTAGE | 10 | Vdc |
| CURRENT CONSUMPTION (MAX) | 0.5 | mA |
| IMPEDANCE | 2.2 | KOhm |
| SIGNAL TO NOISE RATIO (MIN.) | 60 | dB |
| TERMINAL | PIN | - |
| INTERNAL CAPACITOR | N/A | pF |

THIS DOCUMENT CONTAINS DATA PROPRIETARY TO PROJECTS UNLIMITED, INC. ANY USE OR REPRODUCTION, IN ANY FORM, WITHOUT PRIOR WRITTEN PERMISSION OF PROJECTS UNLIMITED, INC. IS PROHIBITED.
©2003, Projects Unlimited Inc.

REVISION HISTORY

| LTR | DESCRIPTION | DATE | APPROVED |
|-----|--|-----------|----------|
| - | RELEASED FROM ENGINEERING | 1/30/2006 | |
| A | REVISED TO INVENTOR 3-D DRAWING TEMPLATE | 9/8/2010 | B.R. |
| B | ADDED PIN DIMENSIONS | 11/8/2010 | C.W. |

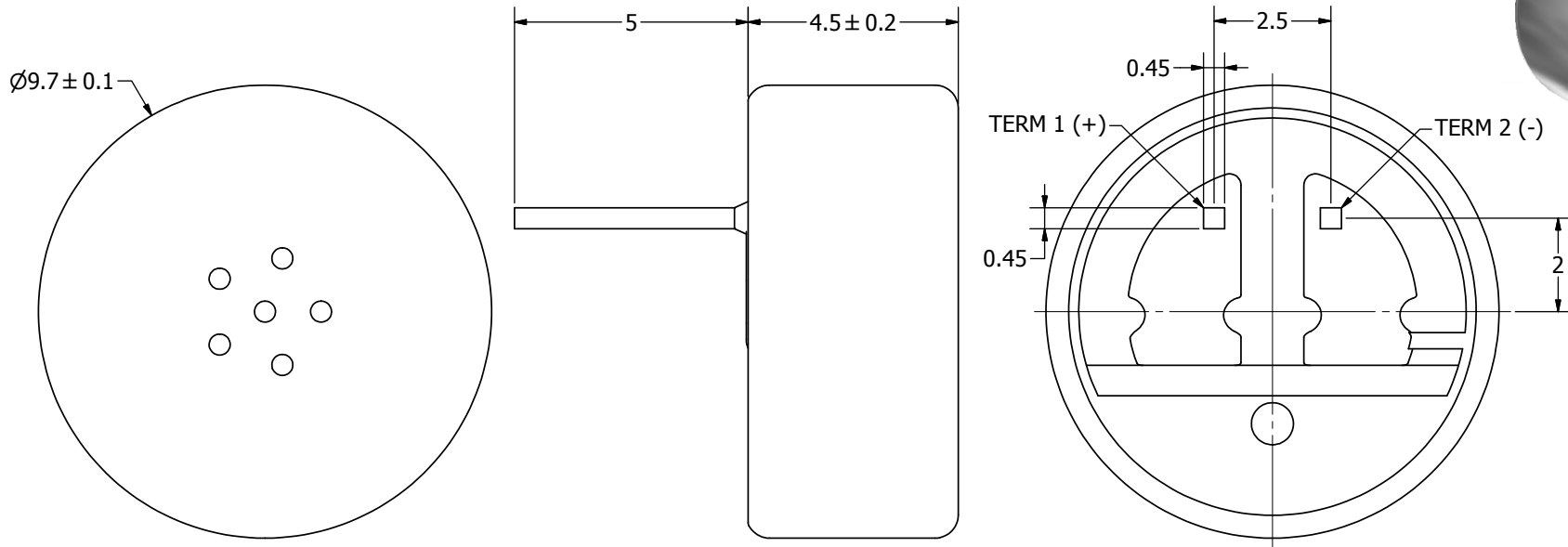
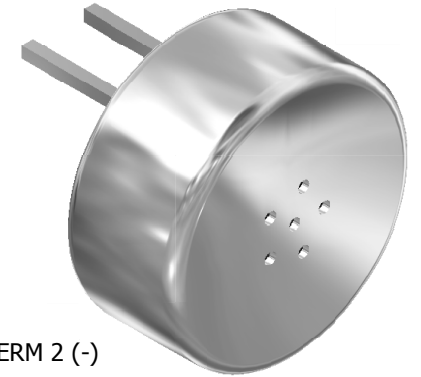

NOTES:

1. ALL DIMENSIONS ARE IN MILLIMETERS.
2. SPECIFICATIONS SUBJECT TO CHANGE OR WITHDRAWAL WITHOUT NOTICE.
3. THIS PART IS RoHS 2002/95/EC COMPLIANT.

| | | | | | | | | | |
|--|------|-------------|-----------|----------------|-----------|-------------|------------|------------|--------------------------------|
| UNLESS OTHERWISE SPECIFIED: DIMENSIONS ARE IN MILLIMETERS, TOLERANCES ARE ±0.5 AND ANGLES ARE ±3°. | SIZE | Designed by | Date | Checked by | Date | Approved by | Date | Drawn Date | |
| | A3 | J.A.F. | 1/30/2006 | E.P. | 1/30/2006 | B.R. | 1/30/2006 | 9/8/2010 | |
| AOM-4544P-NF-R.idw | | | | AOM-4544P-NF-R | | | Microphone | | Edition - Sheet 1 / 1 |

Mouser Electronics

Authorized Distributor

Click to View Pricing, Inventory, Delivery & Lifecycle Information:

[PUI Audio:](#)

[AOM-4544P-NF-R](#)