



LPR2430ER

- **2.4 GHz Spread Spectrum Transceiver Module**
- **Small Size, Light Weight, +18 dBm Transmitter Power**
- **Sleep Current less than 3 μ A**
- **FCC, Canadian IC and ETSI Certified for Unlicensed Operation**

High Power 802.15.4 Module

The LPR2430ER 2.4 GHz transceiver module is a low cost, high-power solution for peer-to-peer, point-to-point and point-to-multipoint wireless designs. LPR2430ER modules provide the flexibility and versatility to serve applications ranging from cable replacements to sensor networks. Based on the IEEE 802.15.4 wireless standard, the LPR2430ER module is easy to integrate and provides robust wireless communications in applications where full mesh network operation is not required. The LPR2430ER includes CNL V2.0 Network Layer firmware which features a flexible and simple-to-use Application Programming Interface.



Shown with Shield Removed

LPR2430ER Absolute Maximum Ratings

Rating	Value	Units
All Input/Output Pins	-0.3 to +3.6	V
Non-Operating Ambient Temperature Range	-40 to +85	$^{\circ}$ C

LPR2430ER Electrical Characteristics

Characteristic	Sym	Notes	Minimum	Typical	Maximum	Units
Operating Frequency Range			2405		2475	MHz
Operating Frequency Tolerance			-300		300	kHz
Spread Spectrum Method			Direct Sequence			
Modulation Type			O-QPSK			
Number of RF Channels				15		
RF Data Transmission Rate				250		kb/s
Symbol Rate Tolerance					120	ppm
RF Channel Spacing				5		MHz
Receiver Sensitivity, 10E-5 BER				-95		dBm
Upper Adjacent Channel Rejection, +5 MHz				41		dB
Lower Adjacent Channel Rejection, -5 MHz				30		dB
Upper Alternate Channel Rejection, +10 MHz				55		dB
Lower Alternate Channel Rejection, -10 MHz				53		dB
Maximum RF Transmit Power				18		dBm
Transmit Power Adjustment					20	dB
Optimum Antenna Impedance				50		Ω

LPR2430ER Electrical Characteristics

Characteristic	Sym	Notes	Minimum	Typical	Maximum	Units
ADC Input Range			0		3.3	V
ADC Input Resolution				11		bits
ADC Input Impedance			55			MΩ
PWM Output Resolution*			8		16	bits
UART Baud Rate			1.2, 2.4, 4.8, 9.6 (default), 19.2, 28.8, 38.4, 57.6, 76.8, 115.2			kb/s
Digital I/O:						
Logic Low Input Level			-0.3		0.5	V
Logic High Input Level			2.8		3.3	V
Logic Input Internal Pull-up Resistor			20			KΩ
GPIO3 Logic Low Sink Current					20	mA
Power Supply Voltage Range	V _{CC}		+3.3		+5.5	Vdc
Power Supply Voltage Ripple					10	mV _{P-P}
Receive Mode Current				33		mA
Transmit Mode Current				130		mA
Sleep Mode Current					3	μA
Operating Temperature Range			-40		85	°C

*PWM0 has 8-bit resolution, PWM1 has 16-bit resolution. Built-in PWM output filters suppress ripple to 7 bits. Additional filtering can be added externally.



CAUTION: Electrostatic Sensitive Device. Observe precautions when handling.

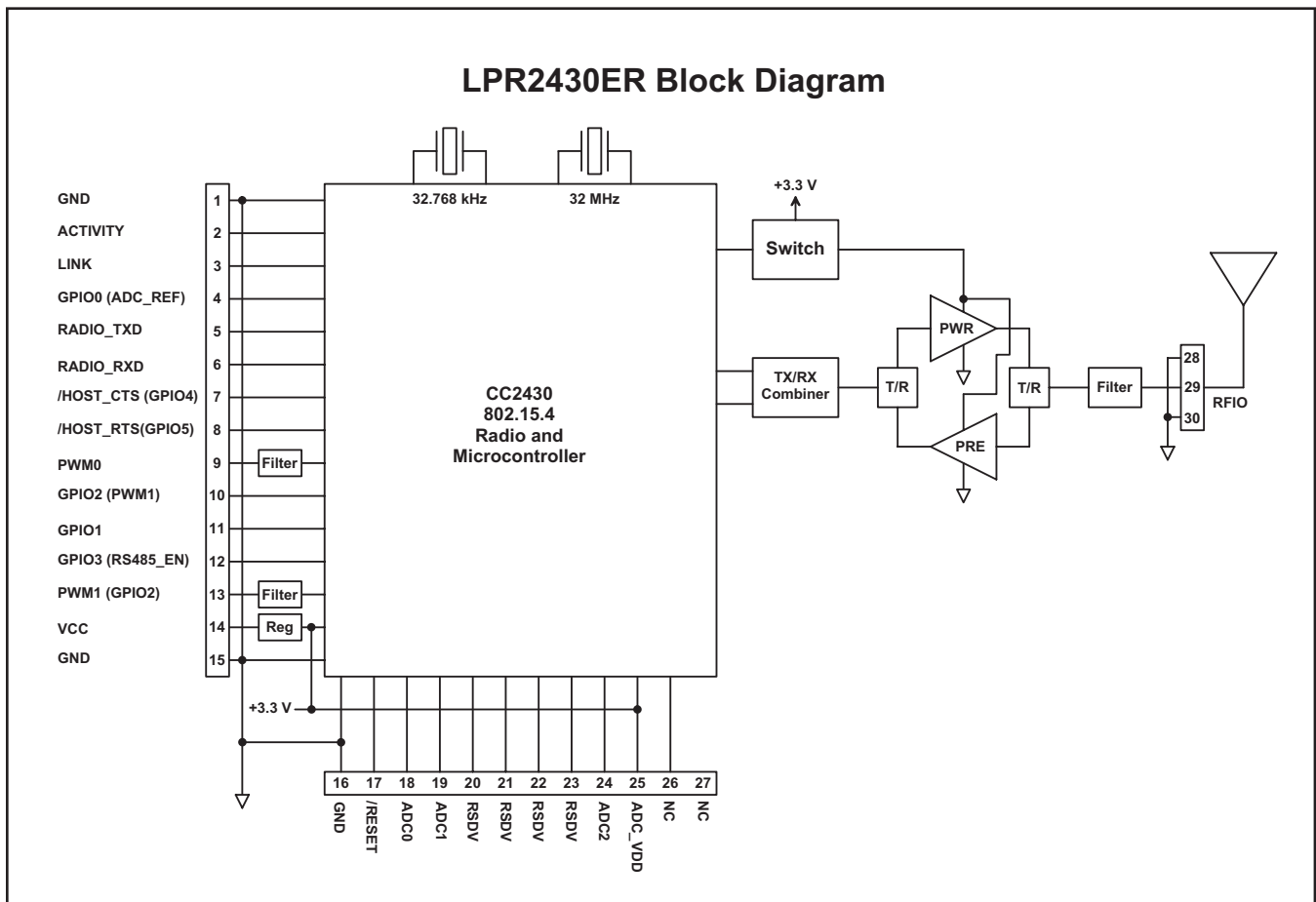

Figure 1

LPR2430ER Hardware

The major hardware component of the LPR2430ER is the CC2430 IEEE 802.15.4 compatible transceiver with integrated 8051 microcontroller. The LPR2430ER operates in the frequency band of 2405 to 2475 MHz at a nominal output power of 63 mW.

The LPR2430ER includes a low noise preamplifier in the receiver path and a power amplifier in the transmitter path, greatly increasing the operating range of the CC2430. Two crystals are provided to operate the CC2430, a 32 MHz crystal for normal operation and a 32.768 kHz crystal for precision sleep mode operation.

The LPR2430ER provides a variety of application hardware interfaces including a UART interface, three 11-bit ADC inputs, two PWM (DAC) outputs, and six general purpose digital I/O ports.

LPR2430ER Firmware

The main firmware components in the LPR2430ER include the 802.15.4 Media Access Control (MAC) layer and the CNL V2.0 Networking Layer. CNL V2.0 supports up to 63 remotes. Network topologies include point-to-point, point-to-multipoint and peer-to-peer. CNL employs one-hop relay forwarding to mitigate network transmission problems such as multipath fading. CNL includes provisions for low-power sleep mode operation with periodic wakeup and report. The CNL Application Programming Interface (API) provides an easy-to-use, flexible set of application commands and functions. The API includes support for send/receive serial data, read/write GPIO, read ADC inputs, write PWM outputs and module configuration services. In addition, CNL supports analog and digital I/O binding, which maps an ADC measurement and the states of two digital inputs on one LPR2430ER to a PWM output and two digital outputs on another LPR2430ER. See the *LPR2430 Series Integration Guide* for complete details of the CNL API.

LPR2430ER I/O Pad Descriptions

Pin	Name	I/O	Description
1	GND	-	Power supply and signal ground. Connect to the host circuit board ground.
2	ACTIVITY	O	RF activity indicator. Output pulses high when a packet is sent or received.
3	LINK	O	Link indicator. Output is high when the radio has successfully joined a network.
4	GPIO0 (ADC_REF)	I/O	Configurable digital I/O port 0. When configured as an output, the power-on state is also configurable. This pin can also be configured as a reference voltage input for the ADCs, 0 to 3.3 V, 1.25 V typical.
5	RADIO_TXD	O	Serial data output (UART) from the radio to the host.
6	RADIO_RXD	I	Serial data input (UART) from the host to the radio.
7	GPIO4 (/HOST_CTS)	I/O	Configurable digital I/O port 4. When configured as an output, the power-on state is also configurable. Also configurable as UART flow control output. The LPR2430 sets this line low to indicate it is ready to accept data from the host on the RADIO_RXD input. When the LPR2430 sets this line high, the host must stop sending data. The default state is GPIO4.
8	GPIO5 (/HOST_RTS)	I/O	Configurable digital I/O port 5. When configured as an output, the power-on state is also configurable. Also configurable as UART flow control input. The host sets this line low to allow data to flow from the RADIO_TXD pin. When the host sets this line high, the LPR2430 will stop sending data to the host. The default state is GPIO5.
9	PWM0	O	Pulse-width modulated output 0 with internal low-pass filter. Provides a DAC function, 0 to 3.3 V.
10	GPIO2 (PWM1)	I/O	Configurable digital I/O port 2. When configured as an output, the power-on state is also configurable. This pin is connected to the input of the low-pass filter driving Pin 13, and is also configurable as a PWM output.
11	GPIO1	I/O	Configurable digital I/O port 1. When configured as an output, the power-on state is also configurable.
12	GPIO3 (RS485_EN)	I/O	Configurable digital I/O port 3. When configured as an output, this high current port can sink up to 20 mA. The power-on output state is also configurable. Can also be configured as active low transmit enable for controlling an RS485 or other half-duplex bus driver.
13	PWM1 (GPIO2)	O	GPIO2 (Pin 10) drives this pin through a low-pass filter. Provides a DAC function when GPIO2 is configured as a PWM output.
14	VCC	I	Power supply input, +3.3 to +5.5 Vdc.
15	GND	-	Power supply and signal grounds. Connect to the host circuit board ground.
16	GND	-	Power supply and signal grounds. Connect to the host circuit board ground.
17	/RESET	I	Active low module hardware reset. Hold this input low when the power supply input is less than 3.3 Vdc. The module firmware boots up and will accept commands about 3 seconds after this input goes high.
18	ADC0	I	11-bit ADC input 0. ADC full scale reading can be referenced to the module's +3.3 V regulated supply, the ADC's internal +2.5 V reference, or ADC_REF (Pin 4).
19	ADC1	I	ADC input 1. Same configuration options as ADC0.
20	RSVD	-	Reserved pin. Leave unconnected.
21	RSVD	-	Reserved pin. Leave unconnected.
22	RSVD	-	Reserved pin. Leave unconnected.
23	RSVD	-	Reserved pin. Leave unconnected.
24	ADC2	I	ADC input 2. Same configuration options as ADC0.
25	ADC_VDD	O	Module's +3.3 V regulated supply, used for ratiometric ADC readings. Current drain should be less than 5 mA.
26	NC	-	No connection.
27	NC	-	No connection.
28	GND	-	RF ground. Connect to the host circuit board ground plane, and to shield when using coaxial cable.
29	RFIO	I/O	RF port. Connect the antenna to this port with a 50 Ω stripline or semi-rigid coaxial cable.
30	GND	-	RF ground. Connect to the host circuit board ground plane, and to shield when using coaxial cable.

LPR2430ER Outline and Mounting Dimensions

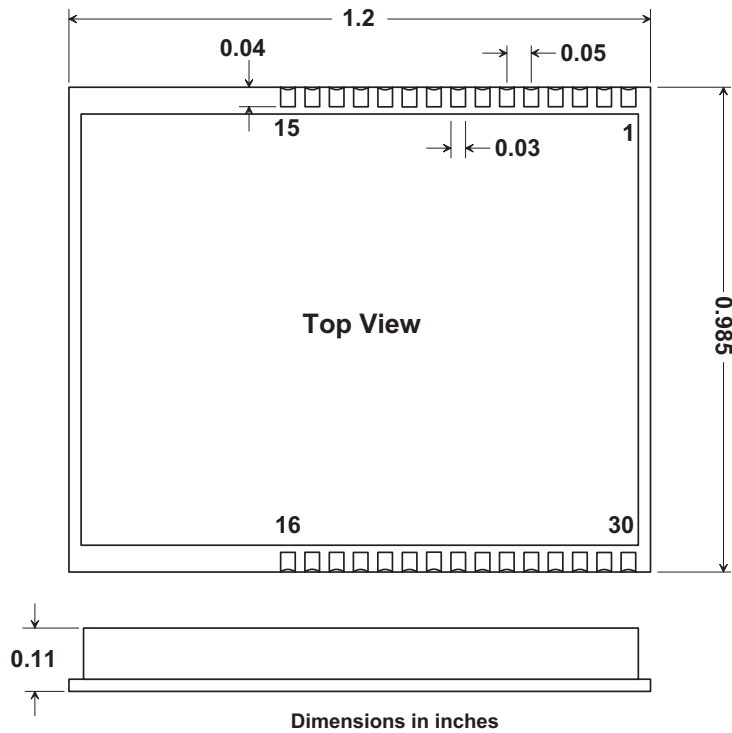

Figure 2

RFIO Stripline

The RFIO pad on the radio module is connected directly to an antenna on the host circuit board, or to an MMCX or similar RF connector. It is important that this connection be implemented as a 50 ohm stripline. Referring to Figure 3, the width of this stripline depends on the thickness of the circuit board between the stripline and the groundplane. For FR-4 type circuit board materials (dielectric constant of 4.7), the width of the stripline is equal to 1.75 times the thickness of the circuit board. Note that other circuit board traces should be spaced away from the stripline to prevent signal coupling, as shown in Figure 4. The stripline trace should be kept short to minimize its insertion loss.

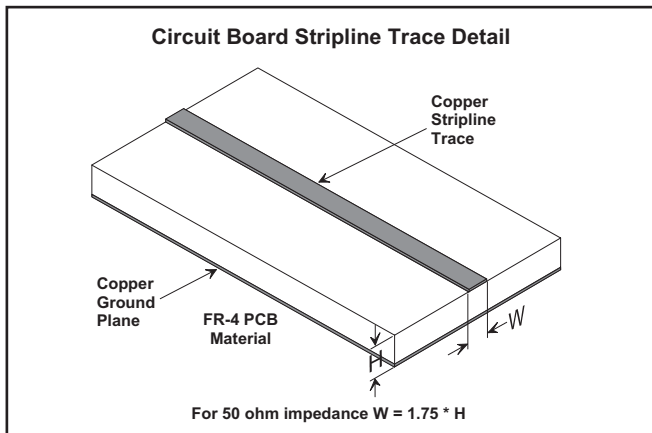

Figure 3

Trace Separation from 50 Ohm Microstrip	Length of Trace Run Parallel to Microstrip
100 mil	125 mil
150 mil	200 mil
200 mil	290 mil
250 mil	450 mil
300 mil	650 mil

Figure 4

Reflow Profile

An example solder reflow profile for mounting the radio module on its host circuit board is shown in Figure 5.

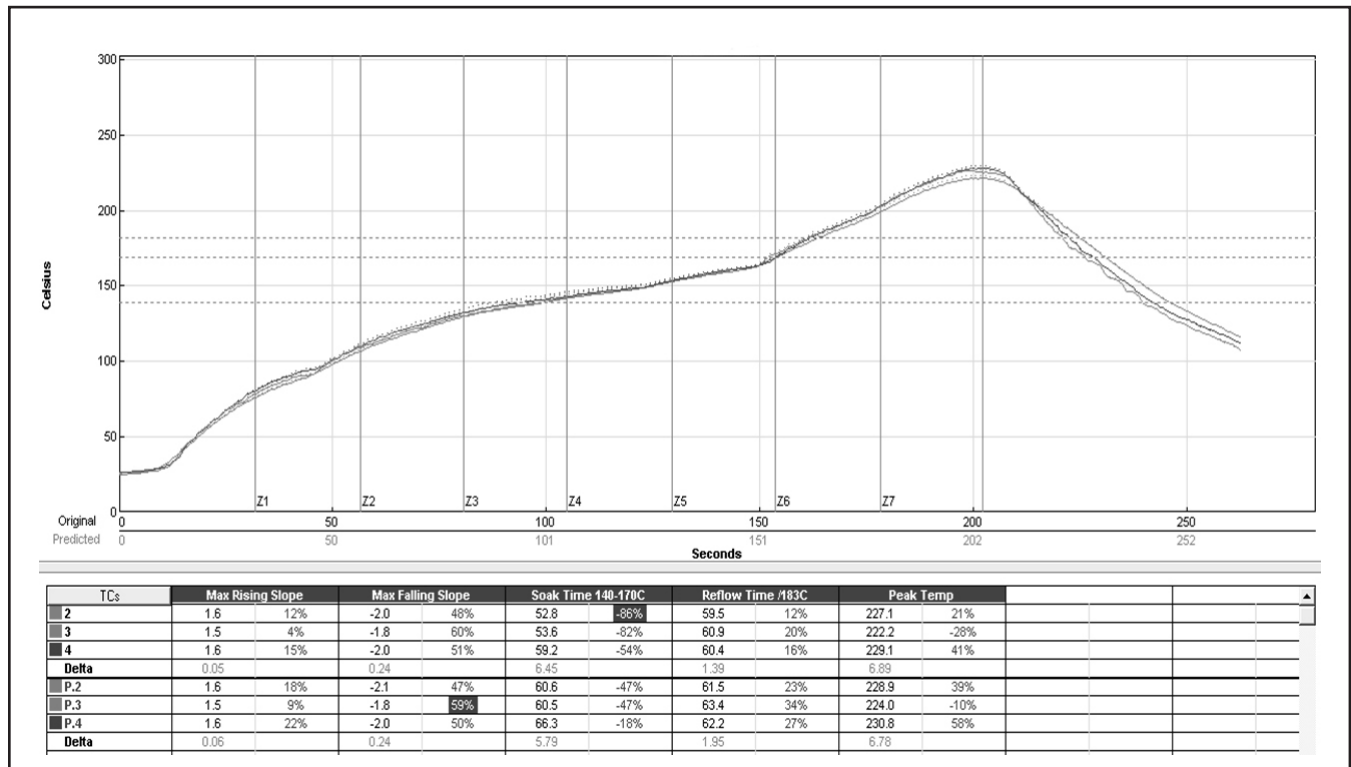

Figure 5

Note: Specifications subject to change without notice.

Part # M-2430-0004, Rev A