

## OXU810DSE, Dual Drive NAS System Device with Encryption

### Highlights

#### General Features

- Seamless interface to two integrated SATA ports, expandable via PCI SATA bridge chips

#### Key Features

- Seamless interface to two integrated SATA ports, expandable via PCI SATA bridge chips
- Accessible from multiple clients using Ethernet (integrated 10/100/1000 Ethernet MAC) with MII and GMII support, or IEEE 802.11 Wi-Fi (via PCI interface)
- 367 MHz ARM926EJ-S processor with 32 Kbyte caches & MMU
- TSO (TCP/IP segmentation offload)
- Supports multiple software architectures
  - Linux OS
  - TCP/IP & CIFS
  - EXT3
  - XFS
- RAID 1 hardware accelerator
- Simple to install - no specialist user knowledge necessary; automatic installation with DHCP client & simple configuration
- Integrated fan tachometer/thermistor controller and pulse width modulators
- Integrated hardware 128-bit AES encryption/decryption engine
- 5 channel DMA controller
- USB 2.0 & USB full-speed host controllers
- 128 Kbyte on-chip SRAM
- DDR1/2 SDRAM controller 16 bit interface supports combinations up to 256 Mbytes addressable storage
- 16 bit static memory interface (optional - device boots from HDD) supports up to 4 Mbytes addressable storage per chip-select
- 35 GPIO for easy customization



The OXE810DSE is a consumer network-attached storage (NAS) device and is the successor to the OXE800DSE. It delivers a wide array of consumer specific applications such as media server and automatic backup combined with easy-to-use software making it ideal for mainstream consumers who need to store and share their digital information. The device supports two hard disks in a RAID 1 configuration.

The OXE810DSE has an outstanding price/performance ratio with a high level of integration and includes advanced encryption capabilities in hardware. It offers diverse connectivity including 10/100/1000 Ethernet plus CIFS over TCIP/IP, XFS and EXT3.

This adaptable and highly-configurable device also supports connections to IEEE 802.11 and other standard wireless chips via Mini PCI. It provides two integrated SATA port, a USB high-speed port and two USB full-speed host ports supporting additional expansion capability via USB HDDs.

### Embedded ARM Processor

An integrated ARM926EJ-S processor @367MHz, featuring an MMU and 32 Kbyte caches, runs Linux OS with a full network stack. For system control, there is an integrated fan tachometer/thermistor controller and pulse width modulators. Used in conjunction, these facilities can optionally trigger and modulate a fan or initiate protective measures.

### SATA Interface

The embedded 3GHz SATA host interfaces supports the latest revisions of the SATA II specifications. Interface speeds of 3GHz and 1.5GHz deliver maximum performance with minimum latency for external SATA storage.

### RAID

The RAID controller supports mirroring (RAID 1) providing the highest level of data integrity with 100% data redundancy, disk spanning (concatenation) presenting all drives as a single large volume, or two independent disk configurations.

### USB Multi-Port Host Controller

The USB can be used to connect to external USB HDDs via the high-speed 480-Mbps port A, or to other peripherals, such as printers or USB memory via the full-speed 12-Mbps ports B and C as well as port A. The controller has its own DMA engine to collect and store packets either in internal SRAM or external SDRAM.

### Static RAM Controller

The static memory controller can interface to any static memory type device. In addition to static RAM, it can also interface to intelligent LCD controllers and NOR flash.

## OXU810DSE, Dual Drive NAS System Device with Encryption

### PCI Controller

The PCI core can be configured as a host or device under software control. It can be used to communicate with planar PCI devices or mini-PCI cards such as SATA controllers and 802.11 wireless LAN controllers. In PCI host mode the controller can support up to 4 external devices on the bus.

### Development Tools and Custom Solutions

For external Mac and PC storage solutions, Oxford Semiconductor offers a comprehensive support package including:

- Reference designs comprising both hardware and software components
- Evaluation boards
- Software Development Kit (SDK) comprising source code and debug boards
- Extensive range of application notes

### OXE810DSE Block Diagram

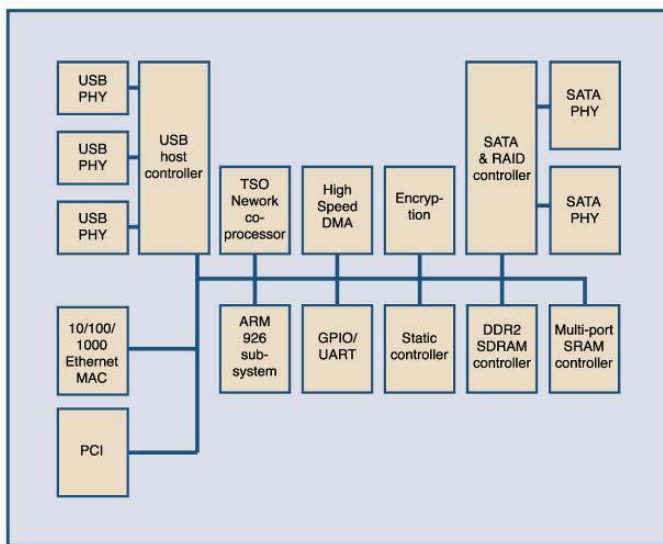

**OXE810DSE**

### Product Ordering Information

Part Number	Description
OXU810DSE-PBAG	Dual Drive NAS System Device with Encryption

PLX Technology, Inc. All rights reserved. PLX and the PLX logo are trademarks of PLX Technology, Inc. All other product names that appear in this material are for identification purposes only and are acknowledged to be trademarks or registered trademarks of their respective companies. Information supplied by PLX is believed to be accurate and reliable, but PLX assumes no responsibility for any errors that may appear in this material. PLX reserves the right, without notice, to make changes in product design or specification.

Visit [www.plxtech.com](http://www.plxtech.com) for more information.