

REV. A	AUTH. R.L.	DATE 10/11/02	INITIAL RELEASE	APPROVED
REV. B	AUTH. R.L.	DATE 5/20/04	CORRECTED HD'WARE NOTES, DIMS	APPROVED

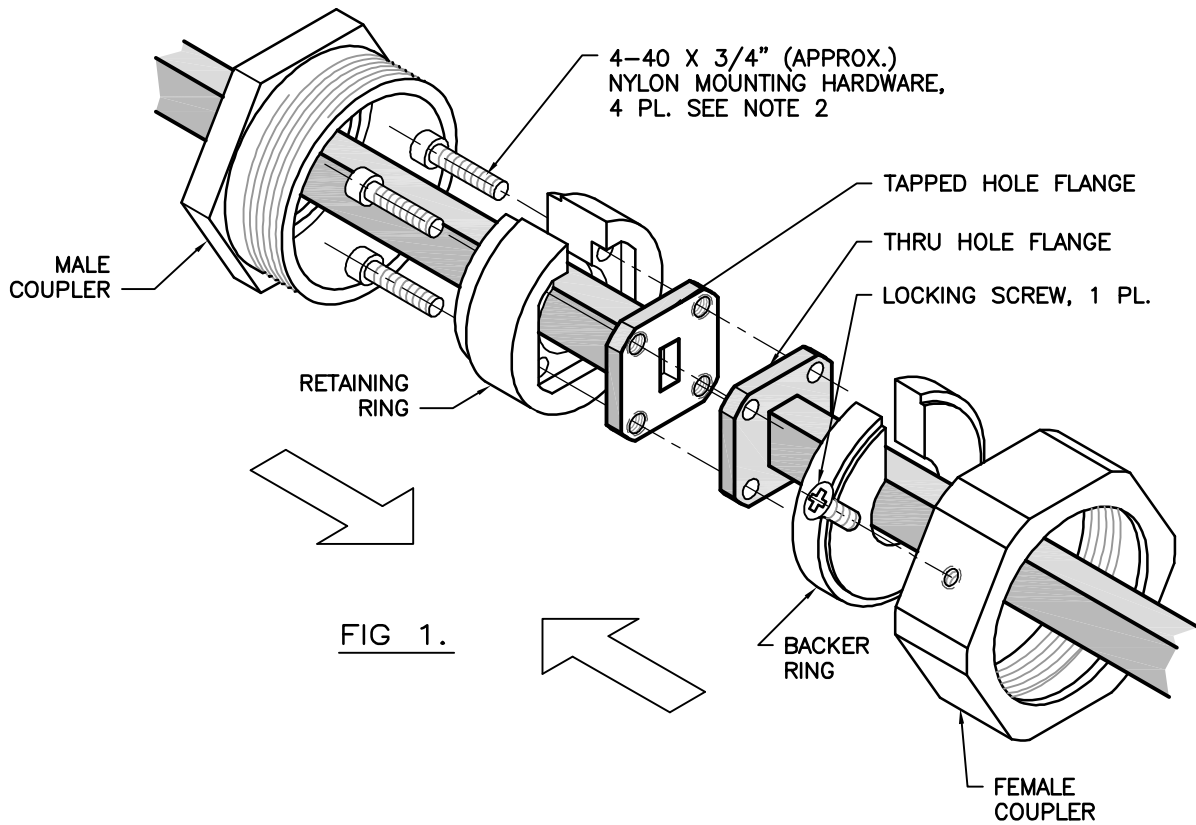

FIG. 1.

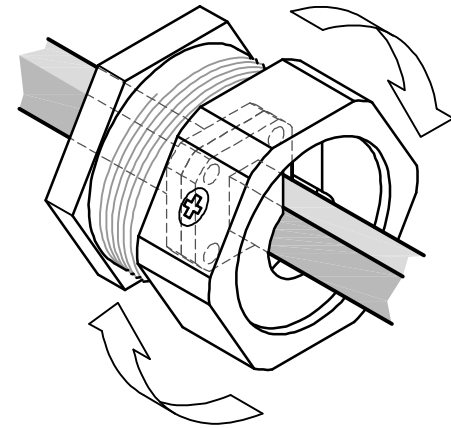
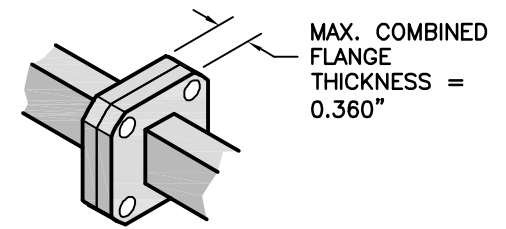

FIG. 2.



DETAIL A

MAX. COMBINED FLANGE THICKNESS = 0.360"

ASSEMBLY:

1. TIGHTEN LOCKING SCREWS: MALE GETS FASTENED TO RETAINING RING, FEMALE COUPLER GETS FASTENED TO BACKER RING.
2. THREAD NYLON HARDWARE THROUGH RETAINING RING, INTO TAPPED HOLE FLANGE. **NOTE:** CUT HARDWARE TO LENGTH, SO AS NOT TO PROTRUDE THROUGH BACK OF THRU HOLE FLANGE.
3. MATE TAPPED HOLE & THRU HOLE FLANGES.
4. JOIN TOGETHER MALE & FEMALE COUPLERS AND SCREW TIGHT.

MATERIAL -	TREATMENT -	DRAWN R. LYNCH	DATE 10/11/02
FINISH -	MOD NO. QD28/34/42	CHECKED	DATE
ASSEMBLY, WR28/42/34 QUICK DISCONNECT		APPROVED	DATE
		CAGE CODE: OR8N4	DO NOT SCALE DWG
ADVANCED TECHNICAL MATERIALS, INC. 49 RIDER AVE., PATCHOGUE N.Y. 11772 TEL: (631) 289-0386 FAX: (631) 289-0358 http://www.atmmicrowave.com		UNLESS OTHERWISE NOTED DIMENSIONS ARE IN INCHES TOLERANCES ARE:	FRACTIONS ±1/64 DECIMALS ±.01 ANGLES ±1/2°
		SCALE NONE	DWG. NO. 3398
<small>PROPRIETARY NOTICE: THE INFORMATION IN THIS DRAWING IS PROPRIETARY AND SHALL NOT BE USED OR DISCLOSED WITHOUT THE PRIOR WRITTEN CONSENT OF ATM, INC.</small>			SHEET. 1/1 REV. B