



**Synchronous DRAM Module 128Mbyte(16Mx64-Bit), 144pin SO-DIMM,  
4Banks, 4K Ref., 3.3V**

**Part No.**

## GENERAL DESCRIPTION

The HSD16M64B8W is a 16M x 64 bit Synchronous Dynamic RAM high density memory module. The module consists of eight CMOS 2M x 16 bit x 4banks Synchronous DRAMs in TSOP-II 400mil packages on a 144-pin glass-epoxy substrate. Two 0.1uF decoupling capacitors are mounted on the printed circuit board in parallel for each SDRAM. The HSD16M64B8W is a SO-DIMM(Small Outline Dual in line Memory Module) and is intended for mounting into 144-pin edge connector sockets. Synchronous design allows precise cycle control with the use of system clock. I/O transactions are possible on every clock cycle. Range of operating frequencies, programmable latencies allows the same device to be useful for a variety of high bandwidth, high performance memory system applications All module components may be powered from a single 3.3V DC power supply and all inputs and outputs are LVTTTL-compatible.

## FEATURES

- Part Identification
  - HSD16M64B8W-10 : 100MHz (CL=2)
  - HSD16M64B8W-10L : 100MHz (CL=3)
  - HSD16M64B8W-12 : 125MHz (CL=3)
  - HSD16M64B8W-13 : 133MHz (CL=3)
  
- Burst mode operation
- Auto & self refresh capability (4096 Cycles/64ms)
- LVTTTL compatible inputs and outputs
- Single 3.3V  $\pm$ 0.3V power supply
  
- MRS cycle with address key programs
  - Latency (Access from column address)
  - Burst length (1, 2, 4, 8 & Full page)
  - Data scramble (Sequential & Interleave)
  
- All inputs are sampled at the positive going edge of the system clock
- The used device is 2M x 16bit x 4Banks SDRAM

## PIN ASSIGNMENT

PIN	Front	PIN	Back	PIN	Frontl	PIN	Back	PIN	Front	PIN	Back
1	Vss	2	Vss	49	DQ13	50	DQ45	97	DQ22	98	DQ54
3	DQ0	4	DQ32	51	DQ14	52	DQ46	99	DQ23	100	DQ55
5	DQ1	6	DQ33	53	DQ15	54	DQ47	101	VCC	102	VCC
7	DQ2	8	DQ34	55	Vss	56	Vss	103	A6	104	A7
9	DQ3	10	DQ35	57	NC	58	NC	105	A8	106	BA0
11	VCC	12	VCC	59	NC	60	NC	107	Vss	108	Vss
13	DQ4	14	DQ36	61	CLK0	62	CKE0	109	A9	110	BA1
15	DQ4	16	DQ37	63	VCC	64	VCC	111	A10_AP	112	A11
17	DQ6	18	DQ38	65	/RAS	66	/CAS	113	VCC	114	VCC
19	DQ7	20	DQ39	67	/WE	68	CKE1	115	DQM2	116	DQM6
21	Vss	22	Vss	69	/CS0	70	NC(A12)	117	DQM3	118	DQM7
23	DQM0	24	DQM4	71	/CS1	72	NC	119	Vss	120	Vss
25	DQM1	26	DQM5	73	NC	74	CLK1	121	DQ24	122	DQ56
27	VCC	28	VCC	75	Vss	76	Vss	123	DQ25	124	DQ57
29	A0	30	A3	77	NC	78	NC	125	DQ26	126	DQ58
31	A1	32	A4	79	NC	80	NC	127	DQ27	128	DQ59
33	A2	34	A5	81	VCC	82	VCC	129	VCC	130	VCC
35	Vss	36	Vss	83	DQ16	84	DQ48	131	DQ28	132	DQ60
37	DQ8	38	DQ40	85	DQ17	86	DQ49	133	DQ29	134	DQ61
39	DQ9	40	DQ41	87	DQ18	88	DQ50	135	DQ30	136	DQ62
41	DQ10	42	DQ42	89	DQ19	90	DQ51	137	DQ31	138	DQ63
43	DQ11	44	DQ43	91	Vss	92	Vss	139	Vss	140	Vss
45	VCC	46	VCC	93	DQ20	94	DQ52	141	SDA	142	SCL
47	DQ12	48	DQ44	95	DQ21	96	DQ53	143	VCC	144	VCC

## \*Pin Names

Pin Name	Function	Pin Name	Function
A0 ~ A11	Address input (Multiplexed)	BA0 ~ BA1	Select bank
DQ0 ~ DQ63	Data input/output	CLK0,CLK1	Clock input
CKE0, CKE1	Clock enable input	/CS0, /CS1	Chip select input
/RAS	Row address strobe	/CAS	Column address strobe
/WE	Write enable	DQM0 ~ 7	DQM
Vcc	Power supply (3.3V)	Vss	Ground
SDA	Serial data I/O	SCL	Serial clock
NC	No connection		

FUNCTIONAL BLOCK DIAGRAM

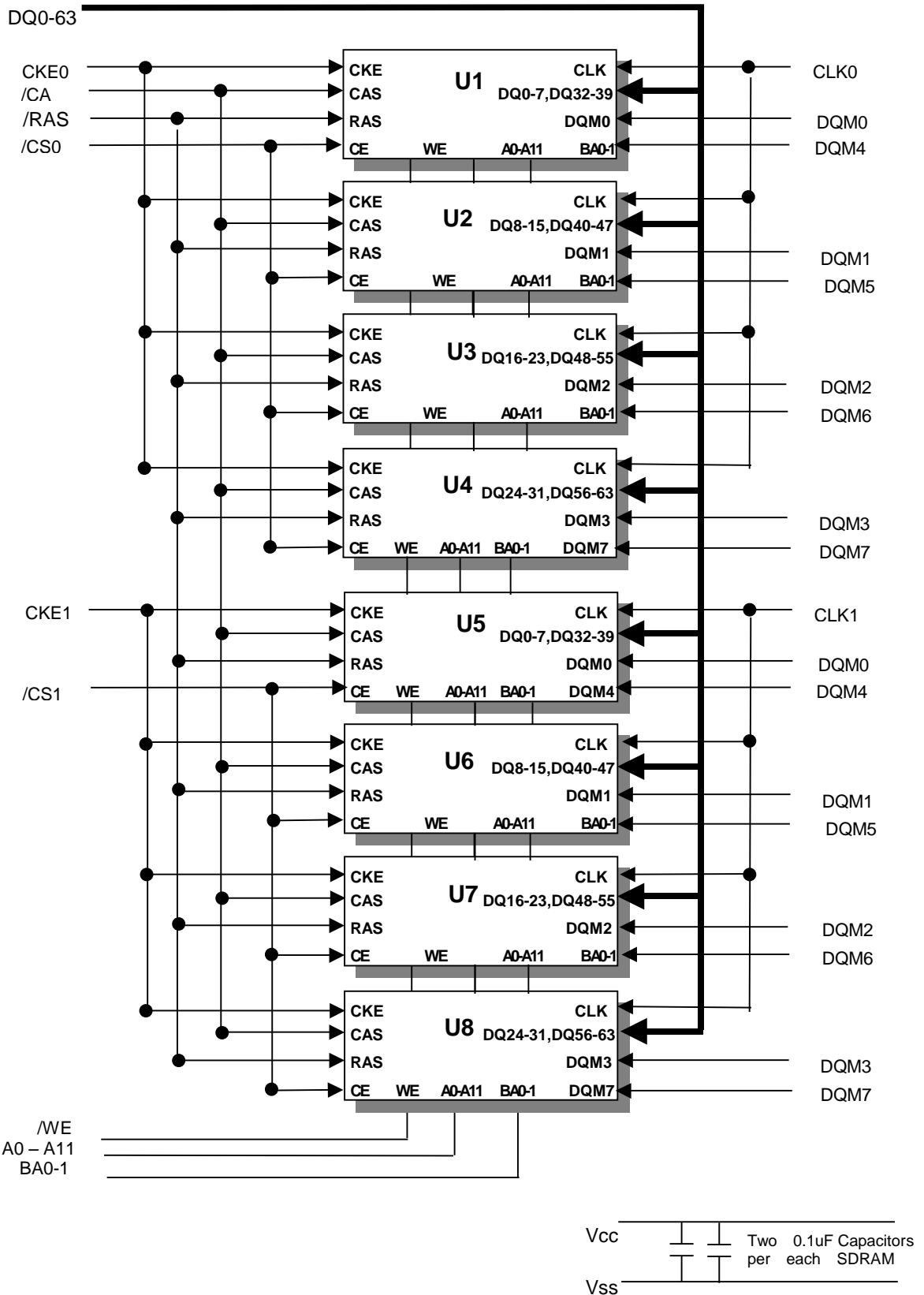

**PIN FUNCTION DESCRIPTION**

PIN	NAME	INPUT FUNCTION
CLK	System clock	Active on the positive going edge to sample all inputs.
/CS	Chip enable	Disables or enables device operation by masking or enabling all inputs except CLK, CKE and DQM
CKE	Clock enable	Masks system clock to freeze operation from the next clock cycle. CKE should be enabled at least one cycle prior to new command. Disable input buffers for power down in standby. CKE should be enabled 1CLK+tSS prior to valid command.
A0 ~ A11	Address	Row/column addresses are multiplexed on the same pins. Row address : RA0 ~ RA11, Column address : CA0 ~ CA8
BA0 ~ BA1	Bank select address	Selects bank to be activated during row address latch time. Selects bank for read/write during column address latch time.
/RAS	Row address strobe	Latches row addresses on the positive going edge of the CLK with RAS low. Enables row access & precharge.
/CAS	Column address strobe	Latches column addresses on the positive going edge of the CLK with CAS low. Enables column access.
/WE	Write enable	Enables write operation and row precharge. Latches data in starting from CAS, WE active.
DQM0 ~ 7	Data input/output mask	Makes data output Hi-Z, tSHZ after the clock and masks the output. Blocks data input when DQM active. (Byte masking)
DQ0 ~DQ63	Data input/output	Data inputs/outputs are multiplexed on the same pins.
VCC/VSS	Power supply/ground	Power and ground for the input buffers and the core logic.

**ABSOLUTE MAXIMUM RATINGS**

PARAMETER	SYMBOL	RATING
Voltage on Any Pin Relative to Vss	V <sub>IN,OUT</sub>	-1V to 4.6V
Voltage on Vcc Supply Relative to Vss	V <sub>CC</sub>	-1V to 4.6V
Power Dissipation	P <sub>D</sub>	8W
Storage Temperature	T <sub>STG</sub>	-55°C to 150°C
Short Circuit Output Current	I <sub>OS</sub>	400mA

**Notes:**

Permanent device damage may occur if " Absolute Maximum Ratings" are exceeded. Functional operation should be restricted to the conditions as detailed in the operational sections of this data sheet. Exposure to absolute maximum rating conditions for extended periods may affect device reliability.

## DC OPERATING CONDITIONS

(Recommended operating conditions (Voltage referenced to VSS = 0V, TA = 0 to 70°C) )

PARAMETER	SYMBOL	MIN	TYP.	MAX	UNIT	NOTE
Supply Voltage	V <sub>CC</sub>	3.0	3.3	3.6	V	
Input High Voltage	V <sub>IH</sub>	2.0	3.0	V <sub>CC</sub> +0.3	V	1
Input Low Voltage	V <sub>IL</sub>	-0.3	0	0.8	V	2
Output High Voltage	V <sub>OH</sub>	2.4	-	-	V	I <sub>OH</sub> = -2mA
Output Low Voltage	V <sub>OL</sub>	-	-	0.4	V	I <sub>OL</sub> = 2mA
Input leakage current	I <sub>LI</sub>	-12	-	12	uA	3

### Notes :

- V<sub>IH</sub> (max) = 5.6V AC. The overshoot voltage duration is ≤ 3ns.
- V<sub>IL</sub> (min) = -2.0V AC. The undershoot voltage duration is ≤ 3ns.
- Any input 0V ≤ V<sub>IN</sub> ≤ V<sub>DDQ</sub>.  
Input leakage currents include Hi-Z output leakage for all bi-directional buffers with Tri-State outputs.

## CAPACITANCE

(VCC = 3.3V, TA = 23°C, f = 1MHz, VREF = 1.4V ± 200 mV)

DESCRIPTION	SYMBOL	MIN	MAX	UNITS
Clock	C <sub>CLK</sub>	20	32	pF
/RAS, /CAS, /WE, /CS, CKE, DQM	C <sub>IN</sub>	20	40	pF
Address	C <sub>ADD</sub>	20	40	pF
DQ (DQ0 ~ DQ63)	C <sub>OUT</sub>	32	52	pF

## DC CHARACTERISTICS

(Recommended operating condition unless otherwise noted, TA = 0 to 70°C)

PARAMETER	SYMBOL	TEST CONDITION	VERSION				UNIT	NOTE
			-13	-12	-10	-10L		
Operating current (One bank active)	I <sub>CC1</sub>	Burst length = 1 t <sub>RC</sub> ≥ t <sub>RC</sub> (min) I <sub>O</sub> = 0mA	120 0	120 0	1120	112 0	mA	1
Precharge standby current in power-down mode	I <sub>CC2P</sub>	CKE ≤ V <sub>IL</sub> (max) t <sub>CC</sub> =10ns	8				mA	
	I <sub>CC2PS</sub>	CKE & CLK ≤ V <sub>IL</sub> (max) t <sub>CC</sub> =∞	8				mA	
Precharge standby current in non power-down mode	I <sub>CC2N</sub>	CKE ≥ V <sub>IH</sub> (min) CS* ( V <sub>IH</sub> (min), t <sub>CC</sub> =10ns Input signals are changed one time during 20ns	160				mA	

	ICC2NS	CKE ( VIH(min) CLK $\leq$ V <sub>IL</sub> (max), t <sub>CC</sub> = $\infty$ Input signals are stable	56					
Active standby current in power-down mode	I <sub>CC3P</sub>	CKE $\leq$ V <sub>IL</sub> (max), t <sub>CC</sub> =10ns	40				mA	
	I <sub>CC3PS</sub>	CKE&CLK $\leq$ V <sub>IL</sub> (max) t <sub>CC</sub> = $\infty$	40					
Active standby current in non power-down mode (One bank active)	I <sub>CC3N</sub>	CKE $\geq$ V <sub>IH</sub> (min), CS* $\geq$ V <sub>IH</sub> (min), t <sub>CC</sub> =10ns Input signals are changed one time during 20ns	240				mA	
	I <sub>CC3NS</sub>	CKE $\geq$ V <sub>IH</sub> (min) CLK $\leq$ V <sub>IL</sub> (max), t <sub>CC</sub> = $\infty$ Input signals are stable	120					
Operating current (Burst mode)	I <sub>CC4</sub>	I <sub>o</sub> = 0 mA Page burst 4Banks Activated t <sub>CCD</sub> = 2CLKs	144 0	136 0	1160	116 0	mA	1
Refresh current	I <sub>CC5</sub>	t <sub>RC</sub> $\geq$ t <sub>RC</sub> (min)	176 0	176 0	1680	168 0		
Self refresh current	I <sub>CC6</sub>	CKE $\leq$ 0.2V	12				mA	
			6.4					

**Notes :**

1. Measured with outputs open.
2. Refresh period is 64ms.
3. Unless otherwise noticed, input swing level is CMOS(V<sub>IH</sub>/V<sub>IL</sub>=V<sub>DDQ</sub>/V<sub>SSQ</sub>).

**AC OPERATING TEST CONDITIONS**(v<sub>cc</sub> = 3.3V  $\pm$  0.3V, TA = 0 to 70°C)

PARAMETER	Value	UNIT
AC Input levels (V <sub>ih</sub> /V <sub>il</sub> )	2.4/0.4	V
Input timing measurement reference level	1.4	V
Input rise and fall time	tr/tf = 1/1	Ns
Output timing measurement reference level	1.4	V
Output load condition	See Fig. 2	

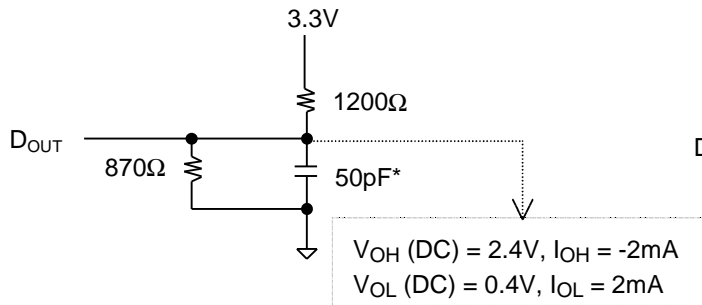

(Fig. 1) DC output load

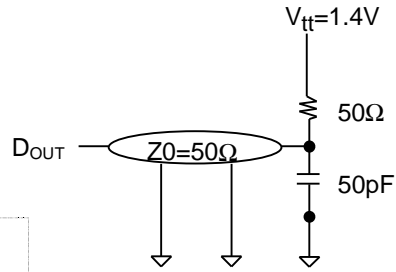

(Fig. 2) AC output load circuit

**OPERATING AC PARAMETER**

(AC operating conditions unless otherwise noted)

PARAMETER	SYMBOL	VERSION				UNIT	NOTE
		-13	-12	-10	-10L		
Row active to row active delay	$t_{RRD}(\min)$	15	16	20	20	ns	1
RAS to CAS delay	$t_{RP}(\min)$	20	20	20	20	ns	1
Row precharge time	$t_{RP}(\min)$	20	20	20	20	ns	1
Row active time	$t_{RAS}(\min)$	45	48	50	50	ns	1
	$t_{RAS}(\max)$	100				ns	
Row cycle time	$t_{RC}(\min)$	65	68	70	70	ns	1
Last data in to row precharge	$t_{RDL}(\min)$	2				CLK	2.5
Last data in to Active delay	$t_{DAL}(\min)$	2 CLK + 20 ns					
Last data in to new col. address delay	$t_{CDL}(\min)$	1				CLK	2
Last data in to burst stop	$t_{BDL}(\min)$	1				CLK	2
Col. address to col. address delay	$t_{CCD}(\min)$	1				CLK	3
Number of valid output data	CAS latency=3	2				ea	4
	CAS latency=2	-		1			

**Notes :**

1. The minimum number of clock cycles is determined by dividing the minimum time required with clock cycle time and then rounding off to the next higher integer.
2. Minimum delay is required to complete write.
3. All parts allow every cycle column address change.
4. In case of row precharge interrupt, auto precharge and read burst stop.

## AC CHARACTERISTICS

(AC operating conditions unless otherwise noted)

PARAMETER		SYMBOL	-13		-12		-10		-10L		UNIT	NOTE
			MIN	MAX	MIN	MAX	MIN	MAX	MIN	MAX		
CLK cycle time	CAS latency=3	t <sub>CC</sub>	7.5	1000	8	1000	10	1000	10	1000	ns	1
	CAS latency=2		-		-		10		12			
CLK to valid output delay	CAS latency=3	t <sub>SAC</sub>		5.4		6		6		6	ns	1,2
	CAS latency=2			-		-		6		7		
Output data hold time	CAS latency=3	t <sub>OH</sub>	2.7		3		3		3		ns	2
	CAS latency=2		-		-		3		3			
CLK high pulse width		t <sub>CH</sub>	2.5		3		3		3		ns	3
CLK low pulse width		t <sub>CL</sub>	2.5		3		3		3		ns	3
Input setup time		t <sub>SS</sub>	1.5		2		2		2		ns	3
Input hold time		t <sub>SH</sub>	0.8		1		1		1		ns	3
CLK to output in Low-Z		t <sub>SLZ</sub>	1		1		1		1		ns	3
CLK to output in Hi-Z	CAS latency=3	t <sub>SHZ</sub>		5.4		6		6		6	ns	2
	CAS latency=2			-		-		6		7	ns	

**Notes :**

- Parameters depend on programmed CAS latency.
- If clock rising time is longer than 1ns, (tr/2-0.5)ns should be added to the parameter.
- Assumed input rise and fall time (tr & tf) = 1ns.  
If tr & tf is longer than 1ns, transient time compensation should be considered, ie., [(tr + tf)/2-1]ns should be added to the parameter.



## SIMPLIFIED TRUTH TABLE

COMMAND		CKE n-1	CKE n	/C S	/R A S	/C A S	/W E	D Q M	BA 0,1	A10/ AP	A11 A9~A0	NOT E	
Register	Mode register set	H	X	L	L	L	L	X	OP code			1,2	
Refresh	Auto refresh		H	H	L	L	L	H	X	X		3	
	Self refresh	Entry		L								3	
		Exit	H	L	H	H	H	X	X		3		
	H			X	X	X	3						
Bank active & row addr.		H	X	L	L	H	H	X	V	Row address			
Read & column address	Auto precharge disable		H	X	L	H	L	H	X	V	L	Column Address (A0 ~ A8)	4
	Auto precharge disable										H		4,5
Write & column address	Auto precharge disable		H	X	L	H	L	L	X	V	L	Column Address (A0 ~ A8)	4
	Auto precharge disable										H		4,5
Burst Stop		H	X	L	L	H	L	X	X			6	
Precharge	Bank selection		H	X	L	L	H	L	X	V	L	X	
	All banks									X	H		
Clock suspend or active power down	Entry		H	L	H	X	X	X	X	X			
	Exit				L	H	X	X					X
Precharge power down mode	Entry		H	L	H	X	X	X	X	X			
					L	H	H	H					
	Exit		L	H	H	X	X	X	X				
					L	V	V	V					
DQM		H	X					V	X			7	
No operation command		H	X	H	X	X	X	X	X				
				L	H	H	H						

(V=Valid, X=Don't care, H=Logic high, L=Logic low)

**Notes :**

- OP Code : Operand code  
A0 ~ A11 & BA0 ~ BA1 : Program keys. (@ MRS)
- MRS can be issued only at all banks precharge state.  
A new command can be issued after 2 CLK cycles of MRS.
- Auto refresh functions are as same as CBR refresh of DRAM.  
The automatical precharge without row precharge command is meant by "Auto".  
Auto/self refresh can be issued only at all banks precharge state.
- BA0 ~ BA1 : Bank select addresses.  
If both BA0 and BA1 are "Low" at read, write, row active and precharge, bank A is selected.  
If both BA0 is "Low" and BA1 is "High" at read, write, row active and precharge, bank B is selected.  
If both BA0 is "High" and BA1 is "Low" at read, write, row active and precharge, bank C is selected.  
If both BA0 and BA1 are "High" at read, write, row active and precharge, bank D is selected.  
If A10/AP is "High" at row precharge, BA0 and BA1 is ignored and all banks are selected.
- During burst read or write with auto precharge, new read/write command can not be issued.  
Another bank read/write command can be issued after the end of burst.  
New row active of the associated bank can be issued at tRP after the end of burst.
- Burst stop command is valid at every burst length.
- DQM sampled at positive going edge of a CLK and masks the data-in at the very CLK (Write DQM latency is 0), but makes Hi-Z state the data-out of 2 CLK cycles after. (Read DQM latency is 2)

**TIMING DIAGRAMS**

Please refer to attached timing diagram chart (II)

**PACKAGING INFORMATION**

Unit : Inch [mm]

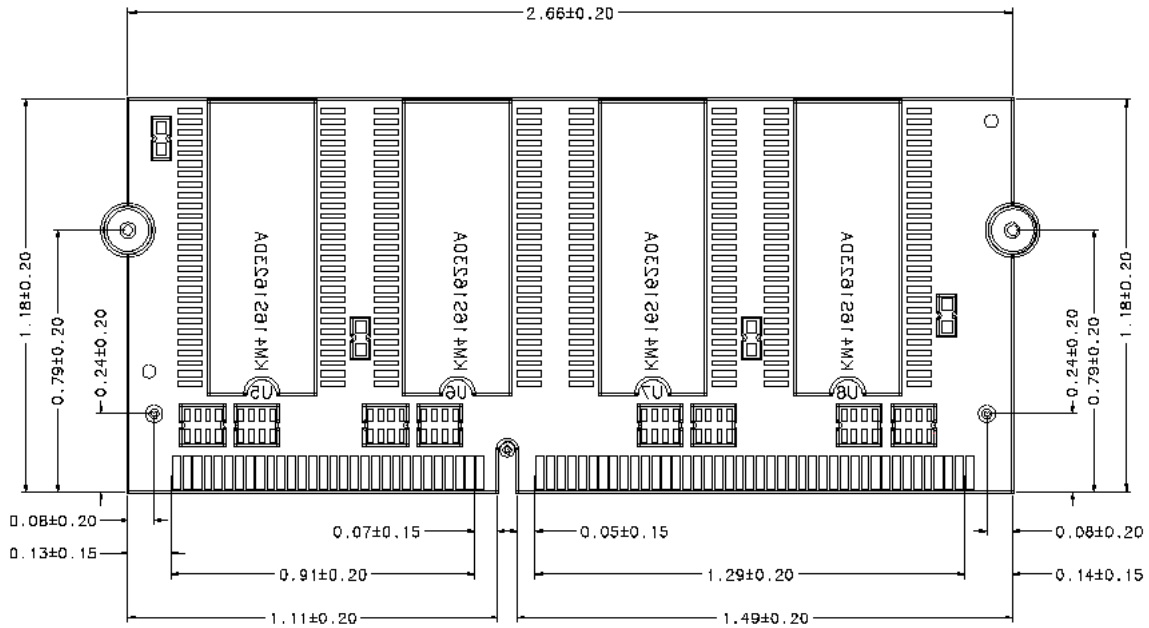

PCB Thickness: 1.0mm (0.9.t - 1.1t)

Immersion Gold PCB Pattern

**ORDERING INFORMATION**

Part Number	Density	Org.	Package	Ref.	Vcc	MODE	MAX.frq
HSD16M64B8W-10	128MByte	16M x 64	144 Pin-SODIMM	4K	3.3V	SDRAM	CL2 100MHz
HSD16M64B8W-10L	128MByte	16M x 64	144 Pin-SODIMM	4K	3.3V	SDRAM	CL3 100MHz
HSD16M64B8W-12	128MByte	16M x 64	144 Pin-SODIMM	4K	3.3V	SDRAM	CL3 125MHz
HSD16M64B8W-13	128MByte	16M x 64	144 Pin-SODIMM	4K	3.3V	SDRAM	CL 3 133MHz