

Commercial Miniature 5/8" (16mm) Diameter Composition Variable Resistors

- Miniature 5/8" (16mm) size
- Versatile mounting styles:
 - bushing
 - twist tab
 - bend tab
 - snap-in PC bracket
 - solder lug or PC terminals
(shaft parallel or perpendicular to the panel)
- 100 Ω to 5 Meg Ω resistance range
- Molded or metal shafts
- SPST power switches
- Single, tandem, or concentric units
- Panel seal
- Rear extended shaft

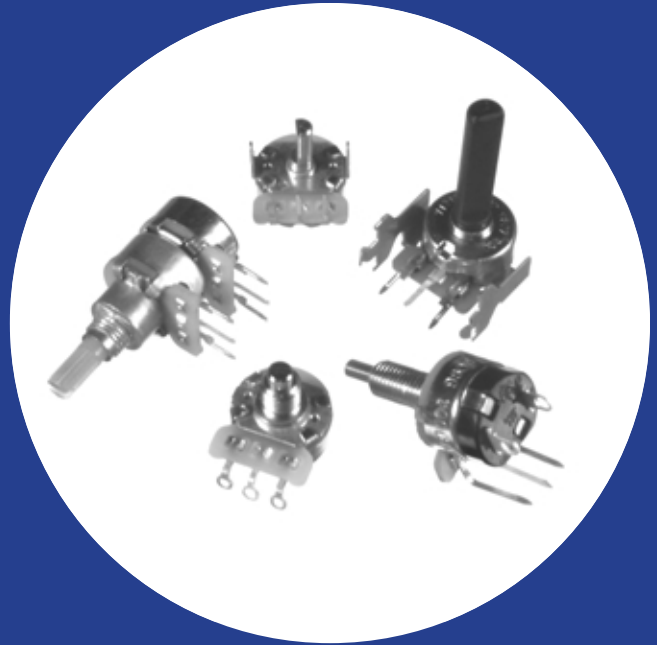

Electrical and Mechanical Specifications

Resistance Range

100 Ω through 5 Meg Ω (linear taper).

Resistance Tolerance

Standard: $\pm 20\%$

Special: Other tolerances available in most resistance values.

Power Rating, Watts

$\frac{1}{4}$ watt per section through 100K

$\frac{1}{5}$ watt per section above 100K

Full rating @ 55°C derated to no load at 85°C,
linear taper, bushing mounted control on steel panel
4" x 4" x .050" (101.6mm x 101.6mm x 1.27mm).
(Derating required on two section controls.)

Voltage Rating

Bushings to Terminals:

High pot test, one minute — 750 VAC

Operating maximum — 500 VDC

Across End Terminals:

350 VDC, load not to exceed listed wattage ratings.

Resistance Tapers

Standard: Linear, 10% Audio and 10% CCW Audio
Special tapers available to meet most requirements

Angle of Rotation

Total Rotation

Without Switch: $300^\circ \pm 5^\circ$

With Switch: $315^\circ \pm 5^\circ$

Effective Rotation

Without Switch: 300° (approximate)

With Switch: 290° (approximate)

Panel Mounting Information

Bushing Mount

Standard: Brass

(continued on next page)

Electrical and Mechanical Specifications (continued)

All Other Mounts

Standard: Twist tab (designated by "1")
 Special: Bend tab — 2 or 3 ears
 Bracket mounted

Suggested Panel for Twist Tab

.042" thick (1.07mm)

Locating Lugs (Bushing Mount)

Standard: .312" (7.9mm) radius from center of control.
 Special: .375" (9.53mm) radius from center of control.
 Standard Position: Left side supplied unless otherwise specified.
 Other Positions: Available with lug right side, without lugs, or with lugs both left and right sides.

Water Seal Construction

Controls are also available to prevent water from entering the control through either the O.D. of shaft and/or the bushing.

Shaft and Bushing Information

Bushing Lengths Available

Standard: .187" or .250" (4.75mm or 6.35mm)
 Special: .125" increments (3.2mm increments)

Thread Size

Standard: 1/4" – 32
 3/8" – 32
 M7 x .75
 M8 x .75P
 Special: As required

Molded Shafts Available

(Shown with preferred diameter bushing)

Bushing Mounted or Ear Mounted

| SHAFT DIAMETER | | BUSHING DIAMETER | |
|----------------|------|------------------|--------|
| INCH | MM | INCH | MM |
| .156 | 4.0 | 1/4" – 32 | M7X.75 |
| .187 | 4.7 | — | M7X.75 |
| .236 | 6.0 | 3/8" – 32 | M8X.75 |
| .250 | 6.35 | 3/8" – 32 | M9X.75 |

Metal Shafts Available

(Shown with preferred diameter bushing)

Single or Dual Units

| SHAFT DIAMETER | | BUSHING DIAMETER | |
|----------------|------|------------------|--------|
| INCH | MM | INCH | MM |
| .125 | 3.2 | 1/4" – 32 | M7X.75 |
| .156 | 4.0 | 1/4" – 32 | M7X.75 |
| .187 | 4.7 | 3/8" – 32 | M7X.75 |
| .236 | 6.0 | 3/8" – 32 | M8X.75 |
| .250 | 6.35 | 3/8" – 32 | M9X.75 |

Concentric Tandem Units

Available in two combinations:

A – .125" (3.2mm) diameter rear shaft
 .250" (6.35mm) panel shaft
 (3/8 – 32 or M9X.75)

B – .156" (4.0mm) diameter rear shaft
 .236" (6.0mm) diameter panel shaft
 (3/8 – 32 or M8X.75)

Most metal shaft diameters can be used with twist tab mountings. With bracket mount, only .187 diameter shafts are used, with turn-down available to obtain smaller diameters.

Metal

Lengths: Minimum .125" (3.2mm) beyond bushing; special lengths as required.
 Trims: Plain round screwdriver slotted, flatted, knurled. Other trims available upon request.

Molded

Flatted and knurled with screwdriver slot available in many lengths and diameters.

Terminal Information

Standard: T Solder lug formed 90° to the rear.
 Special: *(See below)*

- T: Solder lug perpendicular to shaft.
- T: Solder lug formed 60° to the rear.
- U: PC terminals formed 90° forward toward mounting surface. Terminals extend .187" (4.7mm) beyond mounting surface.
- V: PC terminals formed 90° to the rear, away from panel mounting. Terminals extend .520" (13.2mm) from mounting surface.
- W: Wire wrap terminals — .156" (4.0mm) terminal extension beyond base, formed 60° to the rear.
- BX: PC terminals standard .438" (11.1mm) from center line of control to PC board; straight terminals extend .156" (4.0mm) into PC board.
- X: PC terminals standard .505" (12.8mm) from center line of control to PC board, with .136" (3.4mm) straight terminal extension beyond PC board standoff.
- Y: PC terminals standard .602" (15.3mm) from centerline of control to PC board, with .140" (3.5mm) straight terminal extension beyond PC board standoff.

(continued on next page)

Electrical and Mechanical Specifications (continued)

Power Switches Available (all SPST)

| SERIES | TYPE | ELECTRICAL RATING |
|--------|--------|-------------------------------|
| 057 | Rotary | 5A @ 20 VDC |
| 057 | Rotary | 3A @ 125 VAC (UL approved) |

Switch Actuating Angle -25°
 Switch Actuating Torque - 2 to 10 in. oz.
 (144 to 720g-cm)

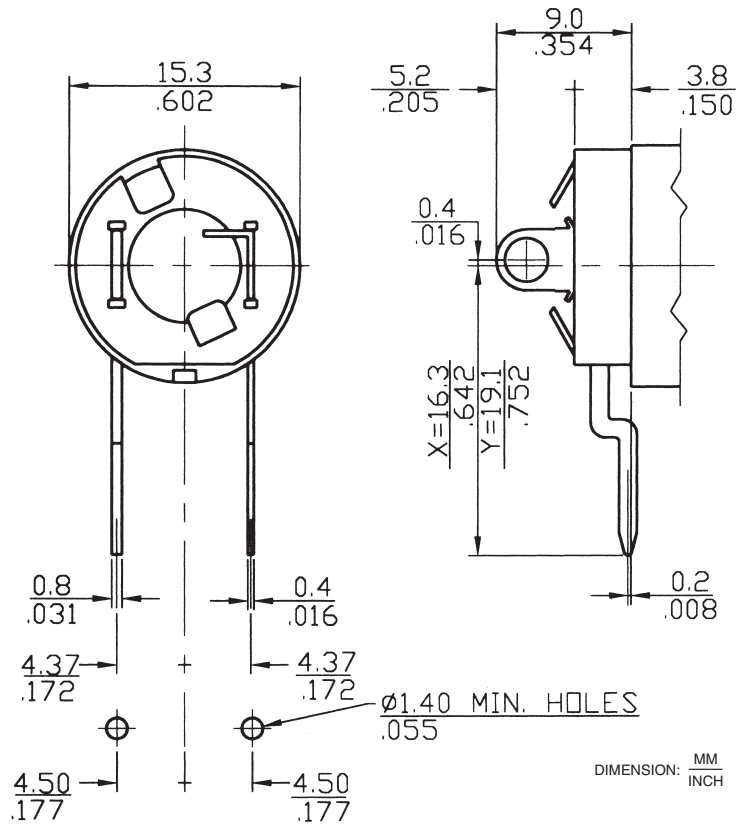

| SERIES | TYPE | ELECTRICAL RATING |
|--------|------------------------------|-------------------|
| DEMI | Push-Pull | 3A @ 20 VDC |
| DEMI | Momentary contact Push on | 3A @ 20 VDC |

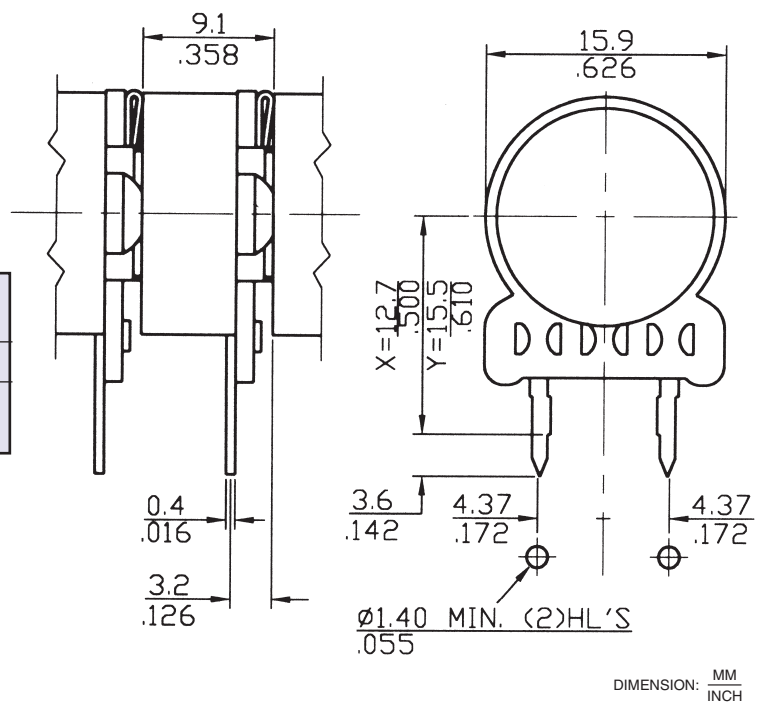

T270 Solder Lug Terminals, Metal Shaft, Bushing Mount

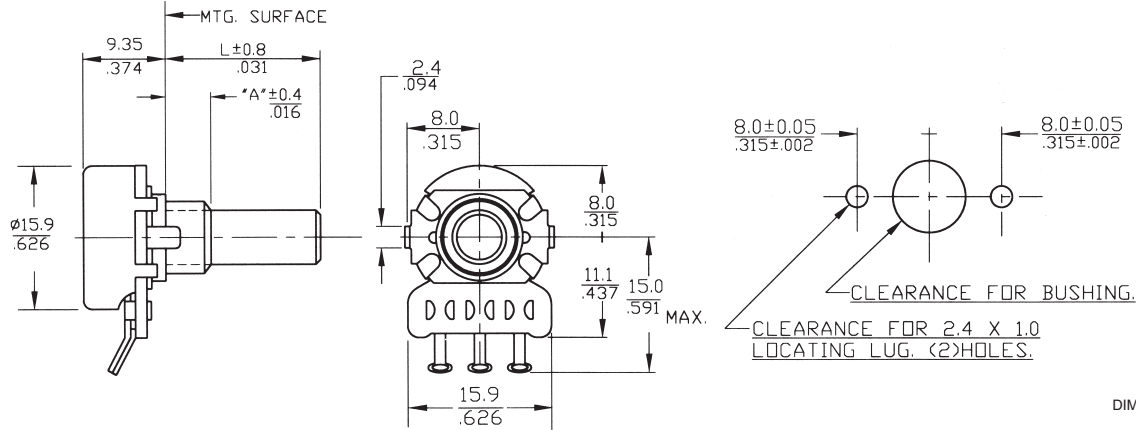

BX PM270 PC Type Base "X" Terminals, 2-Ear Mount Bend Tab, Molded Shaft

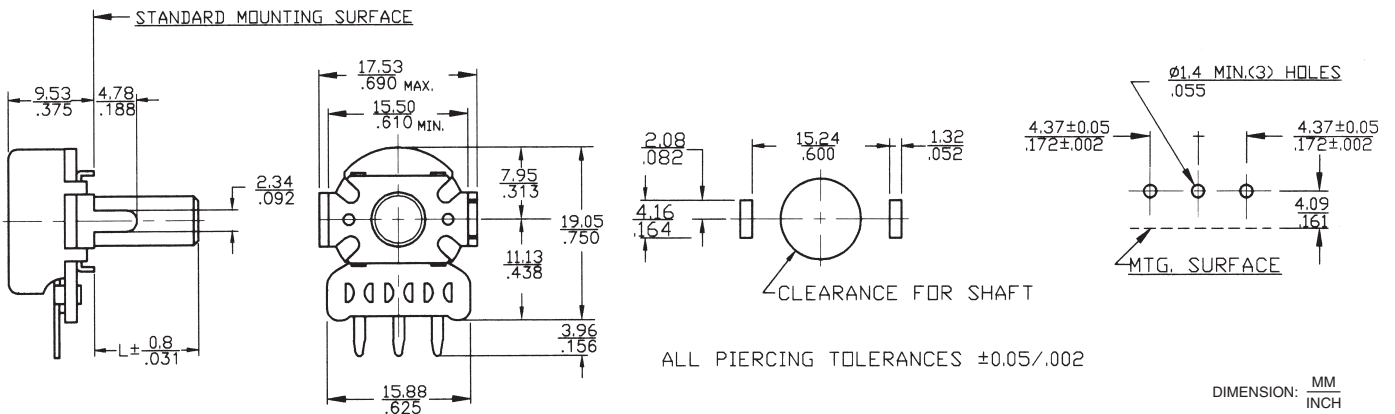

UPE 270RE PC Type "U" Terminals, Twist Tab Mount, Metal Shaft, Rear Extension

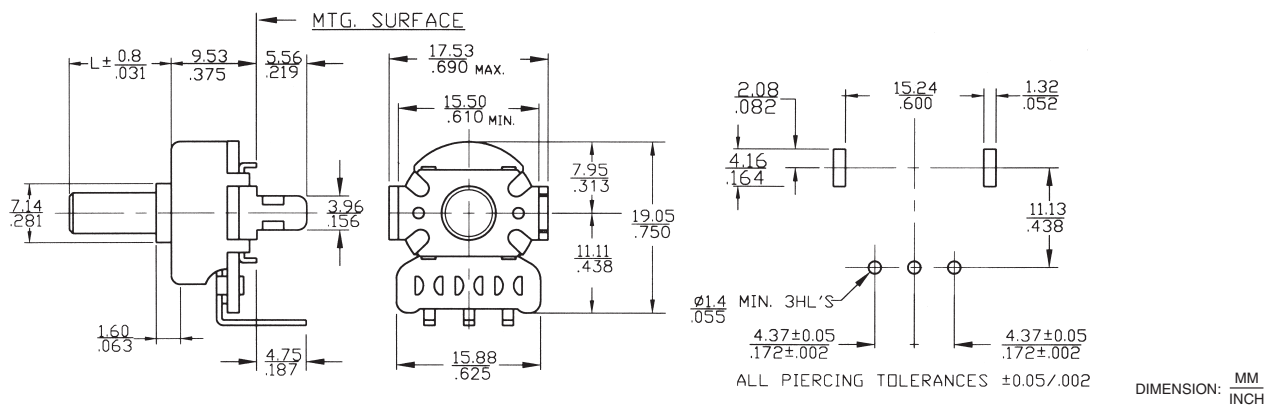

XB275RE PC Type "X" Terminals, Metal Shaft, Rear Extension

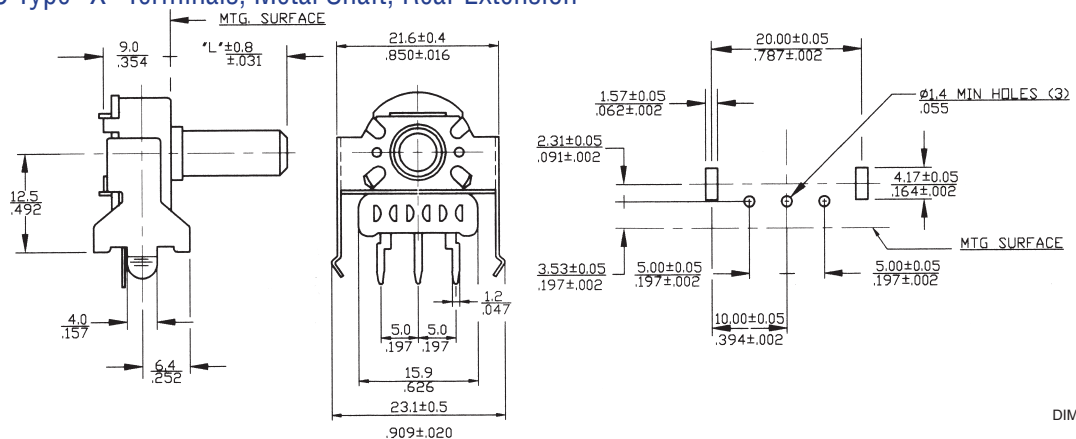

VPE 270 PC Type "V" Terminals, Twist Tab Mount, Metal Shaft

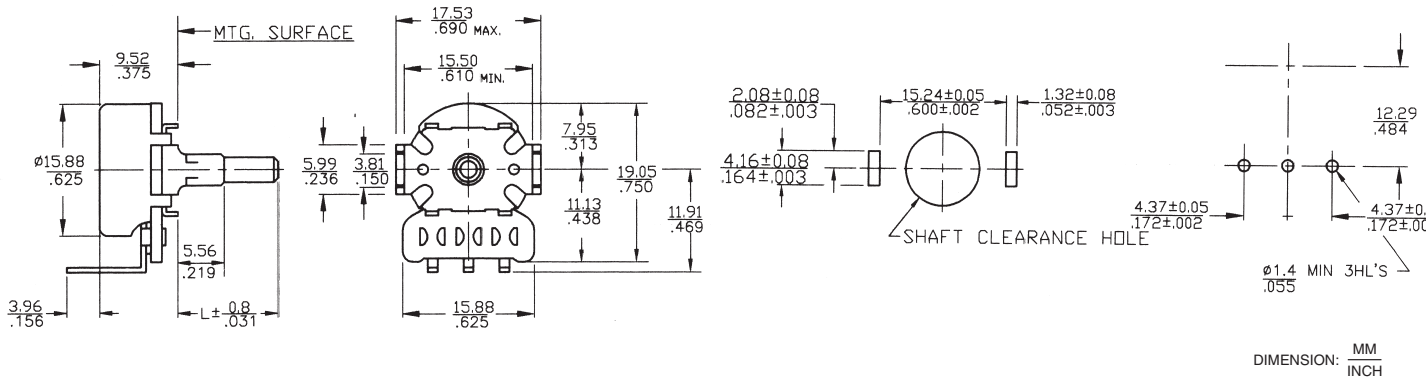

X057-BX270 PC Type Terminal SPST Switch, PC Style Base "X" Terminals, Metal Shaft, Bushing Mount

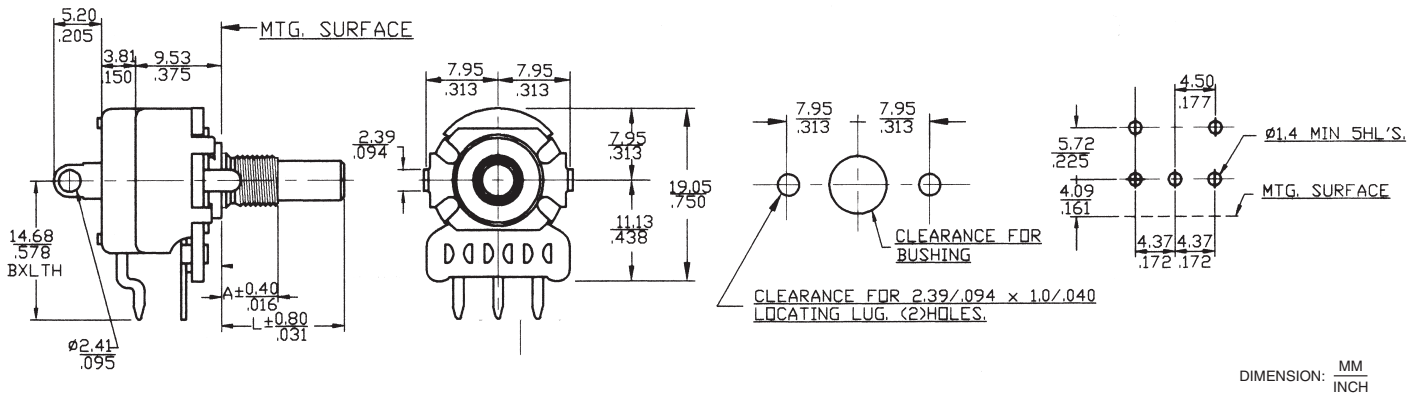

T2-270 Solder Lug Terminals, Straight Tandem, Metal Shaft, Bushing Mount

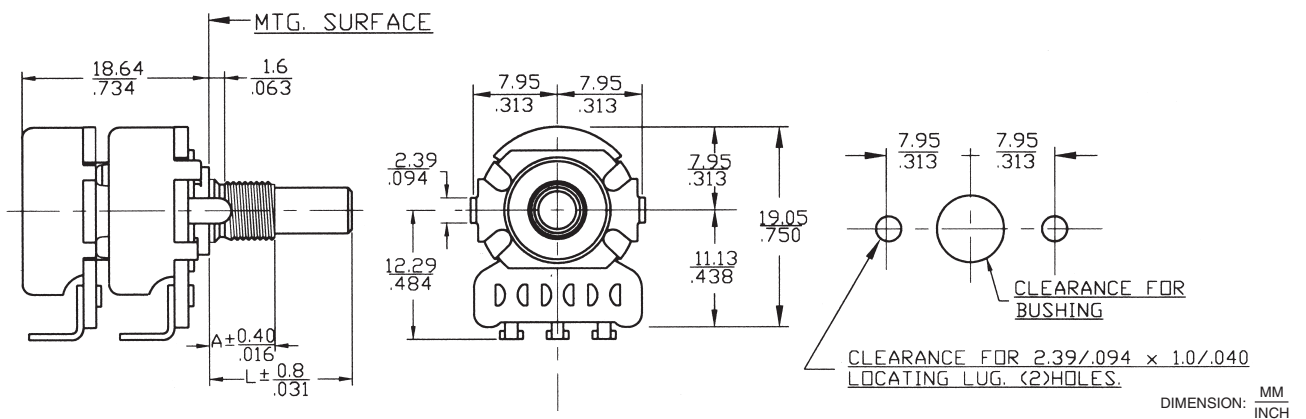

XP275 PC Type "X" Terminal, Metal Shaft, Twist Tab Mounting

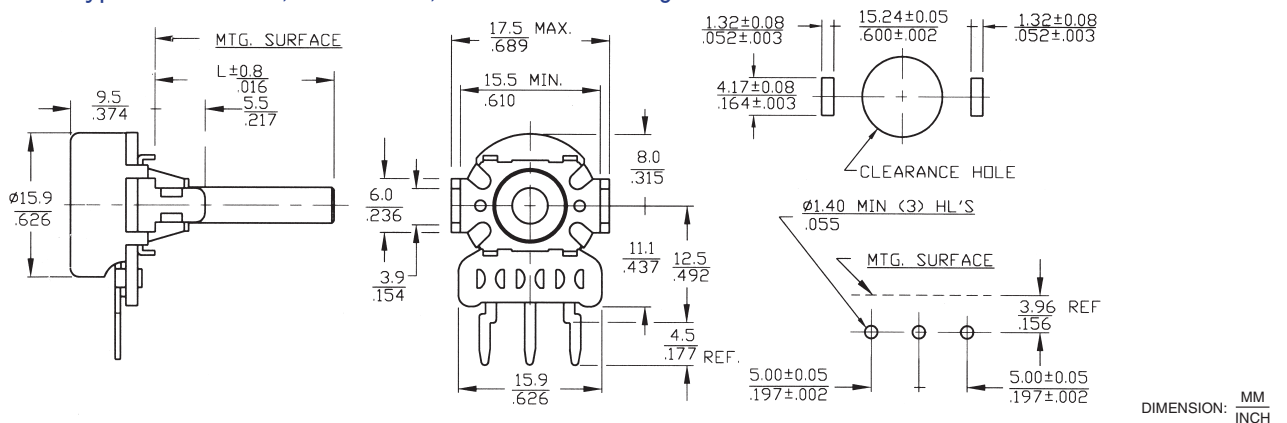

7057-C2-270 Solder Lug Terminal SPST Switch, Solder Lug Terminals, Concentric Metal Shafts, Bushing Mount

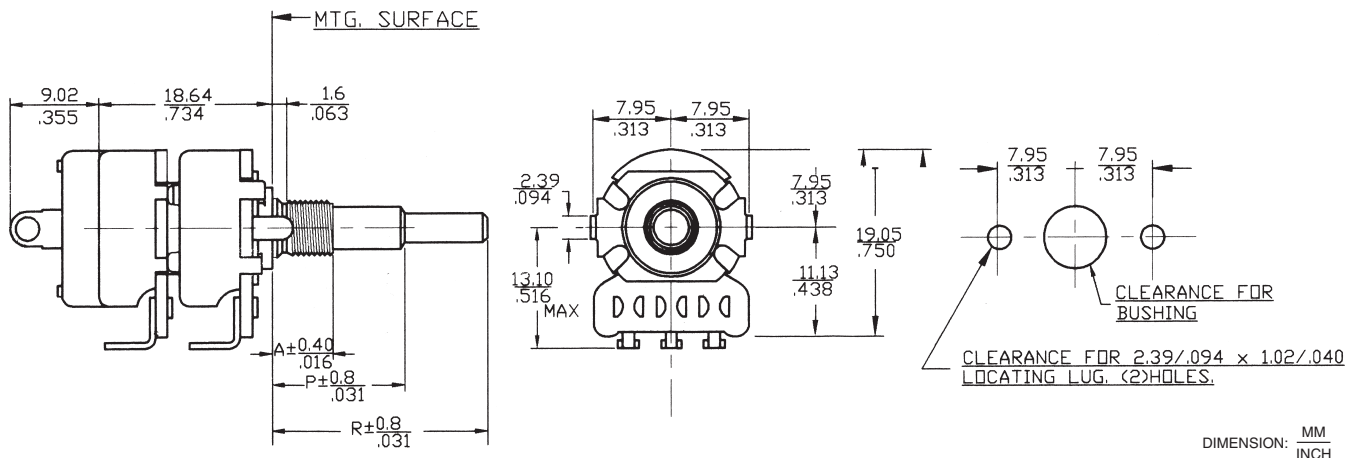

Ordering Information

270/275 T 2 20 R 103 B 1 A 1

TERMINAL STYLE

T - SOLDER LUG
X - PC*
U - FORMED TO FRONT
V - FORMED TO REAR
W - FORMED TO REAR

SHAFT LENGTH

From Mounting Surface 1/32" (0.8mm) Increments
Examples:
Metal Shafts
20 - .625" (15.9MM)
24 - .750" (19.1MM)
28 - .875" (22.2MM)
32 - 1.000" (25.4MM)
Moulded Shafts
Limited Lengths Available, See Shaft Trim selection
16 - Shaft U, .500" (12.7MM)
28 - Shaft V, .875" (22.2MM)
32 - Shaft W, 1.0" (25MM)

RESISTANCE CODE EXAMPLES

| CODE | RESISTANCE |
|------|------------|
| 501 | 500 OHMS |
| 102 | 1K |
| 252 | 2.5K |
| 502 | 5K |
| 103 | 10K |
| 253 | 25K |
| 503 | 50K |
| 104 | 100K |

TAPER

1 - LINEAR
2 - 10% AUD
3 - 10% CCW AUD

SWITCH TYPE

A - NONE
B - SPST ROTARY

SHAFT TRIM

A - .125" DIAM. ROUND BRASS
B - .125" DIAM. FLAT BRASS
C - .125" DIAM. SD SLOT BRASS
R - .156" DIAM. ROUND BRASS
F - .156" DIAM. FLAT BRASS
S - .156" DIAM. SD SLOT BRASS
G - .187" DIAM. ROUND BRASS
H - .187" DIAM. FLAT BRASS
J - .187" DIAM. SD SLOT BRASS
X - .236" DIAM. ROUND BRASS
L - .236" DIAM. FLAT BRASS
M - .236" DIAM. SD SLOT BRASS
N - .236" DIAM. SK BRASS
P - .250" DIAM. ROUND BRASS
D - .250" DIAM. FLAT BRASS
E - .250" DIAM. SD SLOT BRASS
T - .250" DIAM. SK BRASS
U - .187" DIAM. .500" FMS SK MOLDED
V - .187" DIAM. .875" FMS FLAT MOLDED
W - .236" DIAM. .984" FMS FLATTED (.472" X .177") MOLDED
K - .236" DIAM. .500" FMS SK MOLDED (SWITCH ONLY)

RESIST TOL

A - ±10%
B - ±20%
C - ±30%

SPECIALS

1 - NONE
2 - 50% DETENT
4 - LOCATING LUG FOR RIGHT SIDE
5 - NO LOCATING LUG

MOUNTING STYLE

BUSHING LENGTH: 1/8" (3.2MM) INCREMENTS

EXAMPLES:
2 - .250" (6.35MM)
3 - .375" (9.5MM)
8 - 1.000" (25.4MM)
1 - TWIST TAB MOUNT
BUSHING MOUNT SUPPLIED WITH LOCATING LUG LEFT SIDE TERMINALS DOWN

NOTES: 275 series available in "X" and "U" style PC Terminals only.
.125" dia. & .156" dia. shaft thickness is .109".
.187" dia. shaft flat thickness is .156".
.236" dia. shaft flat thickness is .177".
.250" dia. shaft flat thickness is .156".

*BX construction and terminal length supplied unless otherwise specified

Order From:

CTS CORPORATION, RESISTOR/ELECTROCOMPONENTS / 1601 Mishawaka Street / Elkhart, Indiana 46514
North America Toll Free (888) 287-4690 / (219) 296-6700 / FAX: (219) 293-1240 <http://www.ctscorp.com>

CTS COMPONENTS TAIWAN, LTD. / 7, Central 6th Road (Chung Liu Road) / P.O. Box 26-20
Kaohsiung Export Processing Zone / Kaohsiung, Taiwan, Rep. of China
(07) 8216145 / FAX: (07) 8417642.8110040