

THAT 2162 Demo Board
User's Guide

Document 600129 Rev 03

Contents

Packing List 2
Overview 3
Features 3
Theory of Operation 4
Modes and Jumpers 6
External Control Voltage (CV) 7
Specifications..... 7
Appendix A - Schematic 8
Appendix B - Bill of Materials..... 9
Appendix C - PCB Layout 11

Packing List

- (1) THAT2162 DEMO Board PCB Assembly
- (1) THAT2162Q16-U Chip (in a separate antistatic bag or tube)
- (1) Documentation Packet

If you are missing any of the above items please contact us at support@thatcorp.com.

Overview

The THAT2162 DEMO BOARD enables you to take the THAT2162 Dual VCA chip for a test drive. It implements several typical applications that showcase the utility of a dual VCA - stereo audio level control with better than 1dB gain matching, constant power panning (for mono signals) and balance (for stereo signals), and a 2-in/1-out crossfader. You can adjust these parameters using on-board pots or by applying an external DC control voltage (CV) via banana connectors. Inputs and outputs are available on balanced TRS or XLR connectors via high performance THAT1243 and THAT1606 OutSmarts™ balanced line receivers/drivers.

Features

- THAT2162 Dual VCA
- Dual Mono signal path - Chan 1 and Chan 2
- Each channel is input via Neutrik TRS/XLR Combo connectors
- Each channel is output via parallel XLR and TRS connectors
- CV for each VCA can be generated from on-board potentiometer or input from an optional external power supply
- CV for Chan 2 can be independent or slaved to Chan 1
- Pan/Balance circuit generates sin/cos law control voltage for constant power operation
- Optional Crossfade of Chan 1 and Chan 2 inputs to Chan 1 output
- Prototype area (100mil spaced plated holes) allows designer to experiment with custom applications

Theory of Operation

Figure 1 is a block diagram of the THAT2162 DEMO BOARD. Admittedly, Figure 1 is a bit complex, so let's take it one step at a time.

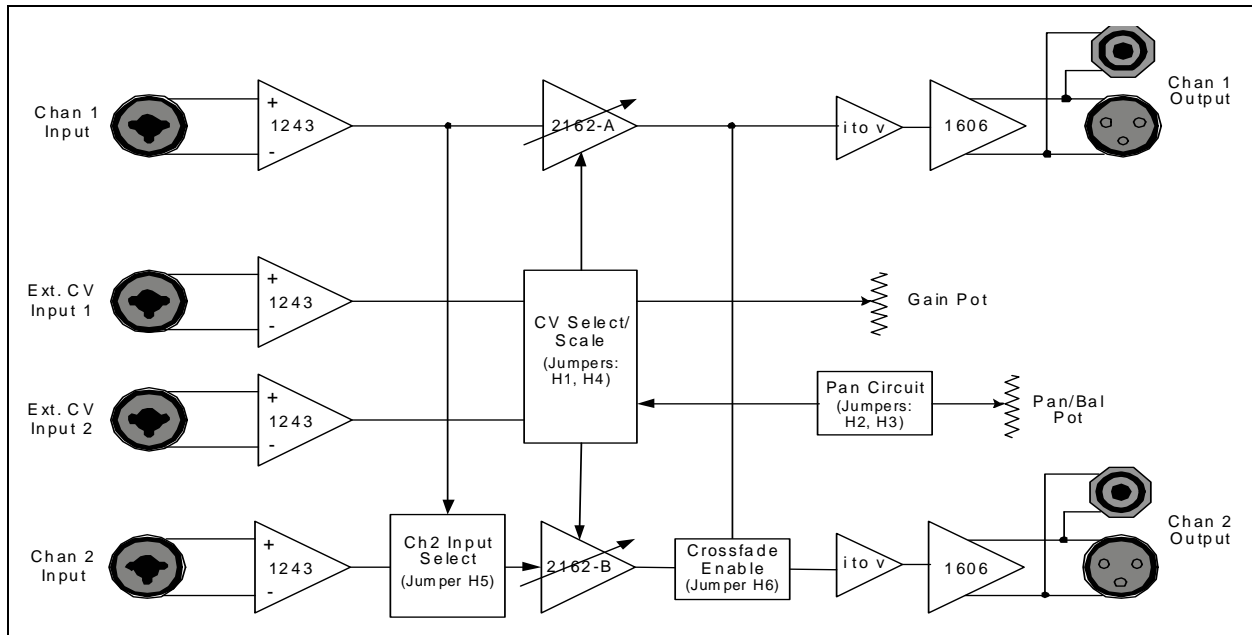

Figure 1 -- Block diagram of THAT2162 DEMO BOARD

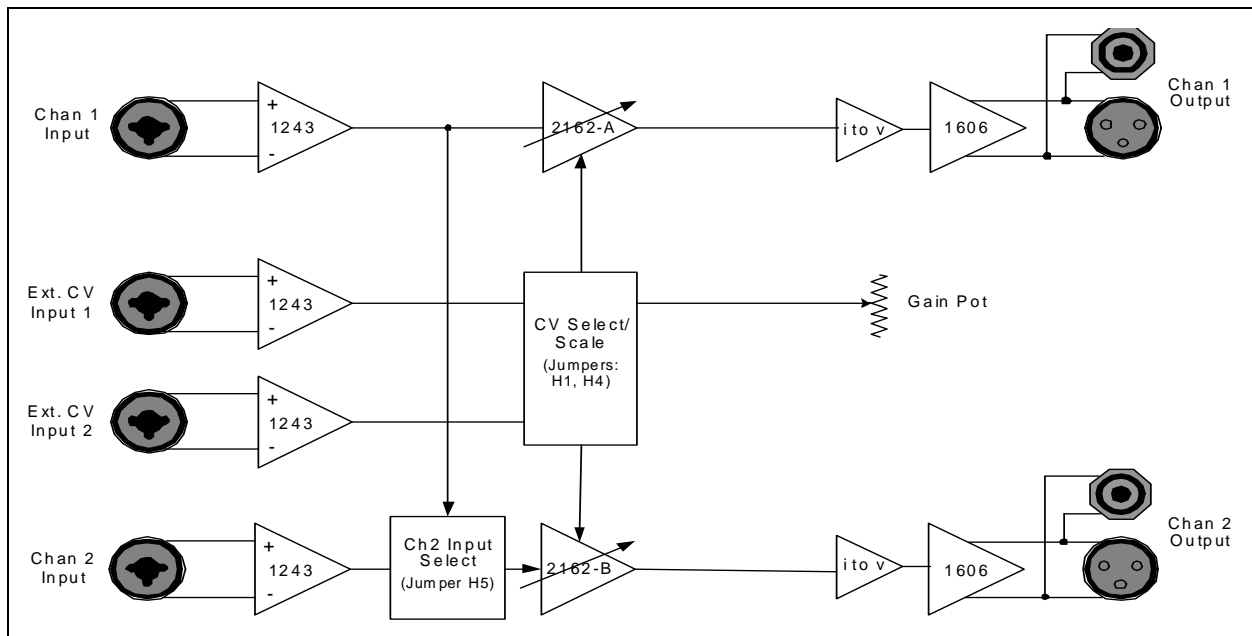

Figure 1a -- Block diagram of THAT2162 DEMO BOARD, Basic Gain Control

Figure 1a shows the basic stereo signal flow of the circuit. The Chan 1 input goes through one half of the THAT2162 VCA, a current-to-voltage buffer, and is output by the THAT1606 OutSmarts™ balanced line driver. Chan 2 can take a similar path to the Chan 2 output, or it can optionally carry the Chan 1 input via jumper

H5 (this option is necessary for Pan and Crossfade modes, explained later). The on-board GAIN potentiometer, or the Chan 1 and Chan 2 External CV inputs, can be used to control the VCAs, selected via jumpers H1 and H4.

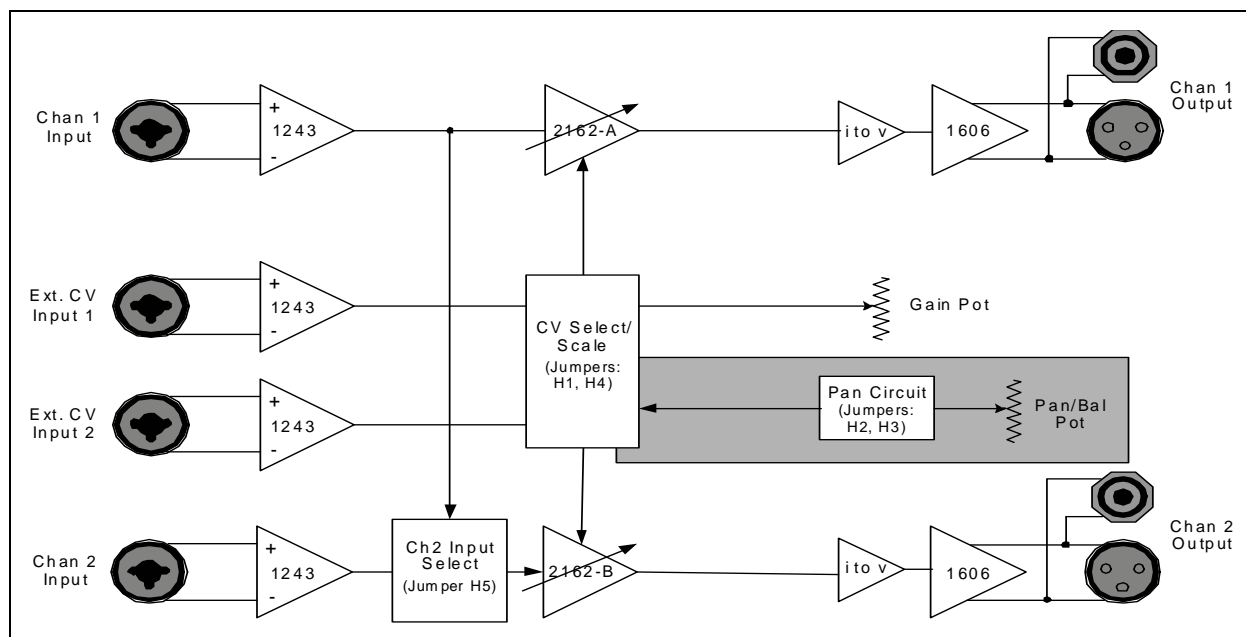

Figure 1b -- Block diagram of THAT2162 DEMO BOARD, Pan and Balance added

In Figure 1b a pan conditioning circuit has been added. Please read THAT Corporation Design Note 120 - VCAs in Pan Potentiometer Application for details on how this circuit works. In a nutshell, this conditioning circuit creates the proper CV to give a "sin/cos" "equal-power" taper. Jumpers H2 and H3 select whether the Pan CV is summed with the Gain CV (thereby enabling the Pan function). Of course, for the Pan function to work, a single input signal must be steered between both outputs. Jumper H5 optionally feeds the Chan 1 input to both halves of the VCA in MONO input mode to enable the Pan function.

Note that Stereo Balance can be enabled by running the circuit in Figure 1b with separate "left" and "right" inputs (corresponding to Chan 2 and Chan 1 respectively). Thus, jumper H5 must be set for STEREO input mode for Balance to work.

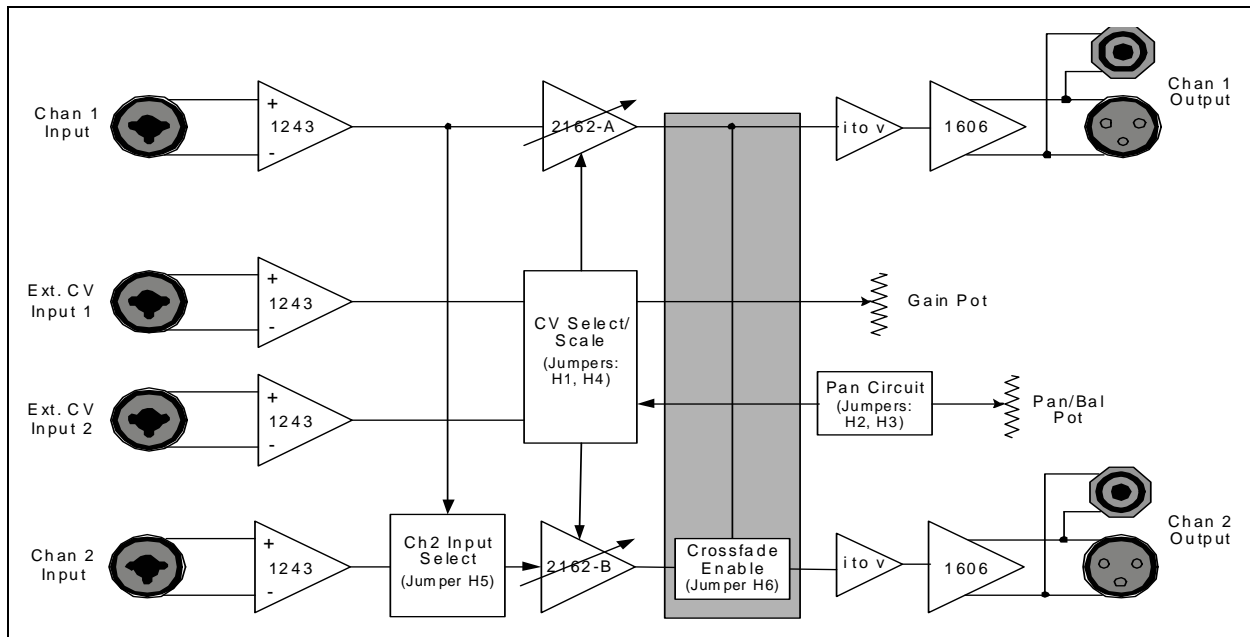

Figure 1c -- Block diagram of THAT2162 DEMO BOARD, Crossfade added

Finally, as shown in Figure 1c, the Crossfade function is added by steering the output current from VCA-B to the current-to-voltage converter of VCA-A. The current outputs of both VCAs sum in this i-to-v converter and are output via the Chan 1 Output. Jumper H6 selects whether the current output of VCA-B is sent to the Chan 1 (i.e. crossfade) or Chan 2 output (other modes).

The astute reader will notice that Figure 1c and Figure 1 are the same. Thus, this completes our tour through the THAT2162 DEMO BOARD signal topology.

Modes and Jumpers

Table 1 shows how to set the various jumpers on the PCB for the various operating modes.

JUMPERS				
MODE	H1 & H4	H2 & H3	H5	H6
Gain				
Force 0dB	"0dB"	DISABLE	-	STEREO
Controlled by on-board pot	"INTERNAL"	-	-	STEREO
External CV (Chan 1 & 2 separate)	"EXTERNAL INDEPENDANT"	-	-	STEREO
External CV (Chan 1 & 2 slaved)	"EXTERNAL COMMON"	-	-	STEREO
Pan	-	ENABLE	PAN (MONO)	STEREO
Stereo Balance	-	ENABLE	BALANCE (STEREO)	STEREO
Crossfade	-	ENABLE	BALANCE (STEREO)	XFADE

Table 1 -- Modes and Jumpers (Note - a dash means "don't care")

External Control Voltage (CV)

The Chan 1 and Chan 2 External CV Inputs are provided on banana connectors compatible with most DC bench supplies. Each CV is input via THAT1243 balanced line receivers and scaled as follows:

CV Input Voltage	Gain
+2 VDC	+20 dB
0 VDC	0 dB
-7 VDC	-70 dB

Since the THAT1243 Balanced Line Receivers on each CV input are fully differential with no ground reference, they can accept DC inputs in either polarity. Thus, if the polarity of the CV input is flipped (such that red = GND and BLACK = CV+) the circuit can be operated with positive-only control voltages (e.g. 0 to -50dB attenuation using a 5V DAC).

Specifications

<u>Typical Power Supply Requirements</u>						
Parameter	Symbol	Conditions	Min	Typ	Max	Units
Positive Supply Voltage	Vcc		+12	+15	+18	V
Negative Supply Voltage	Vee		-12	-15	-18	V
Supply Current (each supply)	Icc, Iee	Vcc = Vee = 15V	—	80	—	mA

<u>Electrical Characteristics</u>						
Parameter	Conditions	Min	Typ	Max	Units	
Gain Range	Internal Control	-70	—	+40	dB	
	External Control	-70	—	+20	dB	
Control Voltage Range	Differential, CV+ - CV-	-13	—	+13	mV/dB	
Control Voltage Constant	External Control	88	100	112	mV/dB	
THD+N	22Hz - 22kHz, unweighted	—	0.2	—	%	
Dynamic Range	re +24 dBu	—	114	—	dB	
Input Overload	V _{CC} = -V _{EE} = 15 V	—	24	—	dBu	
Dimensions			5 x 7 x 1.5		in	

Appendix A

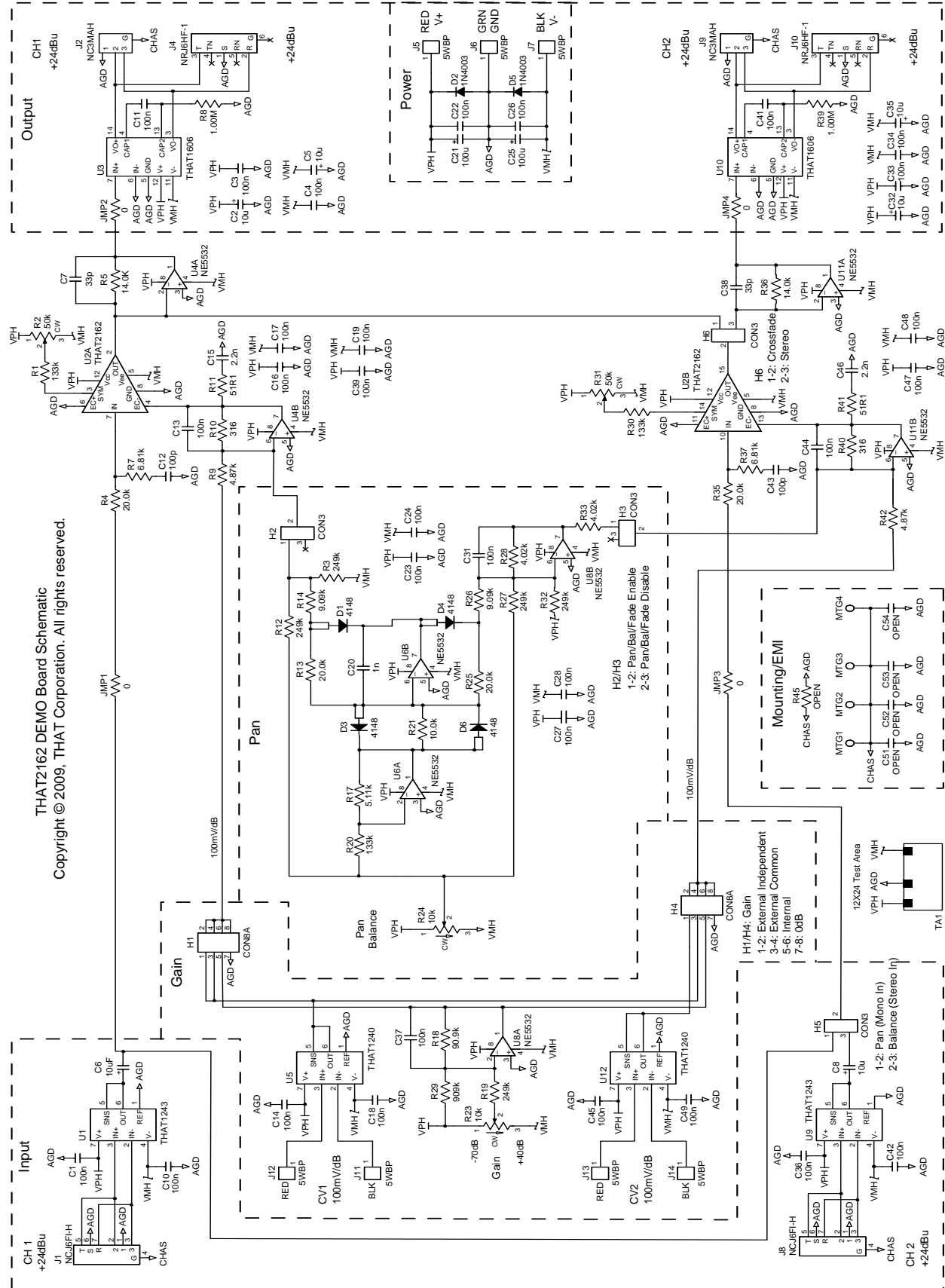

Appendix B

Bill of Materials						
Item	Qty	Ref	Value	Description	MFG	MFG PN
1	2	C7	33pF	CAP CERAMIC 33PF 50V NP0 0805	Yageo	CC0805JRNP09BN330
		C38	33pF			
2	2	C12	100pF	CAP CERAMIC 100PF 50V NP0 0805	Yageo	CC0805JRNP09BN101
		C43	100pF			
3	1	C20	1nF	CAP 1000PF 50V CERAMIC X7R 0805	Yageo	CC0805KRX7R9BB102
4	2	C15	2.2nF	CAP 2200PF 50V CERAMIC X7R 0805	Yageo	CC0805KRX7R9BB222
		C46	2.2nF			
5	30	C1, C3, C4, C10, C11, C13, C14, C16, C17, C18, C19, C22, C23, C24, C26, C27, C28, C31, C33, C34, C36, C37, C39, C41, C42, C44, C45, C47, C48, C49	100nF	CAP .10UF 25V CERAMIC X7R 0805	Yageo	CC0805KRX7R8BB104
6	6	C2, C5, C6, C8, C32, C35	10uF	CAP 10UF 25V ELECT WT SMD	Nichicon	UWT1E100MCL1GB
7	2	C21, C25	100uF	CAP 100UF 25V ELECT WT SMD	Nichicon	UWT1E101MCL1GS
8	4	D1, D3, D4, D6	4148	DIODE SWITCH 75V 350MW SOT23	Diodes Inc	MMBD4148-7-F
9	2	D2, D5	1N4003	RECTIFIER GPP 200V 1A DO-41	Diodes Inc	1N4003-T
10	0.33	H2, H3, H5, H6	CON3	CONN HEADER 36POS .100 VERT GOLD	Molex/Wald om	22-28-4363
11	0.20	H1, H4	CON8A	CONN HDR DUAL 80POS .100 SRT AU	Molex/Wald om	75102-0078
12	3	J5, J11, J13	5WBP	POST BINDING BANANA INSULATED RED	Pomona	3760-2
13	3	J6, J12, J14	5WBP	POST BINDING BANANA INSULATED BLK	Pomona	3760-0
14	1	J7	5WBP	POST BINDING BANANA INSULATED GRN	Pomona	3760-5
15	2	J2, J9	NC3MAH	XLR Panel Mount Connectors 3C MALE PCB	Neutrik	NC3MAH
16	2	J1, J8	NCJ6FI-H	Phone Jacks XRL COMBO STEREO	Neutrik	NCJ6FI-H
17	2	J4, J10	NRJ6HF-1	Phone Jacks 3C STEREO 3-SPST NC	Neutrik	NRJ6HF-1
18	4	JMP1, JMP2, JMP3, JMP4	0	JUMPER ZERO OHM 1/4W	Yageo	ZOR-25-B-52
19	2	R23, R24	10K	POT 10K OHM 9MM SQ PLASTIC	Bourns	3386F-1-103TLF
20	2	R2, R31	50k	TRIMMER POT 50K OHM TOP ADJ	BC Compo- nents	CT-94W-503
21	2	R11, R41	51.1	RES 51.1 OHM 1/8W 1% 0805 SMD	Yageo	RC0805FR-0751R1L
22	2	R10, R40	316	RES 316 OHM 1/8W 1% 0805 SMD	Yageo	RC0805FR-07316RL
23	2	R28, R33	4.02k	RES 4.02K OHM 1/8W 1% 0805 SMD	Yageo	RC0805FR-074K02L

24	2	R9, R42	4.87k	RES 4.87K OHM 1/8W 1% 0805 SMD	Yageo	RC0805FR-074K87L
25	1	R17	5.11k	RES 5.11K OHM 1/8W 1% 0805 SMD	Yageo	RC0805FR-075K11L
26	2	R7, R37	6.81k	RES 6.81K OHM 1/8W 1% 0805 SMD	Yageo	RC0805FR-076K81L
27	2	R14, R26	9.09k	RES 9.09K OHM 1/8W 1% 0805 SMD	Yageo	RC0805FR-079K09L
28	1	R21	10.0k	RES 10.0K OHM 1/8W 1% 0805 SMD	Yageo	RC0805FR-0710K0L
29	2	R5, R36	14.0K	RES 14.0K OHM 1/8W 1% 0805 SMD	Yageo	RC0805FR-0714K0L
30	4	R4, R13, R25, R35	20.0k	RES 20.0K OHM 1/8W 1% 0805 SMD	Yageo	RC0805FR-0720K0L
31	1	R18	90.9k	RES 90.9K OHM 1/8W 1% 0805 SMD	Yageo	RC0805FR-0790K9L
32	3	R1, R20, R30	133k	RES 133K OHM 1/8W 1% 0805 SMD	Yageo	RC0805FR-07133KL
33	5	R3, R12, R19, R27, R32	249k	RES 249K OHM 1/8W 1% 0805 SMD	Yageo	RC0805FR-07249KL
34	1	R29	909k	RES 909K OHM 1/8W 1% 0805 SMD	Yageo	RC0805FR-07909KL
35	2	R8, R39	1.00M	RES 1.00M OHM 1/8W 1% 0805 SMD	Yageo	RC0805FR-071ML
36	5	U4, U6, U8, U11	NE5532	IC OP AMP DUAL LOW-NOISE SOIC	TI	NE5532DR
37	2	U5, U12	THAT1240	Balanced Line Receiver, 0dB	THAT Corp	1240S08-U
38	2	U1, U9	THAT1243	Balanced Line Receiver, -3dB	THAT Corp	1243S08-U
39	2	U3, U10	THAT1606	Balanced Line Drivers	THAT Corp	1606Q16-U
40	1	U2	THAT2162	Dual Voltage Controlled Amplifiers	THAT Corp	2162Q16-U
41	1	U2	THAT2162	QSOP-16 Socket	ENPLAS TESCO	OTS-16(28)-0.635-02

Appendix C

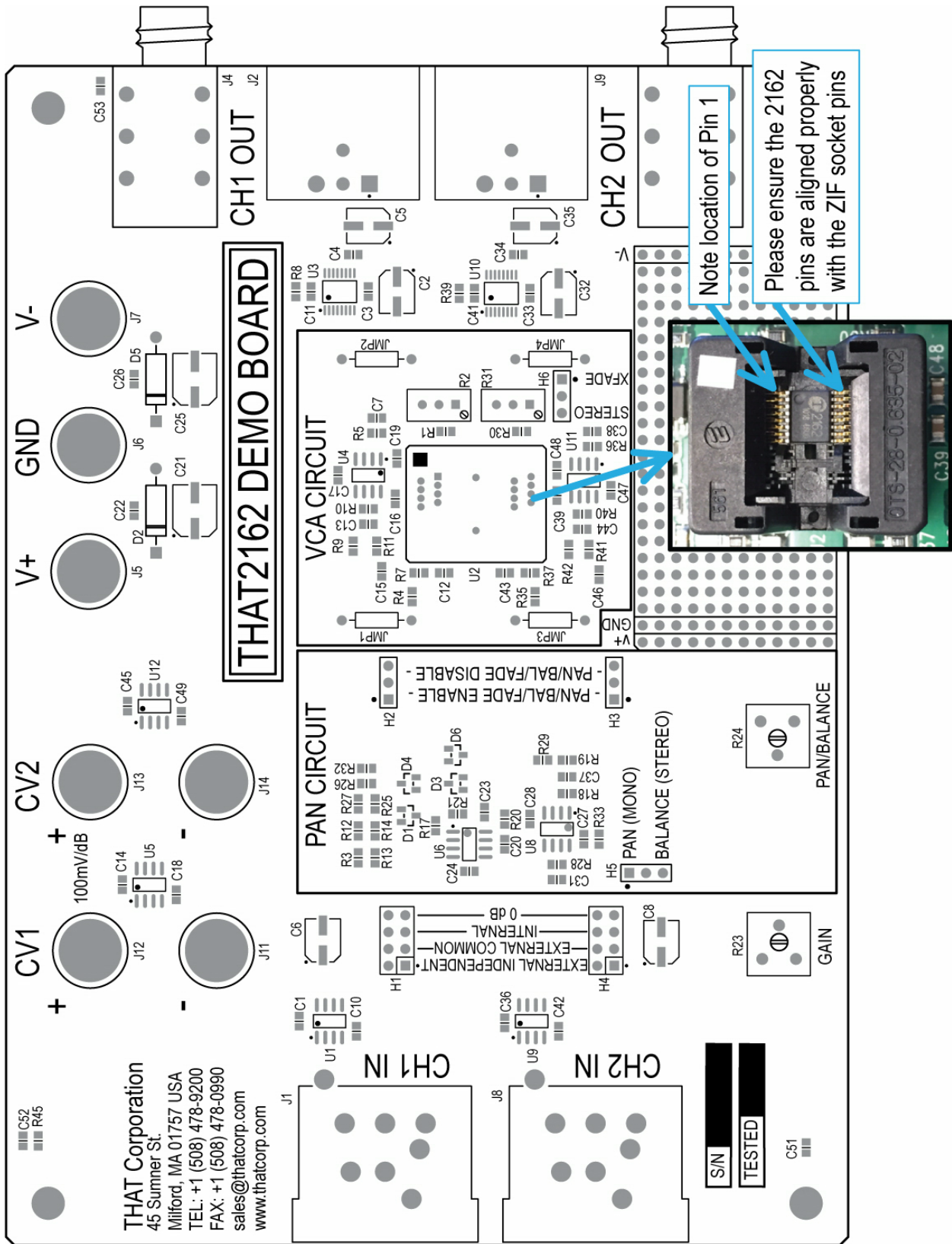

Revision History

Revision	ECO	Date	Changes	Page
00	—	June 2009	Released	—
01	—	July 2010	Made the following schematic corrections: - Chg'd R27 and R32 to 249 kOhms. - Chg'd connection to R24 from "AGD" to "VMH" - Reversed the pin numbers for jumper H2/H3 Pan/Bal/Fade Enable/Disable	8
02	2481	January 2011	Made the following schematic correction: Changed connection to R32 from "VMH" to "VPH"	8
03	2914	March 2015	Changed the assembly dwg to clarify the location and orientation of pin 1 of the 2162 IC.	11

Mouser Electronics

Authorized Distributor

Click to View Pricing, Inventory, Delivery & Lifecycle Information:

[THAT Corporation:](#)

[2162-DEMO](#)