

**PROPRIETARY DATA:**  
 This document and information contained  
 may not be reproduced, used or disclosed  
 without prior written permission of WESTCOR  
 a division of VICOR Corporation.

| REVISIONS |     |                    |          |          |
|-----------|-----|--------------------|----------|----------|
| ECO       | REV | DESCRIPTION        | DATE     | APPROVED |
| 127B      | A   | PRODUCTION RELEASE | 08/13/03 | RME      |

- J10 INTERFACE**
- J10-1 E/D-1
  - J10-2 E/D-2
  - J10-3 E/D-3
  - J10-4 E/D-4
  - J10-5 E/D-5
  - J10-6 E/D-6
  - J10-7 E/D-7
  - J10-8 E/D-8
  - J10-9 Vcc +5V, 0.3A
  - J10-10 SIGNAL GROUND
  - J10-11 AC POWER OK
  - J10-12 GEN SHUTDOWN
- MATING HDWR:**  
 HOUSING-MOLEX P/N: 38-01-2120,  
 TERMINALS-MOLEX P/N: 39-00-0039  
 CRIMP TOOL-MOLEX P/N: 11-01-0122

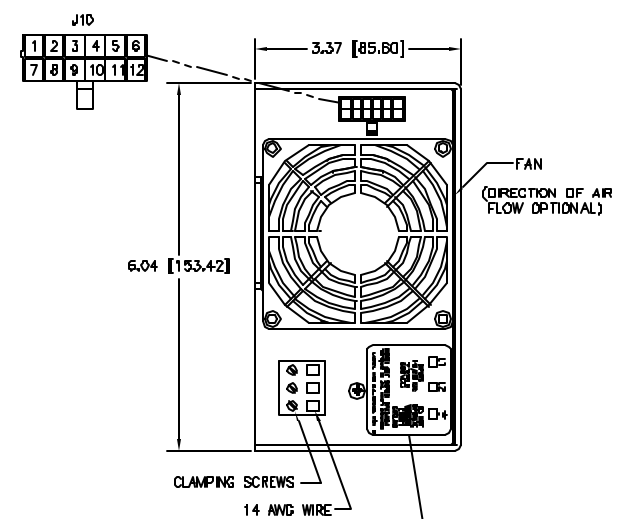

**INPUT CONNECTIONS**

|                   |    |              |                                     |
|-------------------|----|--------------|-------------------------------------|
| J0-1 EARTH GROUND | L1 | INPUTS       | DO NOT OPERATE WITHOUT EARTH GROUND |
| J0-2 L2-NEUTRAL   | L2 | 115/230 VAC  |                                     |
| J0-3 L1           |    | 47 TO 500 Hz |                                     |
|                   |    | 300VDC       |                                     |

NOTE: SET SCREW MAXIMUM TORQUE = 4.4 NCM POUNDS  
 LABEL NO: 84-00046 REV B

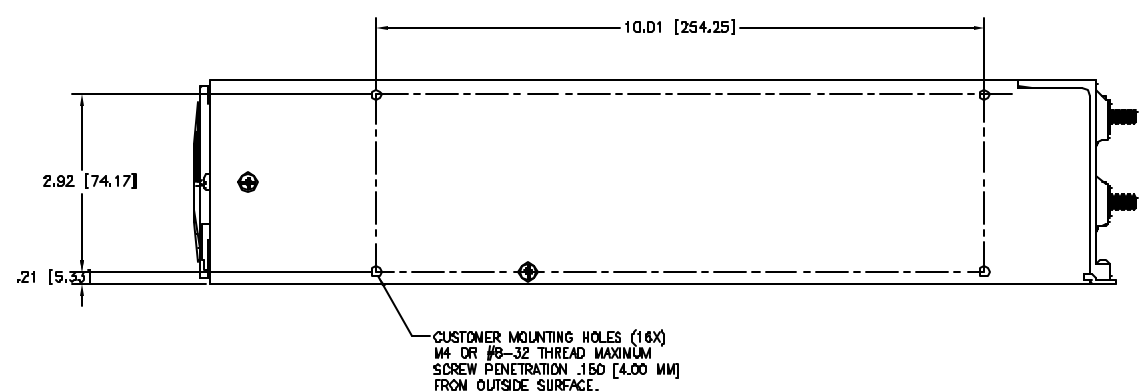
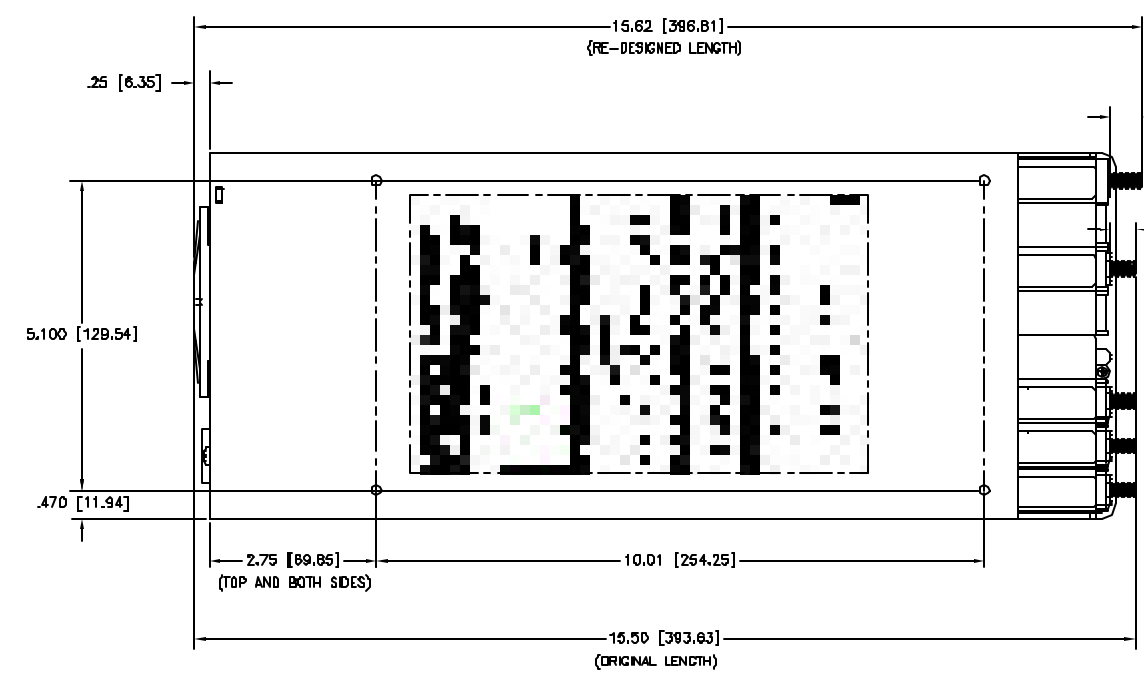
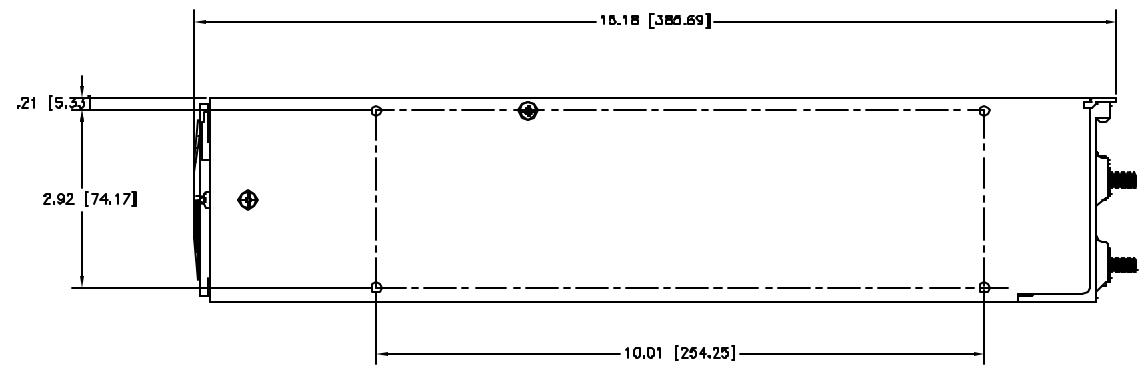

.03 [13.39]  
 RE-DESIGNED STUD AND PANEL (SEE SHIT 2)

.41 [10.35]  
 ORIGINAL STUD AND PANEL (SEE SHIT 2)

1/4 - 20 SERRATED FLANGED NUT ZINC PLATED STEEL WITH OPTIONAL BUSS BARS

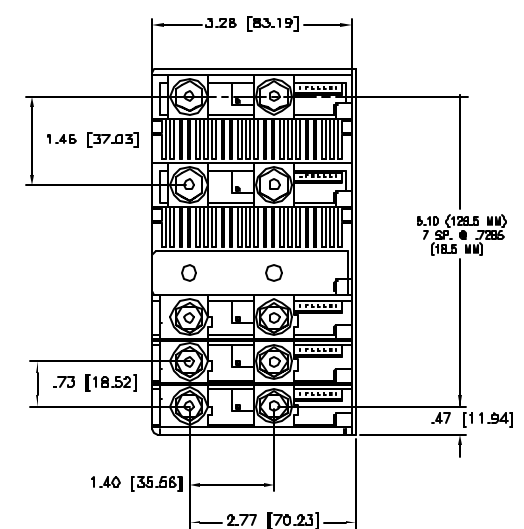

NOTE: A DETAILED DESIGN GUIDE IS AVAILABLE @ [www.vicorpower.com](http://www.vicorpower.com)

| UNLESS OTHERWISE SPECIFIED DIMENSIONS ARE IN INCHES TOLERANCES ARE: |                      | THIRD ANGLE PROJECTION |           | WESTCOR a division of VICOR Corp. |                                  |
|---|----------------------|------------------------|-----------|-----------------------------------|----------------------------------|
| FRACTIONS ± 1/32  | DECIMALS .01         | ANGLES ± 1/2°          | APPROVALS | DATE                              |                                  |
| MATERIAL SEE BOM  | FINISH ---           | APPROVED LARRY KING    | 10/13/99  |                                   |                                  |
| SEE MIS   | USED ON              | CHECKED HUY IDAN       | 10/13/99  |                                   |                                  |
| NEXT ASSY   | DO NOT SCALE DRAWING | APPROVED P.B. DRABING  | 10/13/99  | SIZE D                            | CAGE CODE ---                    |
|   |                      | DESIGNED ---           |           | DWG NO. DB-130149                 | REV A                            |
|   |                      |                        |           | SCALE NTS                         | FILENAME: 08-130149 SHEET 1 OF 2 |

OUTLINE DRAWING PFC MEGAPAC CLEAR (EXT) LENGTH CHASSIS

DWG NO. 08-130149  
 SHEET 1 OF 2

| REVISIONS |     |             |      |          |
|-----------|-----|-------------|------|----------|
| ECO       | REV | DESCRIPTION | DATE | APPROVED |
| ---       | --  | SEE SHEET 1 | ---  | ---      |

MODUPAC/JR.PAC/RAMPAC

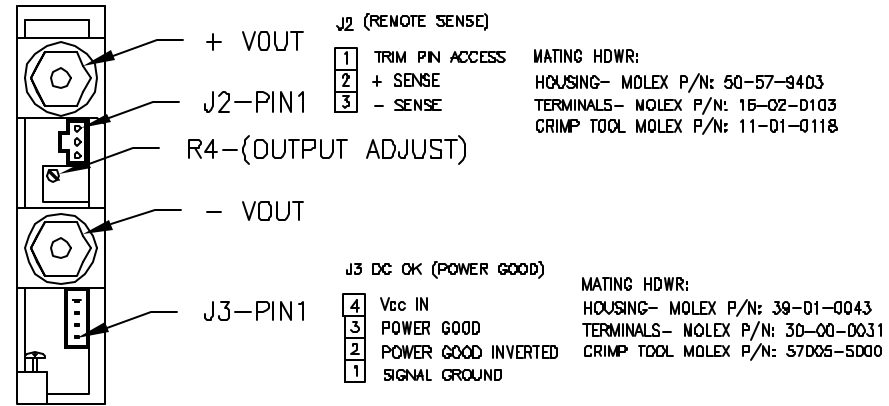

DUALPAC

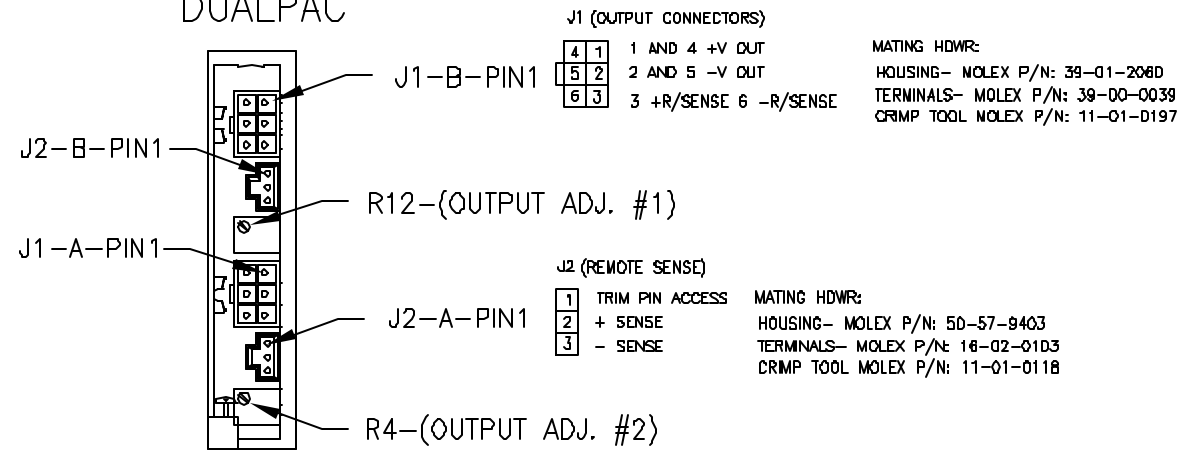

AIR BLOCK

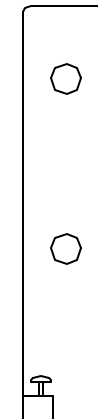

UNIPAC

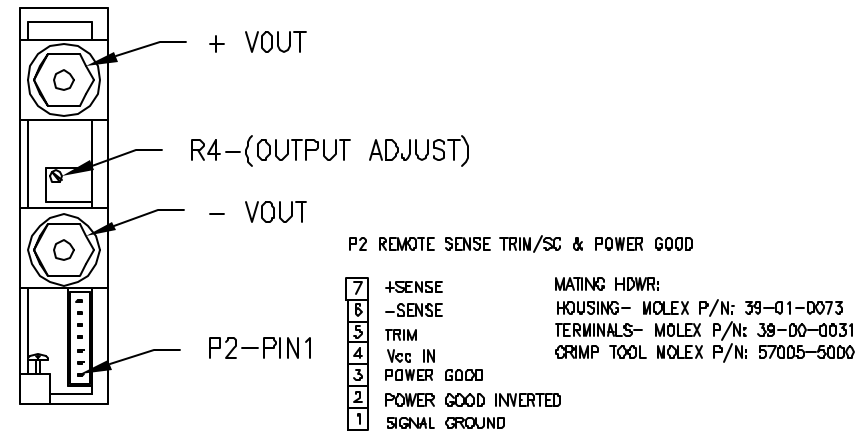

BATPAC

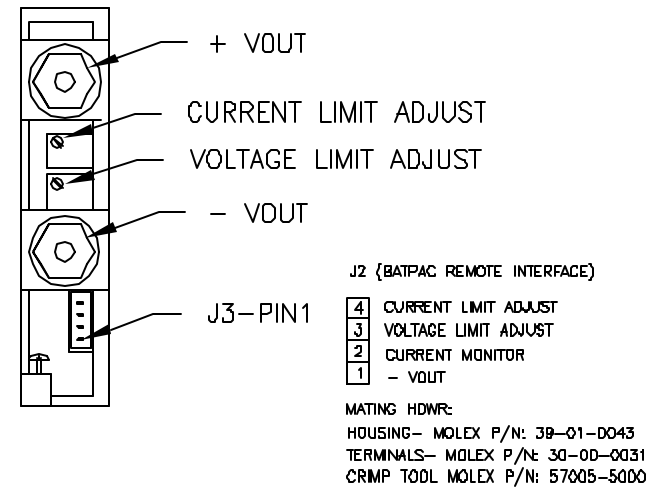

FINPAC

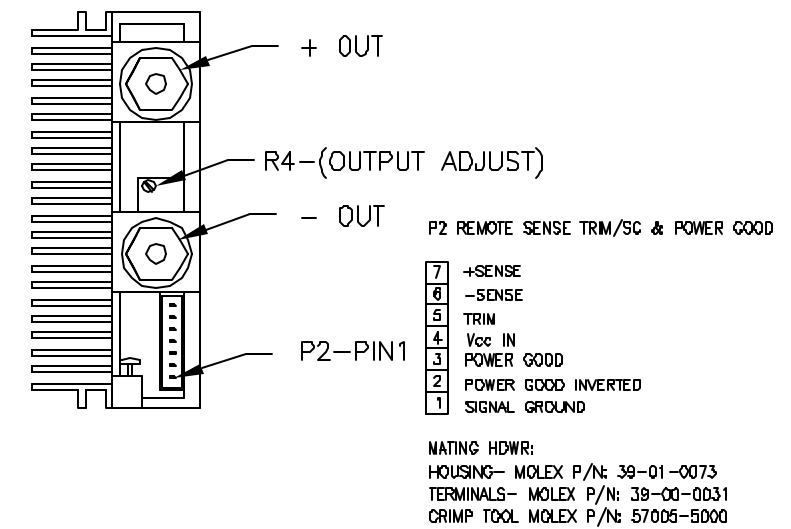

OUTPUT PANEL AND STUDS

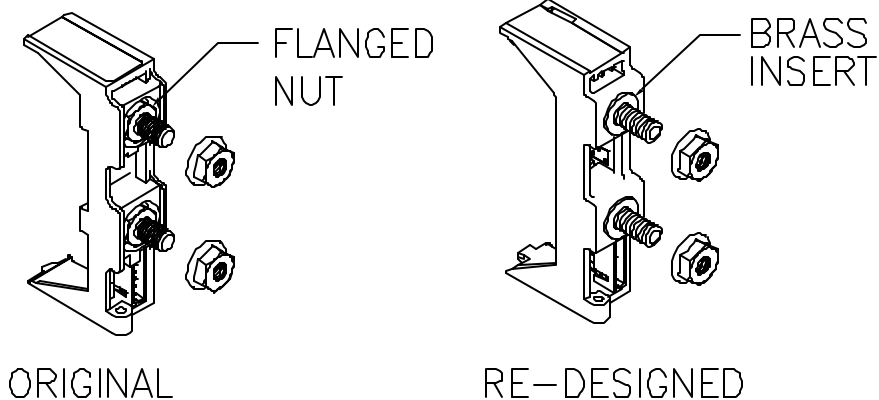

NOTE: EITHER THE ORIGINAL OR RE-DESIGNED OUTPUT STUD AND PANEL COMBINATION MAY BE PRESENT. THE NEW OUTPUT PANEL HAS A BRASS INSERT AND THE STUD IS 1/8 INCH LONGER. (SEE SHEET ONE FOR DIMENSIONAL DATA).

|                                   |  |           |                  |                      |           |
|-----------------------------------|--|-----------|------------------|----------------------|-----------|
| WESTCOR a division of VICOR Corp. | OUTLINE DWG PFC MEGAPAC (STD) LENGTH CHASSIS   |           |                  |                      |           |
|                                   | PROPRIETARY DATA:<br>This document and information contained may not be reproduced, used or disclosed without prior written permission of WESTCOR a division of VICOR Corporation. | SIZE<br>D | CAGE CODE<br>--- | DWG NO.<br>08-130139 | REV<br>A1 |
|                                   | FILENAME: 08-130139  |           | SHEET 2 OF 2     |                      |           |