

VICOR CONFIDENTIAL

THIS DOCUMENT AND THE DATA DISCLOSED HEREIN OR HEREWITH IS NOT TO BE REPRODUCED, USED, OR DISCLOSED IN WHOLE OR IN PART TO ANYONE WITHOUT PERMISSION OF VICOR CORP.

REV.	DESCRIPTION	DATE	APPROVED
#1	DRAWN FOR DEVELOPMENT	CFH	
#2	REVISED PER MKUP	CFH	

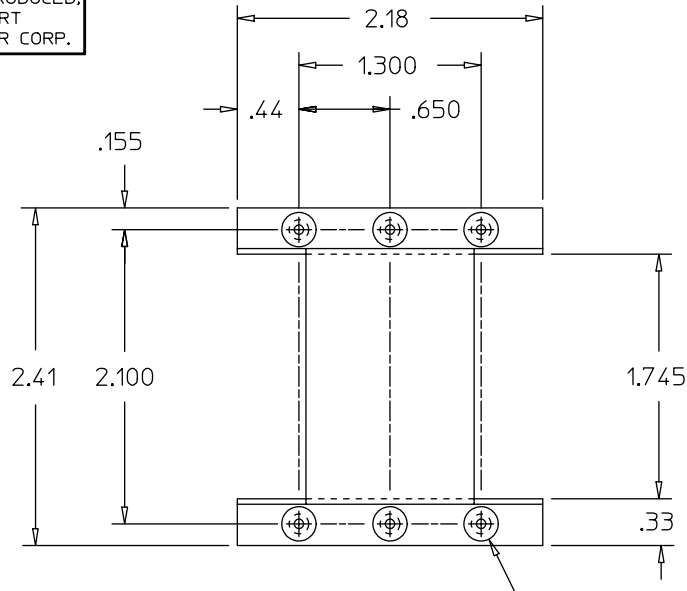

PEM #CLS-440-1
6 PLC'S.

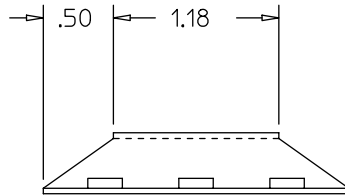
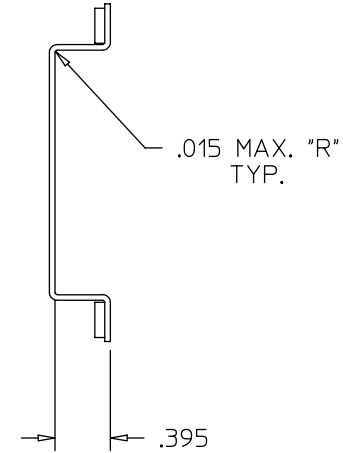

NOTES:

1. MATERIAL: 5052-H34 AL., .040 THICK.
2. REMOVE ALL BURRS & SHARP EDGES.
3. FINISH: CLEAR CHROMATE.

DRAWN BY <i>C HUTCHINS</i>		DATE <i>11/92</i>			
UNLESS OTHERWISE SPECIFIED DIMENSIONS ARE IN INCHES- TOLERANCES ARE: FRACTIONS DECIMALS ANGLES *1/64 .XX= .01 ±1° .XXX= .005					
THIRD ANGLE PROJECTION		SIZE B	FSCM NO. 67131	DWG NO. 07683	REV #2
DO NOT SCALE DRAWING		SCALE FULL		SHEET 1 OF 1	