

Features

- Superscalar IEEE Floating-Point-Processor
- Off-Chip Harvard Architecture Maximizes Signal Processing Performance
- 50 ns, 20 MIPS Instruction Rate, Single Cycle Execution
- 60 MFLOPS Peak, 40 MFLOPS Sustained Performance
- 1024-Point Complex FFT Benchmark: 0.975 ms
- Divide (y/x): 300 ns
- Inverse Square Root (1/ x): 450 ns
- 32-bit Single-Precision and 40-bit Extended-Precision IEEE Floating-Point Data Formats
- 32-bit Fixed-Point Formats, Integer and Fractional, with 80-bit Accumulators
- IEEE Exception Handling with Interrupt on Exception
- Three Independent Computation Units: Multiplier, ALU, and Barrel Shifter
- Dual Data Address Generators with Indirect, Immediate, Modulo, and Bit Reverse Addressing Modes
- Two Off-Chip Memory Transfers in Parallel with Instruction Fetch and Single-Cycle Multiply and ALU Operations
- Multiply with Add and Subtract for FFT Butterfly Computation
- Efficient Program Sequencing with Zero Overhead Looping: Single-Cycle Loop Setup
- Single-Cycle Register File Context Switch
- 23ns External RAM Access Time for Zero-Wait-State, 40 ns Instruction Execution
- IEEE JTAG Standard 1149.1 Test Access Port and On-chip Emulation Circuitry
- 223 CPGA package for breadboarding
- 256 Multi-layer Quad Flat Pack, Flat Leads, For Flight Models
- Fully compatible with Analog Devices ADSP-21020
- No Single Event Latch-up below a LET Threshold of 80 MeV/mg/cm²
- Tested up to a Total Dose of 100 krad (Si) according to MIL STD 883 Method 1019
- SEU Error Note in GEO Orbit Better than 5E⁻⁷ Error/Device/Day (worst case)
- For 25 MHz Specification, Contact Atmel for Availability
- Quality Grades - ESCC with 9512/002 and QML-Q or V with 5962-99539

Introduction

Atmel is manufacturing a radiation hard version of the Analog Devices ADSP-21020 32/40-bit Floating-Point DSP.

The product is pin and code compatible with ADI product, making system development straight forward and cost effective, using existing development tools and algorithms.

- Notes:
1. Design using patent from INPG-CNRS Denis BESSOT/Raoul VELAZCO
 2. Product licensed from Analog Devices Inc.



**Rad. Hard
32/40-bit IEEE
Floating Point
DSP**

TSC21020F

Rev. 4153I-AERO-04/07



Functional Block Diagram

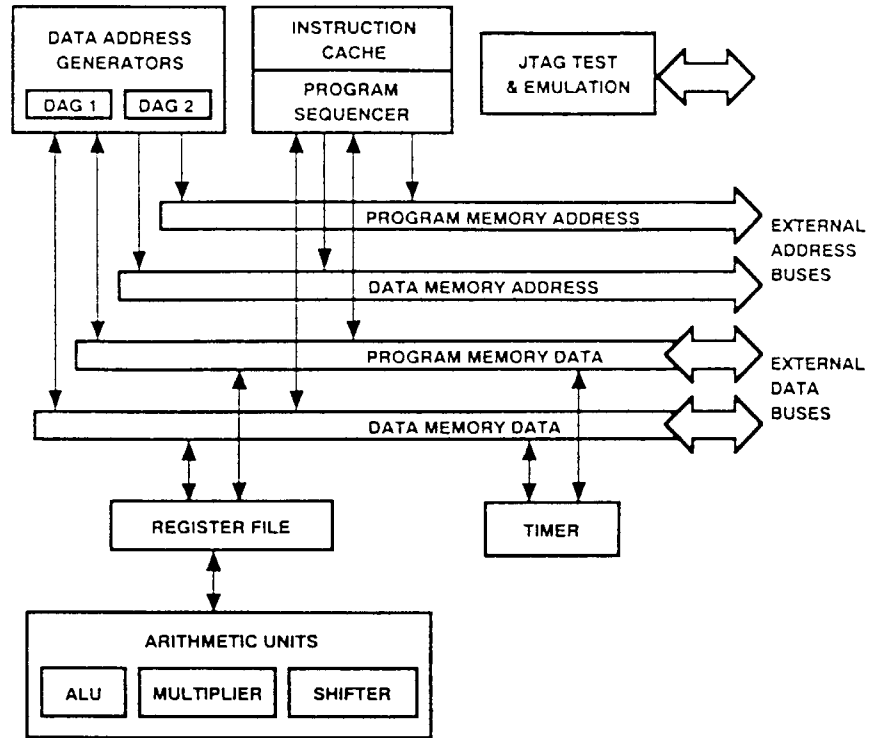

General Description

The TSC21020F is single-chip IEEE floating-point processor optimized for digital signal processing applications ⁽¹⁾. Its architecture is similar to that of Analog Devices' ADSP-2100 family of fixed-point DSP processors.

Fabricated in a high-speed, low-power and radiation hard CMOS process, the TSC21020F has a 50ns instruction cycle time. With a high-performance On-chip instruction cache, the TSC21020F can execute every instruction in a single cycle.

The TSC21020F features:

Independent Parallel Computation Units

The arithmetic/logic unit (ALU), multiplier and shifter perform single-cycle instructions. The units are architecturally arranged in parallel, maximizing computational throughput. A single multifunction instruction executes parallel ALU and multiplier operations. These computation units support IEEE 32-bit single-precision floating-point, extended precision 40-bit floating-point, and 32-bit fixed-point data formats.

Data Register File

A general-purpose data register file is used for transferring data between the computation units and the data buses, and for storing intermediate results. This 10-port (16-register) register file, combined with the TSC21020F's Harvard architecture, allows unconstrained data flow between computation units and off-chip memory.

Single-Cycle Fetch of Instruction and Two Operands

The TSC21020F uses a modified Harvard architecture in which data memory stores data and program memory stores both instructions and data. Because of its separate program and data memory buses and On-chip instruction cache, the processor can simultaneously fetch an operand from data memory, an operand from program memory, and an instruction from the cache, all in a single cycle.

Memory Interface

Addressing of external memory devices by the TSC21020F is facilitated by On-chip decoding of high-order address lines to generate memory bank select signals. Separate control lines are also generated for simplified addressing of page-mode DRAM. The TSC21020F provides programmable memory wait states, and external memory acknowledge controls allow interfacing to peripheral devices with variable access times.

Instruction Cache

The TSC21020F includes a high performance instruction cache that enables three-bus operation for fetching an instruction and two data values. The cache is selective-only the instructions whose fetches conflict with program memory data accesses are cached. This allows full-speed execution of core, looped operations such as digital filter multiply-accumulates and FFT butterfly processing.

Hardware Circular Buffers

The TSC21020F provides hardware to implement circular buffers in memory, which are common in digital filters and Fourier transform implementations. It handles address pointer wraparound, reducing overhead (thereby increasing performance) and simplifying implementation. Circular buffers can start and end at any location.

Flexible Instruction Set

The TSC21020F's 48-bit instruction word accommodates a variety of parallel operations, for concise programming. For example, the TSC21020F can conditionally execute a multiply, an add, a subtract and a branch in a single instruction.

1. It is fully compatible with Analog Devices ADSP-21020



Development System	The TSC21020F is supported with a complete set of software and hardware development tools from Analog Devices. The ADSP-21000 Family Development System from Analog Devices includes development software, an evaluation board and an in-circuit emulator.
Assembler	Creates relocatable, COFF (Common Object File Format) object files from ADSP-21xxx assembly source code. It accepts standard C preprocessor directives for conditional assembly and macro processing. The algebraic syntax of the ADSP-21xxx assembly language facilitates coding and debugging of DSP algorithms.
Linker/Librarian	The Linker processes separately assembled object files and library files to create a single executable program. It assigns memory locations to code and to data in accordance with a user-defined architecture file that describes the memory and I/O configuration of the target system. The Librarian allows you to group frequently used object files into a single library file that can be linked with your main program.
Simulator	The Simulator performs interactive, instruction-level simulation of ADSP-21xxx code within the hardware configuration described by a system architecture file. It flags illegal operations and supports full symbolic disassembly. It provides an easy-to-use, window oriented, graphical user interface that is identical to the one used by the ADSP- 21020 EZ-ICE Emulator. Commands are accessed from pull-down menus with a mouse.
PROM Splitter	Formats an executable file into files that can be used with an industry-standard PROM programmer.
C Compiler and Runtime Library	The C Compiler complies with ANSI specifications. It takes advantage of the TSC21020F's high-level language architectural features and incorporates optimizing algorithms to speed up the execution of code. It includes an extensive runtime library with over 100 standard and DSP-specific functions.
C Source Level Debugger	A full-featured C source level debugger that works with the simulator or EZ-ICE emulator to allow debugging of assembler source, C source, or mixed assembler and C.
Numerical C Compiler	Supports ANSI Standard (X3J11.1) Numerical C as defined by the Numeric C Extensions Group. The compiler accepts C source input containing Numerical C extensions for array selection, vector math operations, complex data types, circular pointers, and variably dimensioned arrays, and outputs ADSP-21xxx assembly language source code.
ADSP- 21020 EZ-LAB[®] Evaluation Board	The EZ-LAB Evaluation Board is a general-purpose, standalone TSC21020F system that includes 32K words of program memory and 32K words of data memory as well as analog I/O. A PC RS-232 download path enables the user to download and run programs directly on the EZ-LAB. In addition, it may be used in conjunction with the EZ-ICE Emulator to provide a powerful software debug environment.
ADSP- 21020 EZ-ICE[®] Emulator	This in-circuit emulator provides the system designer with a PC-based development environment that allows non-intrusive access to the TSC21020F's internal registers through the processor's 5-pin JTAG Test Access Port. This use of On-chip emulation circuitry enables reliable, full-speed performance in any target. The emulator uses the same graphical user interface as the ADSP- 21020 Simulator, allowing an easy transi-

tion from software to hardware debug. (See "Target System Requirements for Use of EZ-ICE Emulator" on page 27.)

®EZ-LAB and EZ-ICE are registered trademarks of Analog Devices, Inc.

Additional Information

This data sheet provides a general overview of TSC21020F functionality. For additional information on the architecture and instruction set of the processor, refer to the ADSP-21020 User's Manual. For development system and programming reference information, refer to the ADSP-21000 Family Development Software Manuals and the ADSP-21020 Programmer's Quick Reference.

Architecture Overview

Figure 1 shows a block diagram of the TSC21020F. The processor features:

- Three Computation Units (ALU, Multiplier, and Shifter) with a Shared Data Register File
- Two Data Address Generators (DAG 1, DAG 2)
- Program Sequencer with Instruction Cache
- 32-bit Timer
- Memory Buses and Interface
- JTAG Test Access Port and On-chip Emulation Support

Computation Units

The TSC21020F contains three independent computation units: an ALU, a multiplier with fixed-point accumulator, and a shifter. In order to meet a wide variety of processing needs, the computation units process data in three formats: 32-bit fixed-point, 32-bit floating-point and 40-bit floating-point. The floating-point operations are single-precision IEEE-compatible (IEEE Standard 754/854). The 32-bit floating-point format is the standard IEEE format, whereas the 40-bit IEEE extended-precision format has eight additional LSBs of mantissa for greater accuracy.

The multiplier performs floating-point and fixed-point multiplication as well as fixed-point multiply/add and multiply/subtract operations. Integer products are 64 bits wide, and the accumulator is 80 bits wide. The ALU performs 45 standard arithmetic and logic operations, supporting both fixed-point and floating-point formats. The shifter performs 19 different operations on 32-bit operands. These operations include logical and arithmetic shifts, bit manipulation, field deposit, and extract and derive exponent operations.

The computation units perform single-cycle operations; there is no computation pipeline. The three units are connected in parallel rather than serially, via multiple-bus connections with the 10-port data register file. The output of any computation unit may be used as the input of any unit on the next cycle. In a multifunction computation, the ALU and multiplier perform independent, simultaneous operations.

Data Register File

The TSC21020F's general-purpose data register file is used for transferring data between the computation units and the data buses, and for storing intermediate results. The register file has two sets (primary and alternate) of sixteen 40-bit registers each, for fast context switching.

Figure 1. TSC21020F Block Diagram

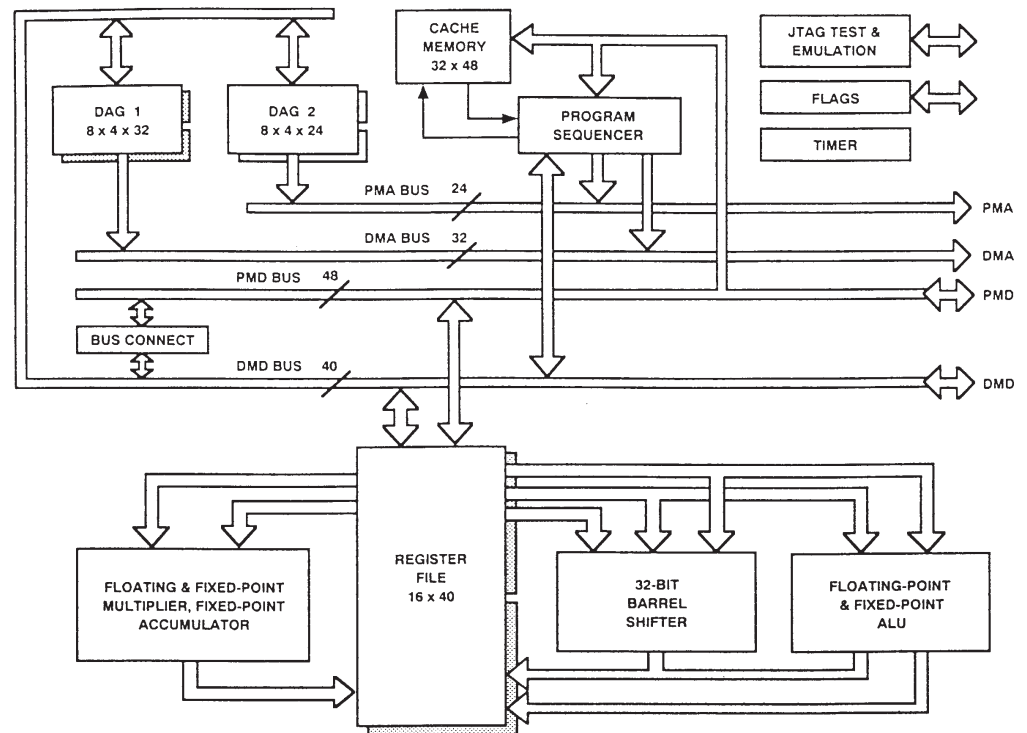

With a large number of buses connecting the registers to the computation units, data flow between computation units and from/to off-chip memory is unconstrained and free from bottlenecks. The 10-port register file and Harvard architecture of the TSC21020F allow the following nine data transfers to be performed every cycle:

- Off-chip read/write of two operands to or from the register file
- Two operands supplied to the ALU
- Two operands supplied to the multiplier
- Two results received from the ALU and multiplier (three, if the ALU operation is a combined addition/subtraction).

The processor's 48-bit orthogonal instruction word supports fully parallel data transfer and arithmetic operations in the same instruction.

Address Generators and Program Sequencer

Two dedicated address generators and a program sequencer supply addresses for memory accesses. Because of this, the computation units need never be used to calculate addresses. Because of its instruction cache, the TSC21020F can simultaneously fetch an instruction and data values from both off-chip program memory and off-chip data memory in a single cycle.

The data address generators (DAGs) provide memory addresses when external memory data is transferred over the parallel memory ports to or from internal registers. Dual data address generators enable the processor to output two simultaneous addresses for dual operand reads and writes. DAG 1 supplies 32-bit addresses to data memory. DAG 2 supplies 24-bit addresses to program memory for program memory data accesses.

Each DAG keeps track of up to eight address pointers, eight modifiers, eight buffer length values and eight base values. A pointer used for indirect addressing can be modified by a value in a specified register, either before (premodify) or after (post-modify)

the access. To implement automatic modulo addressing for circular buffers, the TSC21020F provides buffer length registers that can be associated with each pointer. Base values for pointers allow circular buffers to be placed at arbitrary locations. Each DAG register has an alternate register that can be activated for fast context switching.

The program sequencer supplies instruction addresses to program memory. It controls loop iterations and evaluates conditional instructions. To execute looped code with zero overhead, the TSC21020F maintains an internal loop counter and loop stack. No explicit jump or decrement instructions are required to maintain the loop.

The TSC21020F derives its high clock rate from pipelined fetch, decode and execute cycles. Approximately 70% of the machine cycle is available for memory accesses; consequently, TSC21020F systems can be built using slower and therefore less expensive memory chips.

Instruction Cache

The program sequencer includes a high performance, selective instruction cache that enables three-bus operation for fetching an instruction and two data values. This two-way, set-associative cache holds 32 instructions. The cache is selective (only the instructions whose fetches conflict with program memory data accesses are cached), so the TSC21020F can perform a program memory data access and can execute the corresponding instruction in the same cycle. The program sequencer fetches the instruction from the cache instead of from program memory, enabling the TSC21020F to simultaneously access data in both program memory and data memory.

Context Switching

Many of the TSC21020F's registers have alternate register sets that can be activated during interrupt servicing to facilitate a fast context switch. The data registers in the register file, DAG registers and the multiplier result register all have alternate sets. Registers active at reset are called primary registers; the others are called alternate registers. Bits in the MODE1 control register determine which registers are active at any particular time.

The primary/alternate select bits for each half of the register file (top eight or bottom eight registers) are independent. Likewise, the top four and bottom four register sets in each DAG have independent primary/alternate select bits. This scheme allows passing of data between contexts.

Interrupts

The TSC21020F has four external hardware interrupts, nine internally generated interrupts, and eight software interrupts. For the external interrupts and the internal timer interrupt, the TSC21020F automatically stacks the arithmetic status and mode (MODE1) registers when servicing the interrupt, allowing five nesting levels of fast service for these interrupts.

An interrupt can occur at any time while the TSC21020F is executing a program. Internal events that generate interrupts include arithmetic exceptions, which allow for fast trap handling and recovery.

Timer

The programmable interval timer provides periodic interrupt generation. When enabled, the timer decrements a 32-bit count register every cycle. When this count register reaches zero, the TSC21020F generates an interrupt and asserts its TIMEXP output. The count register is automatically reloaded from a 32-bit period register and the count resumes immediately.

System Interface

Figure 2 shows an TSC21020F basic system configuration.

The external memory interface supports memory-mapped peripherals and slower memory with a user-defined combination of programmable wait states and hardware acknowledge signals. Both the program memory and data memory interfaces support addressing of page-mode DRAMs.

The TSC21020F's internal functions are supported by four internal buses: the program memory address (PMA) and data memory address (DMA) buses are used for addresses associated with program and data memory. The program memory data (PMD) and data memory data (DMD) buses are used for data associated with the two memory spaces. These buses are extended off chip. Four data memory select (DMS) signals select one of four user-configurable banks of data memory. Similarly, two program memory select (PMS) signals select between two user-configurable banks of program memory. All banks are independently programmable for 0-7 wait states.

The PX registers permit passing data between program memory and data memory spaces. They provide a bridge between the 48-bit PMD bus and the 40-bit DMD bus or between the 40-bit register file and the PMD bus.

The PMA bus is 24 bits wide allowing direct access of up to 16M words of mixed instruction code and data. The PMD is 48 bits wide to accommodate the 48-bit instruction width. For access of 40-bit data the lower 8 bits are unused. For access of 32-bit data the lower 16 bits are ignored.

The DMA bus is 32 bits wide allowing direct access of up to 4 Gigawords of data. The DMD bus is 40 bits wide. For 32-bit data, the lower 8 bits are unused. The DMD bus provides a path for the contents of any register in the processor to be transferred to any other register or to any external data memory location in a single cycle. The data memory address comes from one of two sources: an absolute value specified in the instruction code (direct addressing) or the output of a data address generator (indirect addressing).

Figure 2. Basic System Configuration

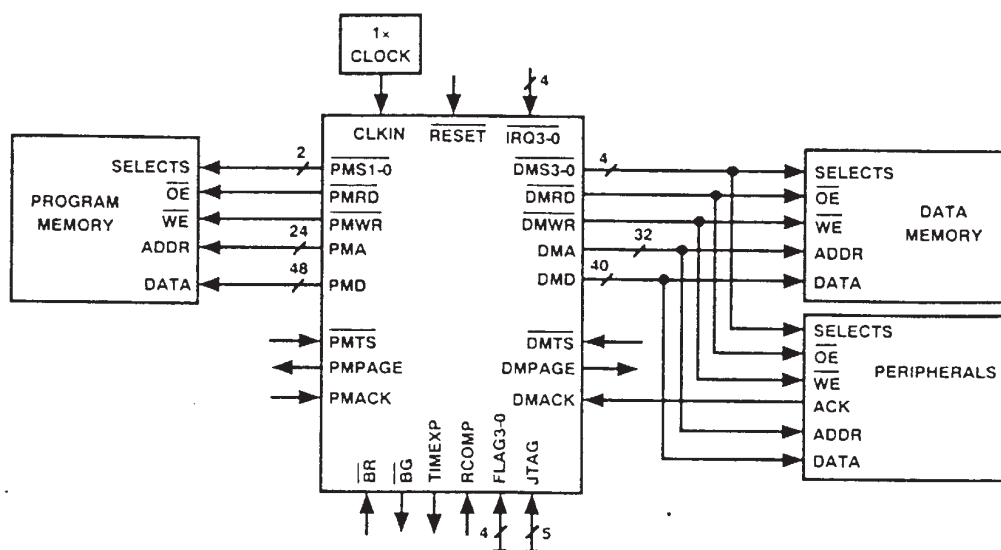

External devices can gain control of the processor's memory buses from the TSC21020F by means of the bus request/grant signals (BR and BG). To grant its buses in response to a bus request, the TSC21020F halts internal operations and places its



program and data memory interfaces in a high impedance state. In addition, three-state controls (DTMS and PMTS) allow an external device to place either the program or data memory interface in a high impedance state without affecting the other interface and without halting the TSC21020F unless it requires a memory access from the affected interface. The three-state controls make it easy for an external cache controller to hold the TSC21020F off the bus while it updates an external cache memory.

JTAG Test and Emulation Support

The TSC21020F implements the boundary scan testing provisions specified by IEEE Standard 1149.1 of the Joint Testing Action Group (JTAG). The TSC21020F's test access port and On-chip JTAG circuitry is fully compliant with the IEEE 1149.1 specification. The test access port enables boundary scan testing of circuitry connected to the TSC21020F's I/O pins.

The TSC21020F also implements On-chip emulation through the JTAG test access port. The processor's eight sets of breakpoint range registers enable program execution at full speed until reaching a desired breakpoint address range. The processor can then halt and allow reading/writing of all the processor's internal registers and external memories through the JTAG port.

Pin Descriptions

This section describes the pins of the TSC21020F. When groups of pins are identified with subscripts, e.g. PMD_{47-0} , the highest numbered pin is the MSB (in this case, PMD_{47}). Inputs identified as synchronous (S) must meet timing requirements with respect to CLKIN (or with respect to TCK for TMS, TDI, and TRST). Those that are asynchronous (A) can be asserted asynchronously to CLKIN.

Note: O = Output; I = Input; S = Synchronous; A = Asynchronous; P = Power Supply; G = Ground.

Pin Name	Type	Function
PMA_{23-0}	O	Program Memory Address. The TSC21020F outputs an address in program memory on these pins.
PMD_{47-0}	I/O	Program Memory Data. The TSC21020F inputs and outputs data and instructions on these pins. 32-bit fixed-point data and 32-bit single-precision floating-point data is transferred over bits 47-16 of the PMD bus.
PMS_{1-0}	O	Program Memory Select lines. These pins are asserted as chip selects for the corresponding banks of program memory. Memory banks must be defined in the memory control registers. These pins are decoded program memory address lines and provide an early indication of a possible bus cycle.
PMRD	O	Program Memory Read strobe. This pin is asserted when the TSC21020F reads from program memory.
PMWR	O	Program Memory Write strobe. This pin is asserted when the TSC21020F writes to program memory.
PMACK	I/S	Program Memory Acknowledge. An external device de-asserts this input to add wait states to a memory access.
PMPAGE	O	Program Memory Page Boundary. The TSC21020F asserts this pin to signal that a program memory page boundary has been crossed. Memory pages must be defined in the memory control registers.
PMTS	I/S	Program Memory Three-State Control. PMTS places the program memory address, data, selects, and strobes in a high-impedance state. If PMTS is asserted while a PM access is occurring, the processor will halt and the memory access will not be completed. PMACK must be asserted for at least one cycle when PMTS is de-asserted to allow any pending memory access to complete properly. PMTS should only be asserted (low) during an active memory access cycle.
DMA_{31-0}	O	Data Memory Address. The TSC21020F outputs an address in data memory on these pins.
DMD_{39-0}	I/O	Data Memory Data. The TSC21020F inputs and outputs data on these pins. 32-bit fixed-point data and 32-bit single-precision floating-point data is transferred over bits 39-8 of the DMD bus.
DMS_{3-0}	O	Data Memory Select lines. These pins are asserted as chip selects for the corresponding banks of data memory. Memory banks must be defined in the memory control registers. These pins are decoded data memory address lines and provide an early indication of a possible bus cycle.

Pin Name	Type	Function
DMRD	O	Data Memory Read strobe. This pin is asserted when the TSC21020F reads from data memory.
DMWR	O	Data Memory Write strobe. This pin is asserted when the TSC21020F writes to data memory.
DMACK	I/S	Data Memory Acknowledge. An external device de-asserts this input to add wait states to a memory access.
DMPAGE	O	Data Memory Page Boundary. The TSC21020F asserts this pin to signal that a data memory page boundary has been crossed. Memory pages must be defined in the memory control registers.
DMTS	I/S	Data Memory Three-State Control. DMTS places the data memory address, data, selects, and strobes in a high-impedance state. If DMTS is asserted while a DM access is occurring, the processor will halt and the memory access will not be completed. DMACK must be asserted for at least one cycle when DMTS is de-asserted to allow any pending memory access to complete properly. DMTS should only be asserted (low) during an active memory access cycle.
CLKIN	I	External clock input to the TSC21020F. The instruction cycle rate is equal to CLKIN. CLKIN may not be halted, changed, or operated below the specified frequency.
RESET	I/A	Sets the TSC21020F to a known state and begins execution at the program memory location specified by the hardware reset vector (address). This input must be asserted (low) at power-up.
IRQ ₃₋₀	I/A	Interrupt request lines; may be either edge-triggered or level-sensitive.
FLAG ₃₋₀	I/O/A	External Flags. Each is configured via control bits as either an input or output. As an input, it can be tested as a condition. As an output, it can be used to signal external peripherals.
BR	I/A	Bus Request. Used by an external device to request control of the memory interface. When BR is asserted, the processor halts execution after completion of the current cycle, places all memory data, addresses, selects, and strobes in a high-impedance state, and asserts BG. The processor continues normal operation when BR is released.
BG	O	Bus Grant. Acknowledges a bus request (BR), indicating that the external device may take control of the memory interface. BG is asserted (held low) until BR is released.
TIMEXP	O	Timer Expired. Asserted for four cycles when the value of TCOUNT is decremented to zero.
RCOMP		Not available Can be set to any voltage level.
EVDD	P	Power supply (for output drivers), nominally + 5V dc (10 pins).
EGND	G	Power supply return (for output drivers); (16 pins).
IVDD	P	Power supply (for internal circuitry), nominally + 5V dc (4 pins).
IGND	G	Power supply return (for internal circuitry); (7 pins).

Pin Name	Type	Function
TCK	I	Test Clock. Provides an asynchronous clock for JTAG boundary scan.
TMS	I/S	Test Mode Select. Used to control the test state machine. TMS has a 20 kΩ internal pull-up resistor.
TDI	I/S	Test Data Input. Provides serial data for the boundary scan logic. TDI has a 20 kΩ internal pull-up resistor.
TDO	O	Test Data Output. Serial scan output of the boundary scan path.
TRST	I/A	Test Reset. Resets the test state machine. TRST must be asserted (pulsed low) after power-up or held low for proper operation of the TSC21020F. TRST has a 20 kΩ internal pull-up resistor.
NC		No Connect. No Connects are reserved pins that must be left open and unconnected.

Table 1. PGA Pin Configuration

PGA Location	Pin Name	PGA Location	Pin Name	PGA Location	Pin Name	PGA Location	Pin Name
G16	DMA0	B5	DMD25	K1	PMD9	L16	TIMEXP
G17	DMA1	B6	DMD26	L3	PMD10	U12	RCOMP
F18	DMA2	D6	DMD27	L2	PMD11	T11	CLKIN
F17	DMA3	C6	DMD28	M1	PMD12	T14	TRST
F16	DMA4	A8	DMD29	M2	PMD13	R12	TD0
F15	DMA5	C7	DMD30	M3	PMD14	S13	TDI
E18	DMA6	D7	DMD31	M4	PMD15	U16	TMS
E17	DMA7	B7	DMD32	N2	PMD16	U14	TCK
E16	DMA8	B8	DMD33	N3	PMD17	H18	EGND
D18	DMA9	A10	DMD34	P1	PMD18	A3	EGND
E15	DMA10	C8	DMD35	P2	PMD19	A7	EGND
D17	DMA11	D8	DMD36	N4	PMD20	A11	EGND
D16	DMA12	B9	DMD37	S1	PMD21	A15	EGND
C18	DMA13	C9	DMD38	P3	PMD22	E1	EGND
C17	DMA14	B10	DMD39	R2	PMD23	G1	EGND
D15	DMA15	D10	DMS0	P4	PMD24	L1	EGND
B18	DMA16	C11	DMS1	R3	PMD25	L18	EGND
B17	DMA17	A12	DMS2	S2	PMD26	R1	EGND
C16	DMA18	B11	DMS3	T1	PMD27	R18	EGND
D14	DMA19	T13	DMWR	S3	PMD28	T18	EGND
C15	DMA20	S11	DMRD	R4	PMD29	U5	EGND
B16	DMA21	B12	DMPAGE	T2	PMD30	U7	EGND

Table 1. PGA Pin Configuration (Continued)

PGA Location	Pin Name	PGA Location	Pin Name	PGA Location	Pin Name	PGA Location	Pin Name
A16	DMA22	S12	DMTS	U1	PMD31	U11	EGND
D13	DMA23	T12	DMACK	T3	PMD32	U15	EGND
C14	DMA24	L17	PMA0	R5	PMD33	D11	IGND
B15	DMA25	M18	PMA1	S4	PMD34	G4	IGND
B14	DMA26	M15	PMA2	U2	PMD35	G15	IGND
D12	DMA27	M16	PMA3	S5	PMD36	L4	IGND
C13	DMA28	M17	PMA4	T4	PMD37	L15	IGND
A14	DMA29	N17	PMA5	R6	PMD38	R7	IGND
B13	DMA30	N16	PMA6	U3	PMD39	R11	IGND
C12	DMA31	N15	PMA7	U4	PMD40	A5	EVDD
H3	DMD0	P18	PMA8	S6	PMD41	A9	EVDD
H4	DMD1	P17	PMA9	T6	PMD42	A13	EVDD
E2	DMD2	R17	PMA10	S7	PMD43	J1	EVDD
G3	DMD3	S18	PMA11	U6	PMD44	J18	EVDD
D1	DMD4	P15	PMA12	T7	PMD45	N1	EVDD
D2	DMD5	P16	PMA13	R8	PMD46	N18	EVDD
F3	DMD6	S17	PMA14	S8	PMD47	U9	EVDD
C1	DMD7	R16	PMA15	R13	PMS0	U13	EVDD
C2	DMD8	R15	PMA16	T15	PMS1	K18	EVDD
F4	DMD9	U18	PMA17	U8	PMWR	D9	IVDD
E3	DMD10	S16	PMA18	S9	PMRD	J4	IVDD
D3	DMD11	T17	PMA19	S14	PMPAGE	J15	IVDD
B1	DMD12	U17	PMA20	T8	PMTS	R9	IVDD
E4	DMD13	R14	PMA21	U10	PMACK	C10	NC
B2	DMD14	S15	PMA22	A17	BG	S10	NC
C3	DMD15	T16	PMA23	A18	BR	T10	NC
A2	DMD16	F2	PMD0	H16	FLAG0	T9	NC
D4	DMD17	F1	PMD1	H15	FLAG1	K17	NC
B3	DMD18	J3	PMD2	H17	FLAG2	T5	NC
A4	DMD19	H2	PMD3	G18	FLAG3	G2	NC
C4	DMD20	H1	PMD4	J17	IRQ0		
B4	DMD21	J2	PMD5	J16	IRQ1		
D5	DMD22	K4	PMD6	K16	IRQ2		
A6	DMD23	K3	PMD7	K15	IRQ3		
C5	DMD24	K2	PMD8	R10	RESET		

Table 2. MQFP Pin Configuration

MQFP_F Location	Pin Name	MQFP_F Location	Pin Name	MQFP_F Location	Pin Name	MQFP_F Location	Pin Name
1	IGND	65	IGND	129	IGND	193	IGND
2	IVDD	66	IVDD	130	IVDD	194	IVDD
3	DMD19	67	PMD25	131	PMA19	195	DMA15
4	DMD18	68	PMD26	132	PMA18	196	EGND
5	DMD17	69	PMD27	133	PMA17	197	DMA16
6	DMD16	70	EVDD	134	PMA16	198	DMA17
7	EGND	71	PMD28	135	EGND	199	DMA18
8	DMD15	72	PMD29	136	PMA15	200	DMA19
9	DMD14	73	PMD30	137	PMA14	201	EVDD
10	DMD13	74	PMD31	138	PMA13	202	DMA20
11	DMD12	75	EGND	139	PMA12	203	DMA21
12	EVDD	76	PMD32	140	EVDD	204	DMA22
13	DMD11	77	PMD33	141	PMA11	205	DMA23
14	DMD10	78	PMD34	142	PMA10	206	EGND
15	DMD9	79	PMD35	143	PMA9	207	DMA24
16	DMD8	80	EVDD	144	PMA8	208	DMA25
17	IGND	81	IGND	145	IGND	209	IGND
18	IVDD	82	IVDD	146	IVDD	210	IVDD
19	EGND	83	PMD36	147	EGND	211	DMA26
20	DMD7	84	PMD37	148	PMA7	212	DMA27
21	DMD6	85	PMD38	149	PMA6	213	EVDD
22	DMD5	86	PMD39	150	PMA5	214	DMA28
23	DMD4	87	EGND	151	PMA4	215	DMA29
24	EVDD	88	PMD40	152	EVDD	216	DMA30
25	DMD3	89	PMD41	153	PMA3	217	DMA31
26	DMD2	90	PMD42	154	PMA2	218	EGND
27	DMD1	91	PMD43	155	PMA1	219	DMPAGE
28	DMD0	92	EVDD	156	PMA0	220	BR
29	EGND	93	PMD44	157	EGND	221	BG
30	PMD0	94	PMD45	158	TIMEXP	222	DMS0
31	PMD1	95	PMD46	159	EVDD	223	DMS1
32	PMD2	96	PMD47	160	EGND	224	EVDD
33	IGND	97	IGND	161	IGND	225	IGND
34	IVDD	98	IVDD	162	IVDD	226	IVDD
35	PMD3	99	EGND	163	IRQ3	227	DMS2

Table 2. MQFP Pin Configuration (Continued)

MQFP_F Location	Pin Name	MQFP_F Location	Pin Name	MQFP_F Location	Pin Name	MQFP_F Location	Pin Name
36	EVDD	100	PMTS	164	IRQ2	228	DMS3
37	PMD4	101	PMWR	165	IRQ1	229	DMD39
38	PMD5	102	PMACK	166	IRQ0	230	DMD38
39	PMD6	103	PMRD	167	EVDD	231	EGND
40	PMD7	104	RCMP	168	FLAG0	232	DMD37
41	EGND	105	EVDD	169	FLAG1	233	DMD36
42	PMD8	106	RESET	170	FLAG2	234	DMD35
43	PMD9	107	CLKIN	171	FLAG3	235	DMD34
44	PMD10	108	DMRD	172	EGND	236	EVDD
45	PMD11	109	DMACK	173	DMA0	237	DMD33
46	EVDD	110	DMWR	174	DMA1	238	DMD32
47	PMD12	111	EVDD	175	DMA2	239	DMD31
48	PMD13	112	DMTS	176	DMA3	240	DMD30
49	IGND	113	IGND	177	IGND	241	IGND
50	IVDD	114	IVDD	178	IVDD	242	IVDD
51	PMD14	115	TCK	179	EVDD	243	EGND
52	PMD15	116	TMS	180	DMA4	244	DMD29
53	EGND	117	TDI	181	DMA5	245	DMD28
54	PMD16	118	TDO	182	DMA6	246	DMD27
55	PMD17	119	TRST	183	DMA7	247	DMD26
56	PMD18	120	PMPAGE	184	EGND	248	EVDD
57	PMD19	121	PMS0	185	DMA8	249	DMD25
58	EVDD	122	PMS1	186	DMA9	250	DMD24
59	PMD20	123	EGND	187	DMA10	251	DMD23
60	PMD21	124	PMA23	188	DMA11	252	EGND
61	PMD22	125	PMA22	189	EVDD	253	DMD22
62	PMD23	126	PMA21	190	DMA12	254	DMD21
63	EGND	127	PMA20	191	DMA13	255	DMD20
64	PMD24	128	EVDD	192	DMA14	256	EVDD

Instruction Set Summary

The TSC21020F instruction set provides a wide variety of programming capabilities. Every instruction assembles into a single word and can execute in a single processor cycle. Multifunction instructions enable simultaneous multiplier and ALU operations, as well as computations executed in parallel with data transfers. The addressing power of the TSC21020F gives flexibility in moving data both internally and externally. The TSC21020F assembly language uses an algebraic syntax for ease of coding and readability.

The instruction types are grouped into four categories:

- Compute and Move or Modify
- Program Flow Control
- Immediate Move
- Miscellaneous

The instruction types are numbered; there are 22 types. Some instructions have more than one syntactical form; for example, Instruction 4 has four distinct forms. The instruction number itself has no bearing on programming, but corresponds to the opcode recognized by the TSC21020F device.

Because of the width and orthogonality of the instruction word, there are many possible instructions. For example, the ALU supports 21 fixed-point operations and 24 floating-point operations; each of these operations can be the compute portion of an instruction.

The following pages provide an overview and summary of the TSC21020F instruction set. For complete information, see the ADSP-21020 User's Manual from Analog Devices. For additional reference information, see the ADSP-21020 Programmer's Quick Reference from Analog Devices.

This section also contains several reference tables for using the instruction set.

- Table 3 describes the notation and abbreviations used.
- Table 4 lists all condition and termination code mnemonics.
- Table 5 lists all register mnemonics.
- Table 6 through 9 list the syntax for all compute (ALU, multiplier, shifter or multifunction) operations.
- Table 10 lists interrupts and their vector addresses.

Compute and Move or Modify Instructions

1. compute, $\left| \begin{array}{l} DM(la, Mb) = dreg1 \\ dreg1 = DM(la, Mb) \end{array} \right| \quad \left| \begin{array}{l} PM(lc, Md) = dreg2 \\ dreg2 = PM(lc, Md) \end{array} \right|$
2. *IF condition* compute ;
- 3a. *IF condition* compute, $\left| \begin{array}{l} DM(Mb, la) \\ PM(lc, Md) \end{array} \right| = ureg ;$
- 3b. *IF condition* compute, $\left| \begin{array}{l} DM(Mb, la) \\ PM(Md, lc) \end{array} \right| = ureg ;$
- 3c. *IF condition* compute, $ureg = \left| \begin{array}{l} DM(la, Mb) \\ PM(lc, Md) \end{array} \right| ;$
- 3d. *IF condition* compute, $ureg = \left| \begin{array}{l} DM(Mb, la) \\ PM(Md, lc) \end{array} \right| ;$
- 4a. *IF condition* compute, $\left| \begin{array}{l} DM(la, < data6 >) \\ PM(lc, < data6 >) \end{array} \right| = dreg ;$
- 4b. *IF condition* compute, $\left| \begin{array}{l} DM(la, < data6 >, la) \\ PM(lc, < data6 >, lc) \end{array} \right| = dreg ;$
- 4c. *IF condition* compute, $dreg = \left| \begin{array}{l} DM(Mb, la) \\ PM(Md, lc) \end{array} \right|$
- 4d. *IF condition* compute, $dreg = \left| \begin{array}{l} DM(la, < data6 >, la) \\ PM(lc, < data6 >, lc) \end{array} \right|$
5. *IF condition* compute, $ureg1 = ureg2 ;$
- 6a. *IF condition* shiftimm, $\left| \begin{array}{l} DM(la, Mb) \\ PM(lc, Md) \end{array} \right| = dreg ;$
- 6b. *IF condition* shiftimm, $\left| \begin{array}{l} DM(la, Mb) \\ PM(lc, Md) \end{array} \right| = dreg ;$
7. *IF condition* compute, MODIFY $\left| \begin{array}{l} DM(la, Mb) \\ PM(lc, Md) \end{array} \right| ;$

Program Flow Control Instructions

8. *IF condition* $\left| \begin{array}{l} JUMP \\ CALL \end{array} \right| \left| \begin{array}{l} < addr24 > \\ (PC, < reladdr24 >) \end{array} \right| \left| \begin{array}{l} (DB) \\ LA \\ DB, LA \end{array} \right| ;$
9. *IF condition* $\left| \begin{array}{l} JUMP \\ CALL \end{array} \right| \left| \begin{array}{l} < Md, lc > \\ (PC, < reladdr6 >) \end{array} \right| \left| \begin{array}{l} (DB) \\ LA \\ DB, LA \end{array} \right| ;$
11. *IF condition* $\left| \begin{array}{l} RTS \\ RTI \end{array} \right| \left| \begin{array}{l} (DB) \\ LA \\ DB, LA \end{array} \right|, compute ;$
12. LCNTR = $\left| \begin{array}{l} < data16 > \\ ureg \end{array} \right|, DO \left| \begin{array}{l} < addr24 > \\ (PC, < reladdr24 >) \end{array} \right| UNTIL LCE;$
13. DO $\left| \begin{array}{l} < addr24 > \\ (PC, < reladdr24 >) \end{array} \right| UNTIL termination;$

Note: DB = Delayed Branch
LA = Loop abort (pop loop PC stacks on branch)

Immediate Move Instructions

- 14a. $\left| DM < addr32 > \right| = ureg ;$

Table 3. Syntax Notation Conventions

Notation	Meaning
ureg	Universal register (from Table 3)
sreg	System register (from Table 3)
dreg	R15-R0, F15-F0; register file location
la	I7-I0; DAG1 index register
Mb	M7-M0; DAG1 modify register
lc	I15-I8; DAG2 index register
Md	M15-M8; DAG2 modify register

Table 4. Condition and Termination Codes

Name	Description
eq	ALU equal to zero
ne	ALU not equal to zero
ge	ALU greater than or equal to zero
lt	ALU less than zero
le	ALU less than or equal to zero
gt	ALU greater than zero
ac	ALU carry
not ac	Not ALU carry
av	ALU overflow
not av	Not ALU overflow
mv	Multiplier overflow
not mv	Not multiplier overflow
ms	Multiplier sign
not ms	Not multiplier sign
sv	Shifter overflow
not sv	Not shifter overflow
sz	Shifter zero
not sz	Not shifter zero
flag0_in	Flag 0
not flag0_in	Not Flag 0
flag1_in	Flag 1
not flag1_in	Not Flag 1
flag2_in	Flag 2
not flag2_in	Not Flag 2
flag3_in	Flag 3
not flag3_in	Not Flag 3
tf	Bit test flag
not tf	Not bit test flag
lce	Loop counter expired (DO UNTIL)
not lce	Loop counter not expired (IF)
forever	Always False (DO UNTIL)
true	Always True (IF)

Note: In a conditional instruction, the execution of the entire instruction is based on the specified condition.

Table 5. Universal Registers

Name	Function
Register file	
R15-R0	Register file locations
Program Sequencer	
PC ⁽¹⁾	Program counter; address of instruction currently executing
PCSTK	Top of PC stack
PCSTKP	PC stack pointer
FADDR ⁽¹⁾	Fetch address
DADDR ⁽¹⁾	Decode address
LADDR	Loop termination address, code; top of loop address stack
CURLCNTR	Current loop counter; top of loop count stack
LCNTR	Loop count for next nested counter-controlled loop
Data Address Generators	
I7-I0	DAG1 index registers
M7-M0	DAG1 modify registers
L7-L0	DAG1 length registers
B7-B0	DAG1 base registers
I15-I8	DAG2 index registers
M15-M8	DAG2 modify registers
L15-L8	DAG2 length registers
B15-B8	DAG2 base registers
Bus Exchange	
PX1	PMD-DMD bus exchange 1 (16 bits)
PX2	PMD-DMD bus exchange 2 (32 bits)
PX	48-bit PX1 and PX2 combination
Timer	
TPERIOD	Timer period
TCOUNT	Timer counter
Memory Interface	
DMWAIT	Wait state and page size control for data memory
DMBANK1	Data memory bank 1 upper boundary
DMBANK2	Data memory bank 2 upper boundary

Table 5. Universal Registers (Continued)

Name	Function
DMBANK3	Data memory bank 3 upper boundary
DMADR ⁽¹⁾	Copy of last data memory address
PMWAIT	Wait state and page size control for program memory
PMBANK1	Program memory bank 1 upper boundary
PMADR ⁽¹⁾	Copy of last program memory address
System Register	
MODE1	Mode control bits for bit-reverse, alternate registers, interrupt nesting and enable, ALU saturation, floating-point rounding mode and boundary
MODE2	Mode control bits for interrupt sensitivity, cache disable and freeze, timer enable, and I/O flag configuration
IRPTL	Interrupt latch
IMASK	Interrupt mask
IMASKP	Interrupt mask pointer (for nesting)
ASTAT	Arithmetic status flags, bit test, I/O flag values, and compare accumulator
STKY	Sticky arithmetic status flags, circular buffer overflow flags, stack status flags (not sticky)
USTAT1	User status register 1
USTAT2	User status register 2

Note: 1. Read-only
Refer to User's Manual for bit-level definitions of each register.

Table 6. ALU Compute Operations

Fixed-Point	Floating-Point
$R_n = R_x + R_y$	$F_n = F_x + F_y$
$R_n = R_x - R_y$	$F_n = F_x - F_y$
$R_n = R_x + R_y, R_m = R_x - R_y$	$F_n = F_x + F_y, F_m = F_x - F_y$
$R_n = R_x + R_y + C_i$	$F_n = \text{ABS}(F_x + F_y)$
$R_n = R_x - R_y + C_i - 1$	$F_n = \text{ABS}(F_x - F_y)$
$R_n = (R_x + R_y)/2$	$F_n = (F_x + F_y)/2$
COMP(R_x, R_y)	COMP(F_x, F_y)
$R_n = -R_x$	$F_n = -F_x$
$R_n = \text{ABS } R_x$	$F_n = \text{ABS } F_x$
$R_n = \text{PASS } R_x$	$F_n = \text{PASS } F_x$
$R_n = \text{MIN}(R_x, R_y)$	$F_n = \text{MIN}(F_x, F_y)$
$R_n = \text{MAX}(R_x, R_y)$	$F_n = \text{MAX}(F_x, F_y)$

Table 6. ALU Compute Operations (Continued)

Fixed-Point	Floating-Point
$R_n = \text{CLIP } R_x \text{ BY } R_y$	$F_n = \text{CLIP } F_x \text{ BY } F_y$
$R_n = R_x + \text{CI}$	$F_n = \text{RND } F_x$
$R_n = R_x + \text{CI} - 1$	$F_n = \text{SCALB } F_x \text{ BY } R_y$
$R_n = R_x + 1$	$R_n = \text{MANT } F_x$
$R_n = R_x - 1$	$R_n = \text{LOGB } F_x$
$R_n = R_x \text{ AND } R_y$	$R_n = \text{FIX } F_x \text{ BY } R_y$
$R_n = R_x \text{ OR } R_y$	$R_n = \text{FIX } F_x$
$R_n = R_x \text{ XOR } R_y$	$F_n = \text{FLOAT } R_x \text{ BY } R_y$
$R_n = \text{NOT } R_x$	$F_n = \text{FLOAT } R_x$
	$F_n = \text{RECIPS } F_x$
	$F_n = \text{RSQRTS } F_x$
	$F_n = F_x \text{ COPYSIGN } F_y$

Note: R_n, R_x, R_y R15-R0; register file location, fixed-point
 F_n, F_x, F_y F15-F0; register file location, floating point

Multiplier Compute Operations

$$\begin{array}{l}
 R_n = R_x * R_y \left(\begin{array}{c|c|c} S & S & F \\ \hline U & U & I \\ \hline & & FR \end{array} \right) \\
 MRF \\
 MRB
 \end{array}
 \qquad
 F_n = F_x * F_y$$

$$\begin{array}{l}
 \left| \begin{array}{l} R_n = MR_F + R_x * R_y \\ R_n = MR_B \\ MRF = MR_F \\ MRB = MR_B \end{array} \right| \begin{array}{c|c|c} S & S & F \\ \hline U & U & I \\ \hline & & FR \end{array} \\
 \left| \begin{array}{l} R_n = SAT MRF \\ R_n = SAT MRB \\ MRF = SAT MRF \\ MRB = SAT MRB \end{array} \right| \begin{array}{c} (SI) \\ (UI) \\ (SF) \\ (UF) \end{array}
 \end{array}
 \qquad
 \begin{array}{l}
 \left| \begin{array}{l} R_n = MR_F \\ R_n = MR_B \\ MRF = MR_F \\ MRB = MR_B \end{array} \right| R_x * R_y \begin{array}{c|c|c} S & S & F \\ \hline U & U & I \\ \hline & & FR \end{array} \\
 \left| \begin{array}{l} R_n = RND MRF \\ R_n = RND MRB \\ MRF = RND MRF \\ MRB = RND MRB \end{array} \right| \begin{array}{c} (SF) \\ (UF) \end{array}
 \end{array}$$

$$\begin{array}{l}
 \left| \begin{array}{l} MRF \\ MRB \end{array} \right| = 0 \\
 \left| \begin{array}{l} MRxF \\ MRxB \end{array} \right| = R_n
 \end{array}
 \qquad
 R_n = \left| \begin{array}{l} MRxF \\ MRxB \end{array} \right|$$

Rn, Rx, Ry R15-R0; register file location, fixed-point
 Fn, Fx, Fy F15-F0; register file location, floating-point
 MRxF MR2F, MR1F, MR0F; multiplier result accumulators, foreground
 MRxB MR2B, MR1B, MR0B; multiplier result accumulators, background

(|x-input| |y-input| |data format|
 | rounding |

S Signed input
 U Unsigned input
 I Integer input(s)
 F Fractional input(s)
 FR Fractional inputs, Rounded output
 (SF) Default format for 1-input operations
 (SSF) Default format for 2-input operations

Table 7. Shifter and Shifter Immediate Compute Operations

Shifter	Shifter Immediate
Rn = LSHIFT Rx BY Ry	
Rn = Rn OR LSHIFT Rx BY Ry	
Rn = ASHIFT Rx BY Ry	
Rn = Rn OR ASHIFT Rx BY Ry	
Rn = ROT Rx BY RY	Rn = LSHIFT Rx BY<data8>
Rn = BCLR Rx BY Ry	Rn = Rn OR LSHIFT Rx BY<data8>
Rn = BSET Rx BY Ry	Rn = ASHIFT Rx BY<data8>
Rn = BTGL Rx BY Ry	Rn = Rn OR ASHIFT Rx BY<data8>
BTST Rx BY Ry	Rn = ROT Rx BY<data8>
Rn = FDEP Rx BY Ry	Rn = BCLR Rx BY<data8>
Rn = Rn OR FDEP Rx BY Ry	Rn = BSET Rx BY<data8>
Rn = FDEP Rx BY Ry (SE)	Rn = BTGL Rx BY<data8>
Rn = Rn OR FDEP Rx BY Ry (SE)	BTST Rx BY<data8>
Rn = FEXT Rx BY Ry	Rn = FDEP Rx BY <bit6>: <len6>
Rn = FEXT Rx BY Ry (SE)	Rn = Rn OR FDEP Rx BY <bit6>: <len6>
Rn = EXP Rx	Rn = FDEP Rx BY <bit6>: <len6> (SE)
Rn = EXP Rx (EX)	Rn = Rn OR FDEP Rx BY (bit6): <len6> (SE)
Rn = LEFTZ Rx	Rn = FEXT Rx BY <bit6>: <len6>
Rn = LEFTO Rx	Rn = FEXT Rx BY <bit6>: <len6> (SE)

Note: Rn, Rx, Ry R15-R0; register file location, fixed-point

<bit6>: <len6> 6-bit immediate bit position and length values (for shifter immediate operations)

Table 8. Multifunction Compute Operations

Fixed-Point
$Rm = R3-0^{(1)} R7-4$ (SSFR), $Ra = R11-8 + R15-12$
$Rm = R3-0^{(1)} R7-4$ (SSFR), $Ra = R11-8 - R15-12$
$Rm = R3-0^{(1)} R7-4$ (SSFR), $Ra = (R11-8 + R15-12)/2$
$MRF = MRF + R3-0^{(1)} R7-4$ (SSF), $Ra = R11-8 + R15-12$
$MRF = MRF + R3-0^{(1)} R7-4$ (SSF), $RA = R11-8 - R15-12$
$MRF = MRF + R3-0^{(1)} R7-4$ (SSF), $Ra = (R11-8 + R15-12)/2$
$Rm = MRF + R3-0^{(1)} R7-4$ (SSFR), $Ra = R11-8 + R15-12$
$Rm = MRF + R3-0^{(1)} R7-4$ (SSFR), $Ra = R11-8 - R15-12$
$Rm = MRF + R3-0^{(1)} R7-4$ (SSFR), $Ra = (R11-8 + R15-12)/2$
$MRF = MRF - R3-0^{(1)} R7-4$ (SSF), $Ra = R11-8 + R15-12$
$MRF = MRF - R3-0^{(1)} R7-4$ (SSF), $Ra = R11-8 - R15-12$
$MRF = MRF - R3-0^{(1)} R7-4$ (SSF), $Ra = (R11-8 + R15-12)/2$
$Rm = MRF - R3-0^{(1)} R7-4$ (SSFR), $Ra = R11-8 + R15-12$
$Rm = MRF - R3-0^{(1)} R7-4$ (SSFR), $Ra = R11-8 - R15-12$
$Rm = MRF - R3-0^{(1)} R7-4$ (SSFR), $Ra = (R11-8 + R15-12)/2$
$Rm = R3-0^{(1)} R7-4$ (SSFR), $Ra = R11-8 + R15-12$,
$Rs = R11-8 - R15-12$

Table 9. Multifunction Compute Operations

Floating-Point
$Fm = F3-0^{(1)} F7-4, Fa = F11-8 + F15-12$
$Fm = F3-0^{(1)} F7-4, Fa = F11-8 - F15-12$
$Fm = F3-0^{(1)} F7-4, Fa = \text{FLOAT } R11-8 \text{ by } R15-12$
$Fm = F3-0^{(1)} F7-4, Fa = \text{FIX } R11-8 \text{ by } R15-12$
$Fm = F3-0^{(1)} F7-4, Fa = (F11-8 + F15-12)/2$
$Fm = F3-0^{(1)} F7-4, Fa = \text{ABS } F11-8$
$Fm = F3-0^{(1)} F7-4, Fa = \text{MAX } (F11-8, F15-12)$
$Fm = F3-0^{(1)} F7-4, Fa = \text{MIN } (F11-8 + F15-12)$
$Fm = F3-0^{(1)} F7-4, Fa = F11-8 + F15-12,$
$Fs = F11-8 - F15-12$

Ra, Rm Any register file location (fixed-point)

R3-0 R3, R2, R1, R0

R7-4 R7, R6, R5, R4

R11-8 R11, R10, R9, R8

R15-12 R15, R14, R13, 12

Fa, Fm Any register file location (floating-point)

F3-0 F3, F2, F1, F0

F7-4 F7, F6, F5, F4

F11-8 F11, F10, F9, F8

F15-12 F15, F14, F13, F12

(SSF) X-input signed, Y-input signed, fractional inputs

(SSFR) X-input signed, Y-input signed, fractional inputs, rounded output

Table 10. Interrupt Vector Addresses and Priorities

No	Vector Address (Hex)	Function
0	0x00	Reserved
1 ⁽¹⁾	0x08	Reset
2	0x10	Reserved
3	0x18	Status stack or loop stack overflow or PC stack full
4	0x20	Timer = 0 (high priority option)
5	0x28	IRQ3 asserted
6	0x30	IRQ2 asserted
7	0x38	IRQ1 asserted
8	0x40	IRQ0 asserted
9	0x48	Reserved
10	0x50	Reserved
11	0x58	DAG 1 circular buffer 7 overflow
12	0x60	DAG 2 circular buffer 15 overflow

Table 10. Interrupt Vector Addresses and Priorities (Continued)

No	Vector Address (Hex)	Function
13	0x68	Reserved
14	0x70	Timer = 0 (low priority option)
15	0x78	Fixed-point overflow
16	0x80	Floating-point overflow
17	0x88	Floating-point underflow
18	0x90	Floating-point invalid operation
19-23	0x98-0xB8	Reserved
24-31	0xC0-0xF8	User software interrupts

Note: 1. Nonmaskable

Electrical Characteristics

Absolute Maximum Ratings

Supply Voltage.....	-0.5V to + 7V
Input Voltage.....	-0.5V to VDD + 0.5V
Output Voltage Swing	-0.5V to VDD + 0.5V
Load Capacitance.....	200 pF
Operating Temperature Range (Ambient).....	-55°C to + 125°C
Storage Temperature Range	-65°C to + 150°C

*Note: Stresses above those listed under "Absolute Maximum Ratings" may cause permanent damage to the device. These are stress ratings only and functional operation of the device at these or any other conditions above those indicated in the operational sections of this specification is not implied. Exposure to absolute maximum rating conditions for extended periods may affect device reliability.

Recommended Operating Conditions

Parameter	Mil Range		Unit
	Min	Max	
V _{DD} Supply Voltage	4.50	5.50	V
T _{AMB} Ambient Operating Temperature	-55	+125	°C

ESD Sensitivity

The TSC21020F features proprietary input protection circuitry to dissipate high-energy discharges (Human Body Model). Per method 3015 of MIL-STD-883, the TSC21020F has been classified as a Class 2 devices, with the ability to withstand up to 2000V ESD.

Proper ESD precautions are strongly recommended to avoid functional damage or performance degradation. Charges readily accumulate on the human body and test equipment and discharge without detection. Unused devices must be stored in conductive foam or shunts, and the foam should be discharged to the destination socket before devices are removed.

DC Parameters

Parameter	Test Conditions	Min	Max	Unit
V _{IH} Hi-Level Input Voltage ¹	V _{DD} = max	2.0		V
V _{IHCR} Hi-Level Input Voltage ^{2, 12}	V _{DD} = max	3.0		V
V _{IL} Lo-Level Input Voltage ^{1, 12}	V _{DD} = min		0.8	V
V _{ILC} Lo-Level Input Voltage ²	V _{DD} = min		0.6	V
V _{OH} Hi-Level Output Voltage ^{3, 11}	V _{DD} = min, I _{OH} = -1.0 mA	2.4		V
V _{OL} Lo-Level Output Voltage ^{3, 11}	V _{DD} = min, I _{OL} = 4.0 mA		0.4	V
I _{IH} Hi-Level Input Current ^{4, 5}	V _{DD} = max, V _{IN} = V _{DD} max		10	μA
I _{IL} Lo-Level Input Current ⁴	V _{DD} = max, V _{IN} = 0V		10	μA
I _{ILT} Lo-Level Input Current ⁵	V _{DD} = max, V _{IN} = 0V		350	μA
I _{OZL} Tristate Leakage Current ⁶	V _{DD} = max, V _{IN} = 0V		10	μA
I _{DDIN} Supply Current (Internal) ⁷	t _{CK} = 50 ns, V _{DD} = max, V _{IHCR} = 3.0V, V _{IH} = 2.4V, V _{IL} = V _{ILC} = 0.4V		430	mA

Parameter	Test Conditions	Min	Max	Unit
I_{DDIDLE} Supply Current (Idle) ⁸	$V_{DD} = \text{max}$, $V_{IN} = 0V$ or $V_{DD} \text{ max}$		150	mA
C_{IN} Input Capacitance ^{9, 10}	$f_{IN} = 1 \text{ MHz}$, $T_{CASE} = 255C$, $V_{IN} = 2.5V$		10	pF

- Notes:
1. Applies to: PMD47-0, PMACK, PMTS, DMD39-0, DMACK, DMTS, IRQ3-0, FLAG3-0, BR, TMS, TDI.
 2. Applies to: CLKIN, TCK.
 3. Applies to: PMA23-0, PMD47-0, PMS1-0, PMRD, PMWR, PMPAGE, DMA31-0, DMD39-0, DMS3-0, DMRD, DMWR, DMPAGE, FLAG3-0, TIMEXP, BG.
 4. Applies to: PMACK, PMTS, DMACK, DMTS, IRQ3-0, BR, CLKIN, RESET, TCK.
 5. Applies to: TMS, TDI, TRST.
 6. Applies to: PMA23-0, PMD47-0, PMS1-0, PMRD, PMWR, PMPAGE, DMA31-0, DMD39-0, DMS3-0, DMRD, DMWR, DMPAGE, FLAG3-0, TDO.
 7. Applies to IVDD pins. At $t_{CK} = 50\text{ns}$, I_{DDIN} (typical) = 350 mA. See "Power Dissipation" for calculation of external (EVDD) supply current for total supply current.
 8. Applies to IVDD pins. Idle refers to TSC21020F state of operation during execution of the IDLE instruction.
 9. Guaranteed but not tested.
 10. Applies to all signal pins.
 11. Although specified for TTL outputs, all TSC21020F outputs are CMOS-compatible and will drive to V_{DD} and GND assuming no dc loads.
 12. Applies to RESET, TRST.

AC Parameters

See Figure 15 for voltage reference levels. Use the exact timing information given. Do not attempt to derive parameters from the addition or subtraction of others. While addition or subtraction would yield meaningful results for an individual device, the values given in this data sheet reflect statistical variations and worst cases. Consequently, you cannot meaningfully add parameters to derive other specifications.

Clock Signal

Parameter	20 MHz		Unit
	Min	Max	
T _{CK} CLKIN Period	50	150	ns
t _{CKH} CLKIN Width High	10		ns
t _{CKL} CLKIN Width Low	10		ns

Figure 3. Clock

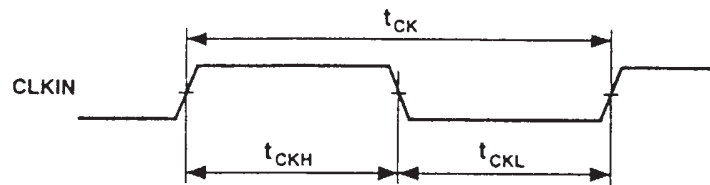

Reset

Parameter	20 MHz		Frequency Dependency ⁽¹⁾		Unit
	Min	Max	Min	Max	
t _{WRST} ⁽²⁾ RESET Width Low	200		4t _{CK}		ns
t _{SRST} ⁽³⁾ RESET Setup before CLKIN High	29	50	29 + DT/2	30	ns

- Notes:
1. DT = t_{CK} - 50 ns
 2. Applies after the power-up sequence is complete. At power up, the Internal Phase Locked Loop requires no more than 1000CLKIN cycles while RESET is low, assuming stable V_{DD} and CLKIN (not including clock oscillator start-up time).
 3. Specification only applies in cases where multiple TSC21020F processors are required to execute in program counter lock-step (all processors start execution at location 8 in the same cycle). See the Hardware Configuration chapter of the *ADSP-21020 User's Manual from Analog Devices* for reset sequence information.

Figure 4. Reset

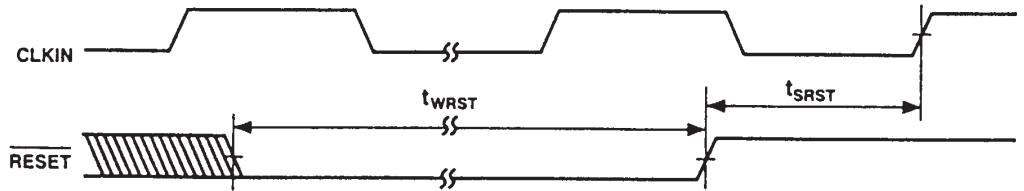

Interrupts

Parameter	20 MHz	Frequency Dependency ⁽¹⁾	Unit
	Min		
t_{SIR} $\overline{IRQ3-0}$ Setup before CLKIN High	38	$38 + 3DT/4$	ns
t_{HIR} $\overline{IRQ3-0}$ Hold after CLKIN High	0		ns
t_{IPW} $\overline{IRQ3-0}$ Pulse Width	55	$t_{CK} + 5$	ns

Note: 1. $DT = t_{CK} - 50$ ns

Meeting setup and hold guarantees interrupts will be latched in that cycle. Meeting the pulse width is not necessary if the setup and hold is met. Likewise, meeting the setup and hold is not necessary if the pulse width is met. See the Hardware Configuration chapter of the *ADSP-21020 User's Manual* from Analog Devices for interrupt servicing information.

Figure 5. Interrupts

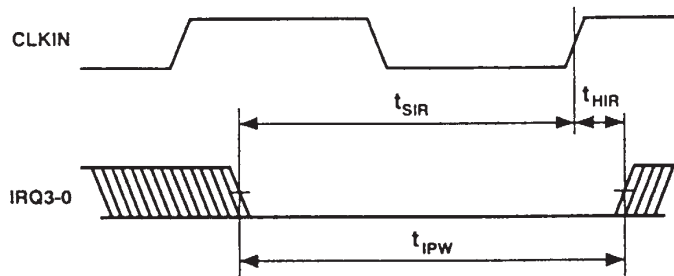

Timer

Parameter	20 MHz	Frequency Dependency ⁽¹⁾		Unit
	Max	Min	Max	
t_{DTEX} CLKIN High to TIMEXP	24			ns

Note: 1. $DT = t_{CK} - 50$ ns

Figure 6. TIMEXP

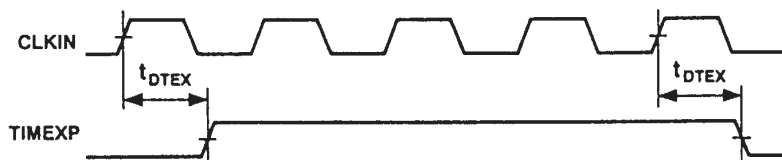

Flags

Parameter	20 MHz		Frequency Dependency ⁽¹⁾		Unit
	Min	Max	Min	Max	
$t_{SFI}^{(2)}$ FLAG3-0 _{IN} Setup before CLKIN High	19		19 + 5DT/16		ns
$t_{HFI}^{(2)}$ FLAG3-0 _{IN} Hold after CLKIN High	0			12 + 7DT/16	ns
$t_{DWRFI}^{(2)}$ FLAG3-0 _{IN} Delay from xRD, xWR Low		12			ns
$t_{HFIWR}^{(2)}$ FLAG3-0 _{IN} Hold after xRD, xWR Deasserted	0				ns
t_{DFO} FLAG3-0 _{OUT} Delay from CLKIN High		24			ns
t_{HFO} FLAG3-0 _{OUT} Hold after CLKIN High	5				ns
t_{DFOE} CLKIN High to FLAG3-0 _{OUT} Enable ⁽³⁾	1				ns
t_{DFOD} CLKIN High to FLAG3-0 _{OUT} Disable		24			ns

- Notes: 1. $DT = t_{CK} - 50$ ns
 2. Flag inputs meeting these setup and hold times will affect conditional operations in the next instruction cycle. See the Hardware Configuration chapter of the *ADSP-21020 User's Manual from Analog Devices* for additional flag servicing information.
 3. Guaranteed by design.

Figure 7. Flags

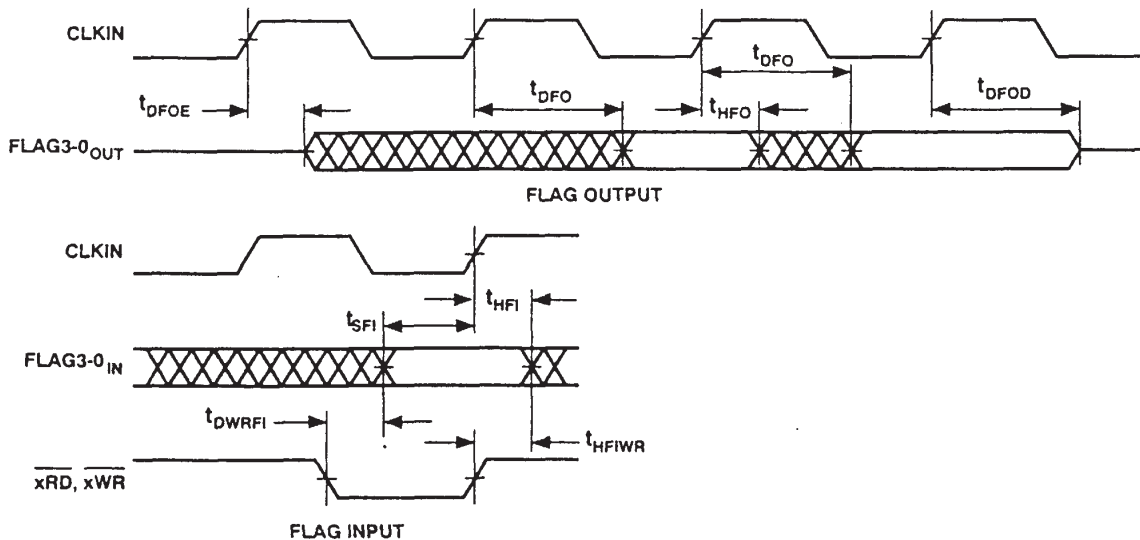

Bus Request/Bus Grant

Parameter	20 MHz		Frequency Dependency ⁽¹⁾		Unit
	Min	Max	Min	Max	
t_{HBR} \overline{BR} Hold after CLKIN High	0				ns
t_{SBR} \overline{BR} Setup before CLKIN High	18		$18+5DT/16$		ns
t_{DMDBGL} Memory Interface Disable to \overline{BG} Low ⁽²⁾	-2				ns
t_{DME} CLKIN High to Memory Interface Enable	25		$25 + DT/2$		ns
t_{DBGL} CLKIN High to \overline{BG} Low		22			ns
t_{DBGH} CLKIN High to \overline{BG} High		22			ns

Notes: 1. $DT = t_{CK} - 50$ ns

Memory Interface = PMA23-0, PMD47-0, PMS1-0, PMRD, PMWR, PMPAGE, DMA31-0, DMD39-0, DMS3-0, DMRD, DMWR, DMPAGE.

Buses are not granted until completion of current memory access.

See the Memory Interface chapter of the *ADSP-21020 User's Manual* from Analog Devices for BG, BR cycle relationships.

2. Guaranteed by design.

Figure 8. Bus Request/Bus Grant

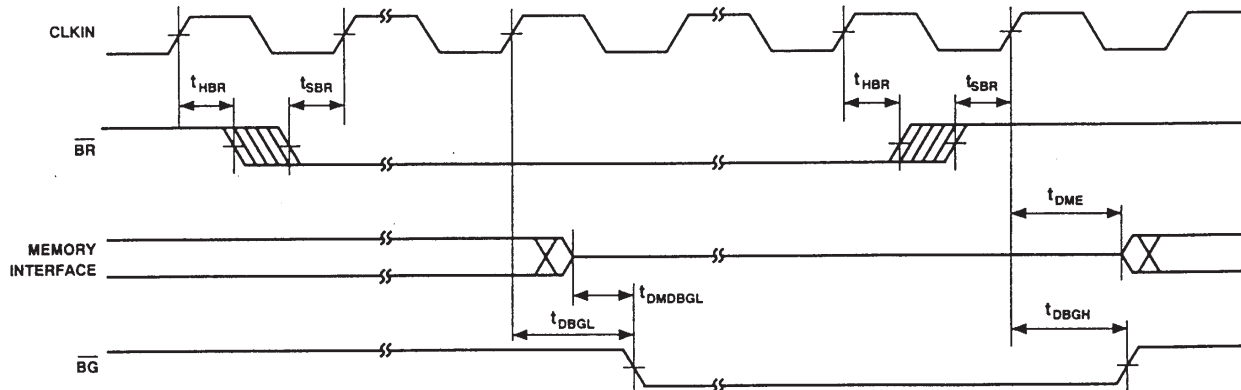

External Memory Three-State Control

Parameter	20 MHz		Frequency Dependency ⁽¹⁾		Unit
	Min	Max	Min	Max	
t_{STS} \overline{XTS} , Setup before CLKIN High	14	50	$14 + DT/4$	t_{CK}	ns
t_{DADTS} \overline{XTS} Delay after Address, Select		28		$28 + 7DT/8$	ns
t_{DSTS} \overline{XTS} , Delay after XRD, XWR Low		16		$16 + DT/2$	ns
t_{DTSD} Memory Interface Disable before CLKIN High	0		$DT/4$		ns
t_{DTSAE} \overline{XTS} High to Address, Select Enable	0				ns

Notes: 1. $DT = t_{CK} - 50$ ns
 \overline{XTS} should only be asserted (low) during an active memory access cycle.
 Memory Interface = PMA23-0, PMD47-0, PMS1-0, PMRD, PMWR, PMPAGE, DMA31-0, DMD39-0, DMS3-0, DMRD, DMWR, DMPAGE.
 Address = PMA23-0, DMA31-0, Select = PMS1-0, DMS3-0
 x = PM or DM.

Figure 9. External Memory Three-State Control

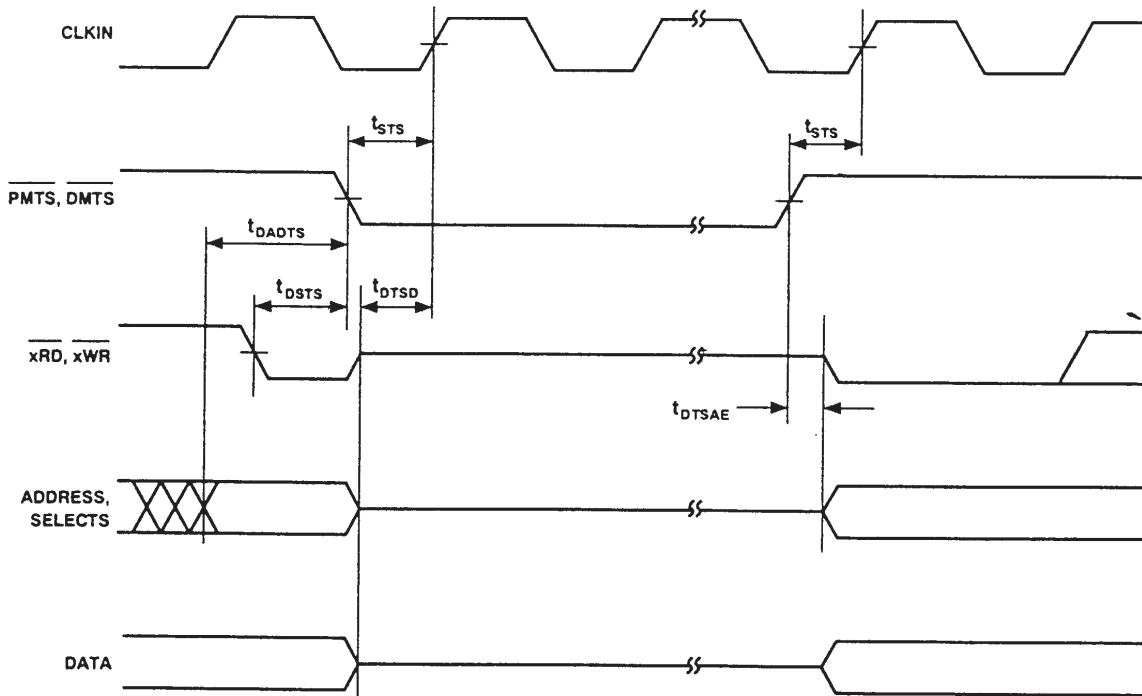

Memory Read

Parameter	20 MHz		Frequency Dependency ⁽¹⁾		Unit
	Min	Max	Min	Max	
t_{DAD} Address, Select to Data Valid		37		$37 + DT$	ns
t_{DRLD} \overline{xRD} Low to Data Valid		24		$24 + 5DT/8$	ns
t_{HDA} Data Hold from Address, Select	0				ns
t_{HDRH} Data Hold from \overline{xRD} High	-1				ns
t_{DAAK} $xACK$ Delay from Address		27		$27 + 7DT/8$	ns
t_{DRAK} $xACK$ Delay from \overline{xRD} Low		15		$15 + DT/2$	ns
t_{SAK} $xACK$ Setup before CLKIN High	14		$14 + DT/4$		ns
t_{HAK} $xACK$ Hold after CLKIN High	0				ns
t_{DARL} Address, Select to \overline{xRD} Low	8		$8 + 3DT/8$		ns
t_{DAP} $xPAGE$ Delay from Address, Select		1			ns
t_{DCKRL} CLKIN High to \overline{xRD} Low	16	26	$16 + DT/4$	$26 + DT/4$	ns
t_{RW} \overline{xRD} Pulse Width	26		$26 + 5DT/8$		ns
t_{RWR} \overline{xRD} High to \overline{xRD} , \overline{xWR} Low	17		$17 + 3DT/8$		ns

- Notes: 1. $DT = t_{CK} - 50$ ns
 2. $x = PM$ or DM ; Address = PMA23-0, DMA31-0; Data = PMD47-0, DMD39-0; Select = PMS1-0, DMS3-0.

Figure 10. Memory Read

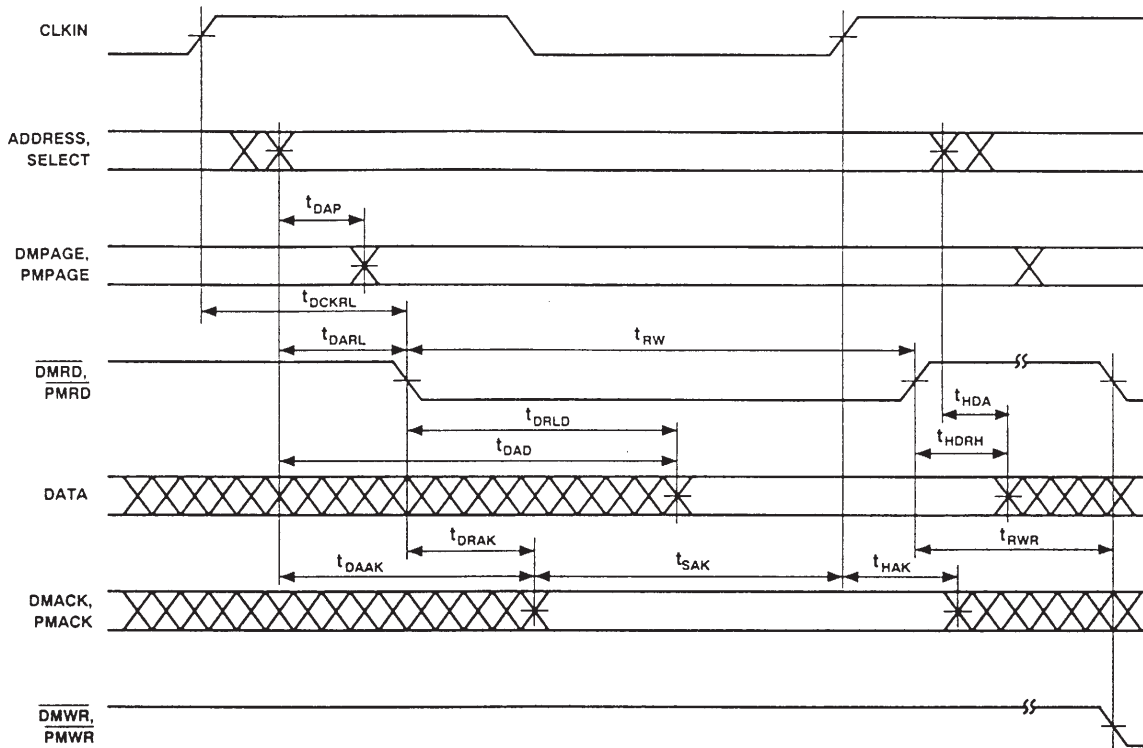

Memory Write

Parameter	20 MHz		Frequency Dependency ⁽¹⁾		Unit
	Min	Max	Min	Max	
t_{DAAK} xACK Delay from Address, Select		27		$27 + 7DT/8$	ns
t_{DWAk} xACK Delay from \overline{xWR} Low		15		$15 + DT/2$	ns
t_{SAK} xACK Setup before CLKIN High	14		$14 + DT/4$		ns
t_{HAK} xACK Hold after CLKIN High	0				ns
t_{DAWH} Address, Select to \overline{xWR} Deasserted	37		$37 + 15DT/16$		ns
t_{DAWL} Address, Select to \overline{xWR} Low	11		$11 + 3DT/8$		ns
t_{WW} \overline{xWR} Pulse Width	26		$26 + 9DT/16$		ns
t_{DDWH} Data Setup before \overline{xWR} High	23		$23 + DT/2$		ns

Parameter	20 MHz		Frequency Dependency ⁽¹⁾		Unit
	Min	Max	Min	Max	
t_{DWHA} Address, Select Hold after \overline{xWR} Deasserted ⁽²⁾	1		$1 + DT/16$		ns
t_{HDWH} Data Hold after \overline{xWR} Deasserted ⁽²⁾	0		$DT/16$		ns
t_{DAP} \overline{xPAGE} Delay from Address, Select		1			ns
t_{DCKWL} CLKIN High to \overline{xWR} Low	16	26	$16 + DT/4$	$26 + DT/4$	ns
t_{WWR} \overline{xWR} High to \overline{xWR} or \overline{xRD} Low	17		$17 + 7DT/16$		ns
t_{DDWR} Data Disable before \overline{xWR} or \overline{xRD} Low	13		$13 + 3DT/8$		ns
t_{WDE} \overline{xWR} Low to Data Enabled	0		$DT/16$		ns

Notes: 1. $DT = t_C - 50$ ns

2. See "System Hold Time Calculation" in "Test Conditions" section for calculating hold times given capacitive and DC loads.

x = PM or DM; Address = PMA23-0, DMA31-0; Data = PMD47-0, DMD39-0; Select = PMS1-0, DMS3-0; guaranteed by design.

Figure 11. Memory Write

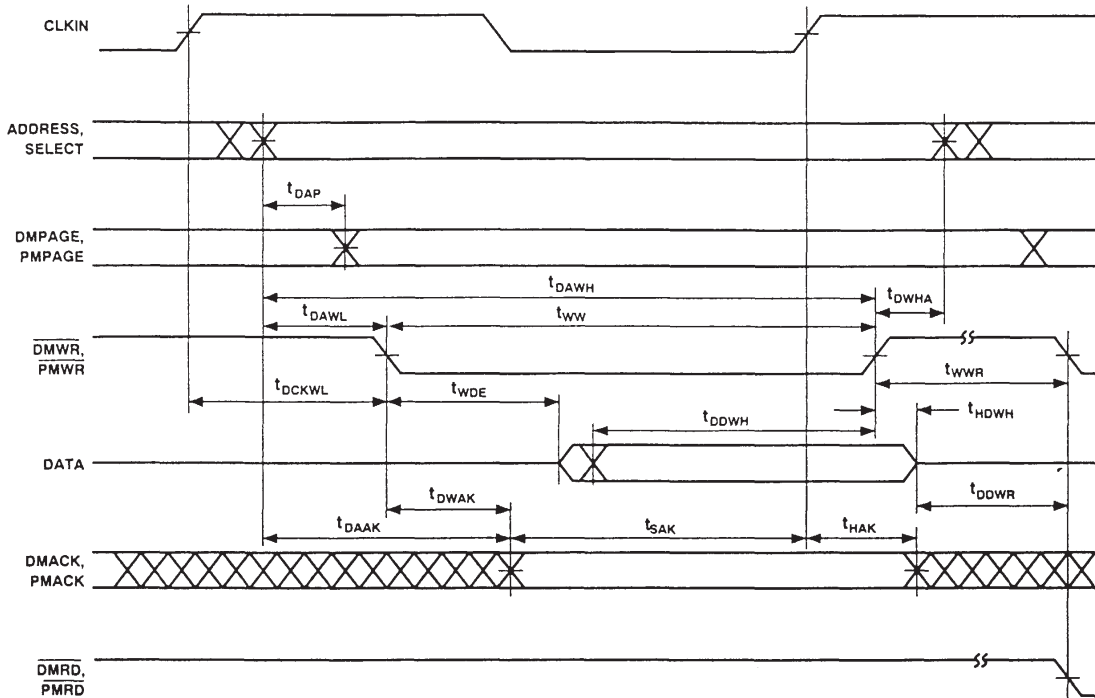

IEEE 1149.1 Test Access Port

Parameter	20 MHz		Frequency Dependency ⁽¹⁾		Unit
	Min	Max	Min	Max	
t_{TCK} TCK Period	50		t_{CK}		ns
t_{STAP} TDI, TMS Setup before TCK High	5				ns
t_{HTAP} TDI, TMS Hold after TCK High	6				ns
t_{SSYS} System Inputs Setup before TCK High	7				ns
t_{HSYS} System Inputs Hold after TCK High	9				ns
t_{TRSTW} \overline{TRST} Pulse Width	200				ns
t_{DTDO} TDO Delay from TCK Low		15			ns
t_{DSYS} System Outputs Delay from TCK Low		26			ns

Note: 1. $DT = t_{CK} - 50$ ns

System Inputs = $\overline{PMD47-0}$, \overline{PMACK} , \overline{PMTS} , $\overline{DMD39-0}$, \overline{DMACK} , \overline{DMTS} , \overline{CLKIN} , $\overline{IRQ3-0}$, \overline{RESET} , $\overline{FLAG3-0}$, \overline{BR} .

System Outputs = $\overline{PMA23-0}$, $\overline{PMS1-0}$, \overline{PMRD} , \overline{PMWR} , $\overline{PMD47-0}$, \overline{PMPAGE} , $\overline{DMA31-0}$, $\overline{DMS3-0}$, \overline{DMRD} , \overline{DMWR} , \overline{DMPAGE} , $\overline{FLAG3-0}$, \overline{BG} , \overline{TIMEXP} .

See the IEEE 1149.1 Test Access Port chapter of the *ADSP-21020 User's Manual* from Analog Devices for further detail.

Figure 12. IEEE 1149.1 Test Access Port

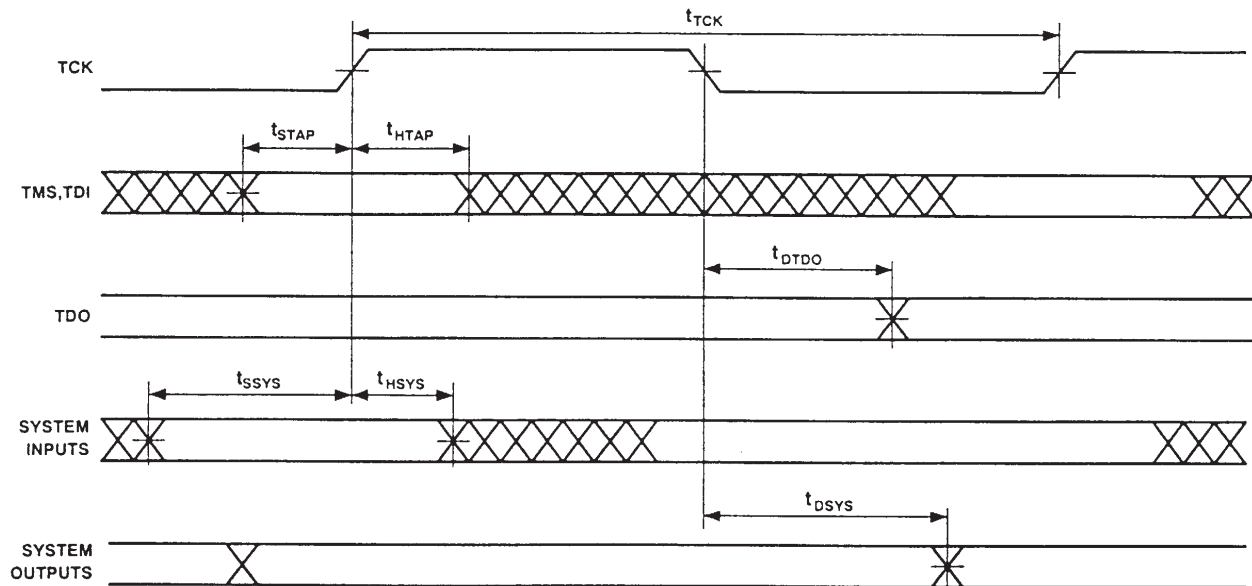
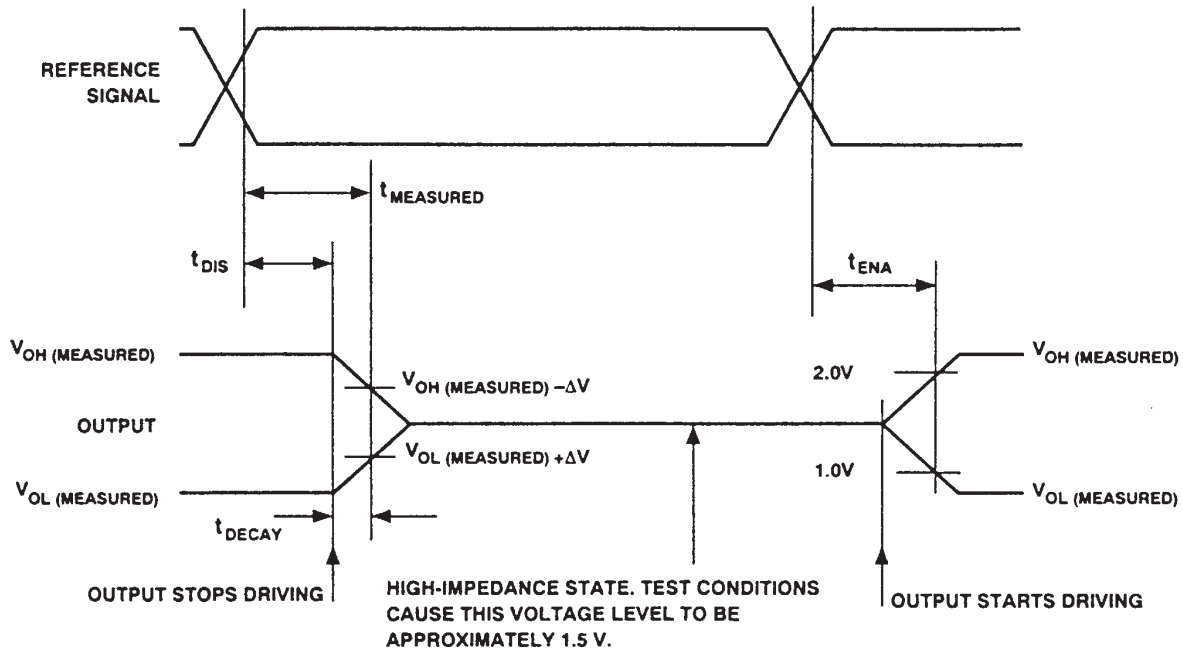

Figure 13. Output Enable/Disable



Test Conditions

Output Disable Time

Output pins are considered to be disable when they stop driving, go into a high-impedance state, and start to decay from their output high or low voltage. The time for the voltage on the bus to decay by ΔV is dependent on the capacitive load, C_L , and the load current, I_L . It can be approximated by the following equation:

$$t_{DECAY} = \frac{C_L \Delta V}{I_L}$$

The output disable time (t_{DIS}) is the difference between $t_{MEASURED}$ and t_{DECAY} as shown in Figure 13. The time $t_{MEASURED}$ is the interval from when the reference signal switches to when the output voltage decays ΔV from the measured output high or output low voltage. t_{DECAY} is calculated with ΔV equal to 0.5V, and test loads C_L and I_L .

Output Enable Time

Output pins are considered to be enabled when they have made a transition from a high-impedance state to when they start driving. The output enable time (t_{ENA}) is the interval from when a reference signal reaches a high or low voltage level to when the output has reached a specified high or low trip point, as shown in the Output Enable/Disable diagram. If multiple pins (such as the data bus) are enabled, the measurement value is that of the first pin to start driving.

Figure 14. Equivalent Device Loading for AC Measurements (Includes all Fixtures)

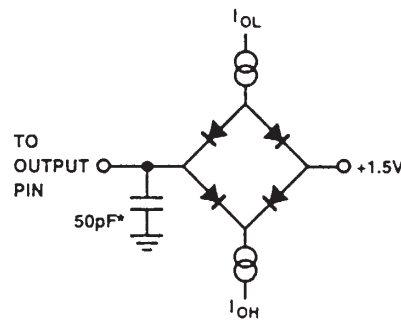

*AC TIMING SPECIFICATIONS ARE CALCULATED FOR 100pF DERATING ON THE FOLLOWING PINS: PMA23-0, PMS1-0, PMRD, PMWR, PMPAGE, DMA31-0, DMS3-0, DMRD, DMWR, DMPAGE

Example System Hold Time Calculation

To determine the data output hold time in a particular system, first calculate t_{DECAY} using the above equation. Choose ΔV to be the difference between the TSC21020F's output voltage and the input threshold for the device requiring the hold time. A typical ΔV will be 0.4V. C_L is the total bus capacitance (per data line), and I_L is the total leakage or three-state current (per data line). The hold time will be t_{DECAY} plus the minimum disable time (i.e. t_{HDWD} for the write cycle).

Figure 15. Voltage Reference Levels for AC Measurements (Except Output Enable/Disable)



Capacitive Loading

Output delays are based on standard capacitive loads: 100 pF on address, select, page and strobe pins, and 50 pF on all others (see Figure 14). For different loads, these timing parameters should be derated. See the Hardware Configuration chapter of the ADSP-21020 User's Manual from Analog Devices for further information on derating of timing specifications.

Figures 16 and 17 show how the output rise time varies with capacitance. Figures 18 and 19 show how output delays vary with capacitance. Note that the graphs may not be linear outside the ranges shown.

Figure 16. Typical Output Rise Time vs. Load Capacitance (at Maximum Case Temperature)

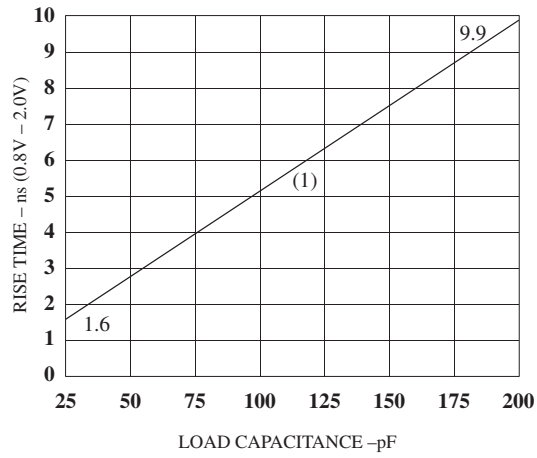

Note:
 (1) OUTPUT PINS \overline{BG} , TIMEXP, PMD47-0, DMD39-0, FLAG3-0

Figure 17. Typical Output Rise Time vs. Load Capacitance (at Maximum Case Temperature)

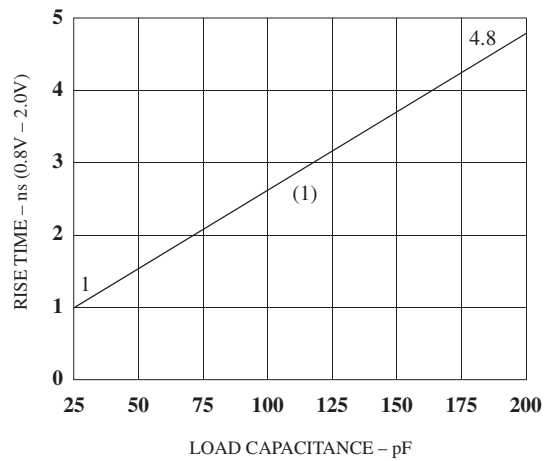

Note:
 (1) OUTPUT PINS PMA23-0, \overline{PMSTI} -0, PMPAGE, DMA31-0, DMS3-0, DMPAGE, TDO, PMRD, PMWR, DMRD, DMWR

Figure 18. Typical Output Delay or Hold vs. Load Capacitance (at Maximum Case Temperature)

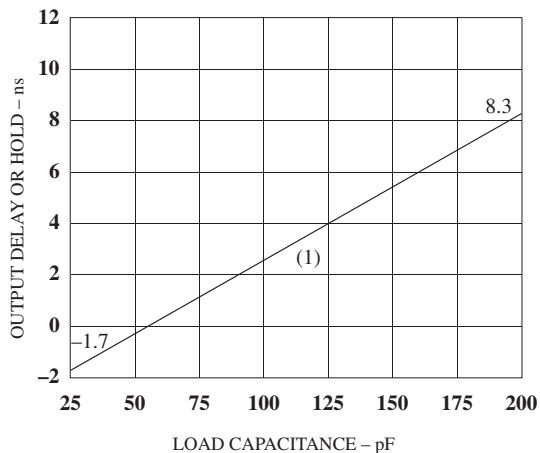

Note:
 (1) OUTPUT PINS \overline{BG} , \overline{TIMEXP} , FLAG3-0,
 PMD47-0, DMD39-0

Figure 19. Typical Output Delay or Hold vs. Load Capacitance (at Maximum Case Temperature)

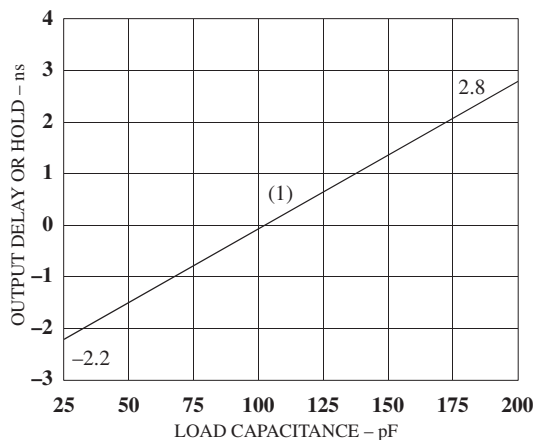

Note:
 (1) OUTPUT PINS PMA-23, $\overline{PMS1-0}$, PMPAGE, DMA31-0,
 $\overline{DMS3-0}$, DMPAGE, TDO, \overline{PMRD} , \overline{PMWR} , \overline{DMRD} , \overline{DMWR}

Power Dissipation

Total power dissipation has two components: one due to internal circuitry and one due to the switching of external output drivers.

Internal power dissipation is dependent on the instruction execution sequence and the data values involved. Internal power dissipation is calculated in the following way:

$$P_{INT} = I_{DDIN} \times V_{DD}$$

The external component of total power dissipation is caused by the switching of output pins. Its magnitude depends on:

- 1) the number of output pins that switch during each cycle(O),
- 2) the maximum frequency at which they can switch (f),
- 3) their load capacitance (C), and

4) their voltage swing (V_{DD}).

It is calculated by:

$$P_{EXT} = O \times C \times V_{DD}^2 \times f$$

The load capacitance should include the processor's package capacitance (C_{IN}). The switching frequency includes driving the load high and then back low. Address and data pins can drive high and low at a maximum rate of $1/(2t_{CK})$. The write strobes can switch every cycle at a frequency of $1/t_{CK}$. Select pins switch at $1/(2t_{CK})$, but 2 DM and 2 PM selects can switch on each cycle. If only one bank is accessed, no select line will switch.

For instance, the maximum power dissipation will be:

$$P_{INT\ Max} = I_{DDIN\ Max} \times V_{DD\ Max} = 0,430 \times 5,5 = 2,36W$$

$$P_{EXT\ Max} = O \times C \times V_{DD\ Max}^2 \times f$$

$$= 164 \times 10^{-11} \times 5.5^2 \times 20.10^6 = 0.99W$$

$$P_{max} = 3.4W$$

Power and Ground Guidelines

Pin Type	# Pins	% Switch	xC	xf	xV _{DD} ²	P _{EXT}
PMA	15	50	68 pF	5 MHz	25V	0.064W
\overline{PMS}	2	0	68 pF	5 MHz	25V	0.000W
\overline{PMWR}	1	-	68 pF	10 MHz	25V	0.017W
PMD	32	50	18 pF	5 MHz	25V	0.036W
DMA	15	50	48 pF	5 MHz	25V	0.045W
\overline{DMS}	2	0	48 pF	5 MHz	25V	0.000W
\overline{DMWR}	1	-	48 pF	10 MHz	25V	0.012W
DMD	32	50	18 pF	5 MHz	25V	0.036W

$$P_{EXT} = 0.210W$$

To achieve its fast cycle time, including instruction fetch, data access, and execution, the TSC21020F is designed with high speed drivers on all output pins. Large peak currents may pass through a circuit board's ground and power lines, especially when many output drivers are simultaneously charging or discharging their load capacitances. These transient currents can cause disturbances on the power and ground lines. To minimize these effects, the TSC21020F provides separate supply pins for its internal logic (IGND and IVDD) and for its external drivers (EGND and EVDD).

All GND pins should have a low impedance path to ground. A ground plane is required in TSC21020F systems to reduce this impedance, minimizing noise.

The EVDD and IVDD pins should be bypassed to the ground plane using approximately 14 high-frequency capacitors (0.1 μ F ceramic). Keep each capacitor's lead and trace length to the pins as short as possible. This low inductive path provides the TSC21020F with the peak currents required when its output drivers switch. The capacitors' ground leads should also be short and connect directly to the ground plane. This provides a low impedance return path for the load capacitance of the TSC21020F's output drivers.

If a V_{DD} plane is not used, the following recommendations apply. Traces from the +5V supply to the 10 EVDD pins should be designed to satisfy the minimum V_{DD} specification while carrying average dc currents of $[I_{DDEX}/10 \times (\text{number of EVDD pins per trace})]$. I_{DDEX} is the calculated external supply current. A similar calculation should be made for the four IVDD pins using the I_{DDIN} specification. The traces connecting +5V to the IVDD pins should be separate from those connecting to the EVDD pins.

A low frequency bypass capacitor (20 μ F tantalum) located near the junction of the IVDD and EVDD traces is also recommended.

Target System Requirements for Use of EZ-ICE Emulator

The ADSP-21020 EZ-ICE uses the IEEE 1149.1 JTAG test access port of the TSC21020F to monitor and control the target board processor during emulation. The EZ-ICE probe requires that CLKIN, TMS, TCK, TRST, TDI, TDO, and GND be made accessible on the target system via a 12-pin connector (pin strip header) such as that shown in Figure 20. The EZ-ICE probe plugs directly onto this connector for chip-on-board emulation; you must add this connector to your target board design if you intend to use the ADSP-21020 EZ-ICE. Figure 21 shows the dimensions of the EZ-ICE probe; be sure to allow enough space in your system to fit the probe onto the 12-pin connector.

Figure 20. Target Board Connector for EZ-ICE Emulator (Jumpers In Place)

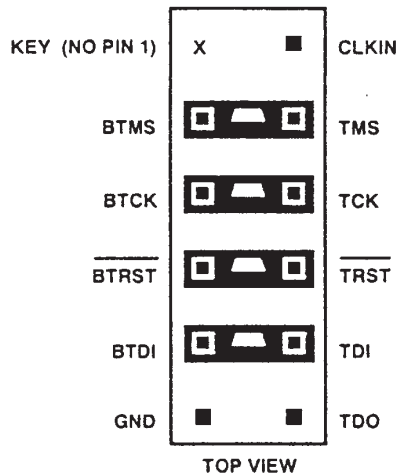
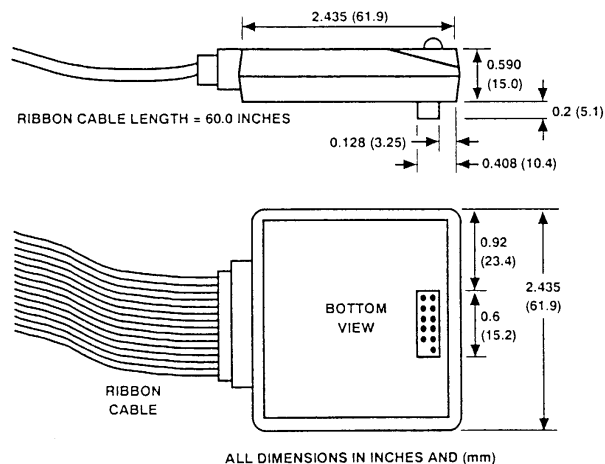

Figure 21. EZ-ICE Probe



The 12-pin, 2-row pin strip header is keyed at the Pin 1 location - you must clip Pin 1 off of the header. The pins must be 0.025 inch square and at least 0.20 inch in length. Pin spacing is 0.1 x 0.1 inches.



The tip of the pins must be at least 0.10 inch higher than the tallest component under the probe to allow clearance for the bottom of the probe. Pin strip headers are available from vendors such as 3M, McKenzie, and Samtec.

The length of the traces between the EZ-ICE probe connector and the TSC21020F test access port pins should be less than 1 inch. Note that the EZ-ICE probe adds two TTL loads to the CLKIN pin of the TSC21020F.

The BMTS, BTCK, BTRST, and BTDI signals are provided so that the test access port can also be used for board-level testing. When the connector is not being used for emulation, place jumpers between the BXXX pins and the XXX pins as shown in Figure 20. If you are not going to use the test access port for board test, tie BTRST to GND and tie or pull up BTCK to VDD. The TRST pin must be asserted (pulsed low) after power up (through BTRST on the connector) or held low for proper operation of the TSC21020F.

Ordering Information

Part Number	Temperature Range	Speed	Package	Quality Flow
TSC21020F-20MA-E	25°C	20 MHz	PGA223	Engineering Samples
TSC21020F-20MB-E	25°C	20 MHz	MQFP-F256	Engineering Samples
5962-9953901QXC	-55 to +125°C	20 MHz	MQFP-F256	QML-Q
5962-9953901VXC	-55 to +125°C	20 MHz	MQFP-F256	QML-V
951200201	-55 to +125°C	20 MHz	MQFP-F256	ESCC
TSC21020F-20MC-E	25°C	20 MHz	DIE	Engineering Samples
TSC21020F-20MC-SV	-55 to +125°C	20 MHz	DIE	QML-V

Package Drawings

223-pin Ceramic Pin Grid Array

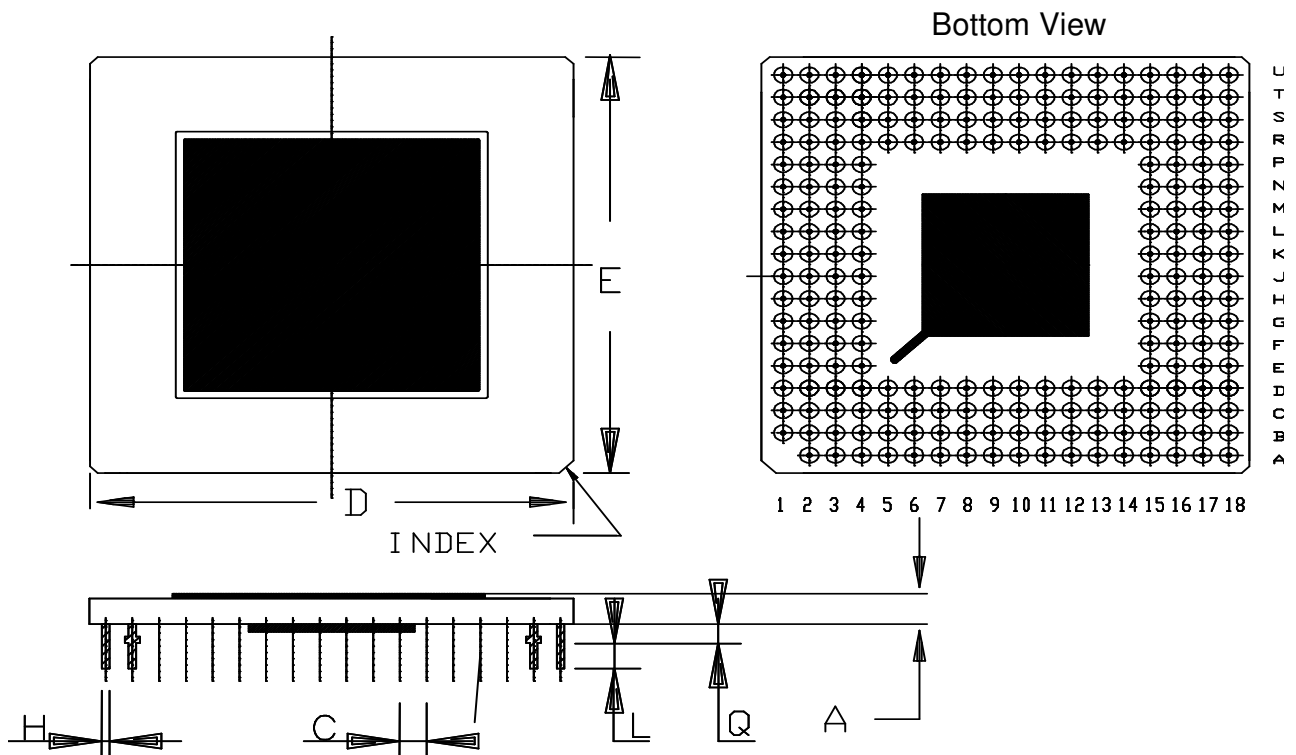

Symbol	MM		Inches	
	Min.	Max	Min.	Max
A	2.54	3.30	.100	.130

C	2.54 BSC		.100 BSC	
D	46.74	47.75	1.840	1.880
E	46.74	47.75	1.840	1.880
H	0.41	0.51	0.16	0.20
L	3.05	3.56	.120	.140
Q	1.14	1.40	0.45	.055

256-pin MQFP-F Package Top View

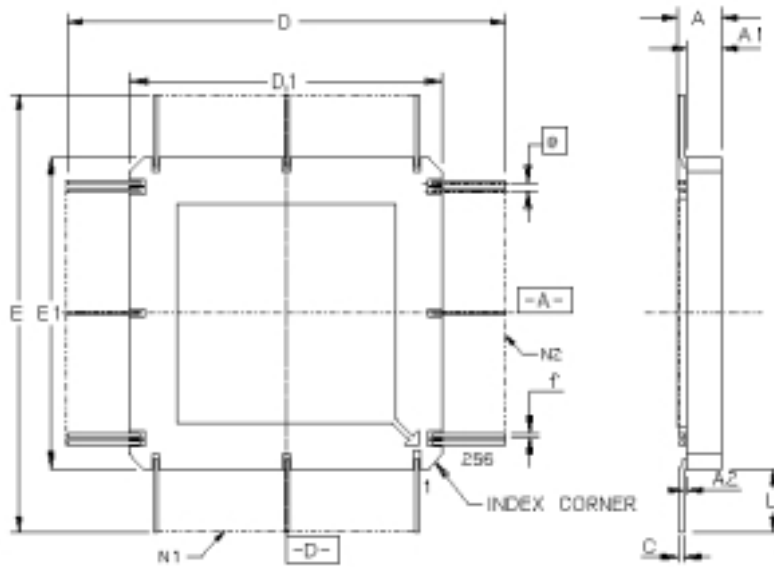

Symbol	Mils		MM	
	Min.	Max	Min.	Max
A	0.095	0.125	2.41	3.18
C	0.004	0.008	0.10	0.20
D	2.095	2.195	53.23	55.74
D ₁	1.450	1.470	36.83	37.34
E	2.095	2.195	53.23	55.74
E ₁	1.450	1.470	36.83	37.34
e	0.020 BSC		0.508 BSC	
f	0.006	0.010	0.15	0.25
A ₁	0.081	0.101	2.06	2.56
A ₂	0.002	0.014	0.05	0.36
L	0.323	0.362	8.20	9.20
N ₁	64		64	

N ₂	64	64
----------------	----	----



Atmel Headquarters

Corporate Headquarters

2325 Orchard Parkway
San Jose, CA 95131
TEL 1(408) 441-0311
FAX 1(408) 487-2600

Europe

Atmel Sarl
Route des Arsenaux 41
Case Postale 80
CH-1705 Fribourg
Switzerland
TEL (41) 26-426-5555
FAX (41) 26-426-5500

Asia

Room 1219
Chinachem Golden Plaza
77 Mody Road Tsimhatsui
East Kowloon
Hong Kong
TEL (852) 2721-9778
FAX (852) 2722-1369

Japan

9F, Tonetsu Shinkawa Bldg.
1-24-8 Shinkawa
Chuo-ku, Tokyo 104-0033
Japan
TEL (81) 3-3523-3551
FAX (81) 3-3523-7581

Atmel Operations

Memory

2325 Orchard Parkway
San Jose, CA 95131
TEL 1(408) 441-0311
FAX 1(408) 436-4314

Microcontrollers

2325 Orchard Parkway
San Jose, CA 95131
TEL 1(408) 441-0311
FAX 1(408) 436-4314

La Chantrerie
BP 70602
44306 Nantes Cedex 3, France
TEL (33) 2-40-18-18-18
FAX (33) 2-40-18-19-60

ASIC/ASSP/Smart Cards

Zone Industrielle
13106 Rousset Cedex, France
TEL (33) 4-42-53-60-00
FAX (33) 4-42-53-60-01

1150 East Cheyenne Mtn. Blvd.
Colorado Springs, CO 80906
TEL 1(719) 576-3300
FAX 1(719) 540-1759

Scottish Enterprise Technology Park
Maxwell Building
East Kilbride G75 0QR, Scotland
TEL (44) 1355-803-000
FAX (44) 1355-242-743

RF/Automotive

Theresienstrasse 2
Postfach 3535
74025 Heilbronn, Germany
TEL (49) 71-31-67-0
FAX (49) 71-31-67-2340

1150 East Cheyenne Mtn. Blvd.
Colorado Springs, CO 80906
TEL 1(719) 576-3300
FAX 1(719) 540-1759

Biometrics/Imaging/Hi-Rel MPU/ High Speed Converters/RF Data- com

Avenue de Rochepleine
BP 123
38521 Saint-Egreve Cedex, France
TEL (33) 4-76-58-30-00
FAX (33) 4-76-58-34-80

e-mail

literature@atmel.com

Web Site

<http://www.atmel.com>

Disclaimer: The information in this document is provided in connection with Atmel products. No license, express or implied, by estoppel or otherwise, to any intellectual property right is granted by this document or in connection with the sale of Atmel products. **EXCEPT AS SET FORTH IN ATMEL'S TERMS AND CONDITIONS OF SALE LOCATED ON ATMEL'S WEB SITE, ATMEL ASSUMES NO LIABILITY WHATSOEVER AND DISCLAIMS ANY EXPRESS, IMPLIED OR STATUTORY WARRANTY RELATING TO ITS PRODUCTS INCLUDING, BUT NOT LIMITED TO, THE IMPLIED WARRANTY OF MERCHANTABILITY, FITNESS FOR A PARTICULAR PURPOSE, OR NON-INFRINGEMENT. IN NO EVENT SHALL ATMEL BE LIABLE FOR ANY DIRECT, INDIRECT, CONSEQUENTIAL, PUNITIVE, SPECIAL OR INCIDENTAL DAMAGES (INCLUDING, WITHOUT LIMITATION, DAMAGES FOR LOSS OF PROFITS, BUSINESS INTERRUPTION, OR LOSS OF INFORMATION) ARISING OUT OF THE USE OR INABILITY TO USE THIS DOCUMENT, EVEN IF ATMEL HAS BEEN ADVISED OF THE POSSIBILITY OF SUCH DAMAGES.** Atmel makes no representations or warranties with respect to the accuracy or completeness of the contents of this document and reserves the right to make changes to specifications and product descriptions at any time without notice. Atmel does not make any commitment to update the information contained herein. Unless specifically provided otherwise, Atmel products are not suitable for, and shall not be used in, automotive applications. Atmel's products are not intended, authorized, or warranted for use as components in applications intended to support or sustain life.

©2007 Atmel Corporation. All rights reserved. Atmel®, logo and combinations thereof, and Everywhere You Are® are the trademarks or registered trademarks, of Atmel Corporation or its subsidiaries. Other terms and product names may be trademarks of others.



Printed on recycled paper.