

Power PCB Relay OMIT

- 1 pole, 10A, 1 form A (NO)
- UL TV-5 ating available
- Meet 5000V dielectric voltage between coil and contacts
- Meet 10000V surge voltage between coil and contacts

Typical applications
TV, home appliances



Approvals

VDE 40005414, UL E58304, CSA LR48471, SEMKO 903202, CQC 08001024660

Technical data of approved types on request

Contact Data

Contact arrangement	1 form A (NO)
Rated voltage	240VAC
Max. switching voltage	30VDC, 240VAC
Rated current	10A
Switching power	2000VA, 300W
Contact material	AgSnO
Min. recommended contact load	100mA, 5VDC
Initial contact resistance	100mOhm at 1A, 6VDC
Frequency of operation, with/without load	1800/18000h ⁻¹
Operate/release time max.	
standard coil (D)	15ms/8ms
sensitive coil (L)	20ms/8ms
Electrical endurance	
5A, 240VAC, resistive,	100x10 ³ ops.
Contact ratings	10A, 240VAC/30VDC, TV-8,
Mechanical endurance	10x10 ⁶ operations

Coil Data

Coil voltage range	5 to 48VDC
Coil insulation system according UL	class 105 (A)

Coil data (continued)

Coil versions, DC coil

Coil code	Rated voltage VDC	Operate voltage VDC	Release voltage VDC	Coil resistance Ω±10%	Rated coil power mW
Standard coil, 720mW					
05	5	3.5	0.25	36	720
06	6	4.2	0.3	48.5	720
09	9	6.3	0.45	115	720
12	12	8.4	0.6	200	720
24	24	16.8	1.2	820	720
48	48	33.6	2.4	3300	720
Sensitive coil, 540mW					
05	5	3.75	0.25	48.5	540
06	6	4.5	0.3	68	540
09	9	6.75	0.45	155	540
12	12	9.0	0.6	270	540
24	24	18.0	1.2	1100	540
48	48	36.0	2.4	4400	540

All figures are given for coil without pre-energization, at ambient temperature +23°C

Insulation Data

Initial dielectric strength	
between open contacts	1000V _{rms}
between contact and coil	5000V _{rms}
Initial surge withstand voltage	
between contact and coil	10000V
Initial insulation resistance	1000MΩ
Clearance/creepage	
between contact and coil	≥ 5.5/8mm

Electrical endurance

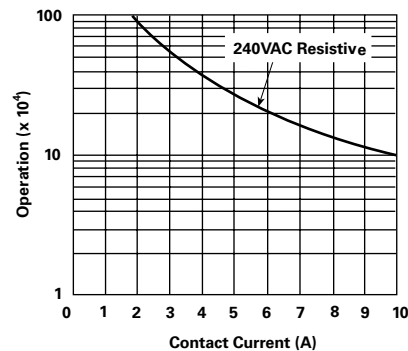

Operate time

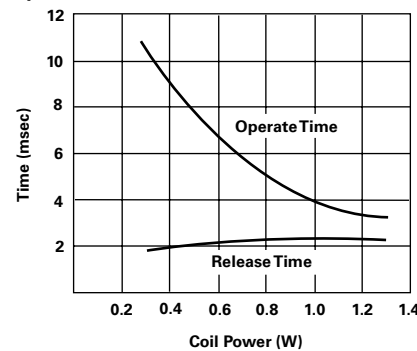

Coil temperature rise

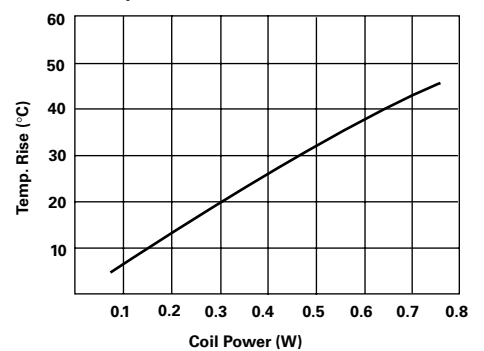

Power PCB Relay OMIT (Continued)

Other Data

Material compliance: EU RoHS/ELV, China RoHS, REACH, Halogen content refer to the Product Compliance Support Center at www.tycoelectronics.com/customersupport/rohssupportcenter

Ambient temperature	
standard coil	-30 to 60°C
sensitive coil	-30 to 70°C
Category of environmental protection	
IEC 61810	RTII - flux proof, RTIII - wash tight
Vibration resistance (functional)	10 to 50Hz, 1.5mm double amplitude
Shock resistance (functional)	
IEC 60068-2-27 (half sine)	98m/s ² , 11ms
Terminal type	PCB-THT
Weight	13g
Resistance to soldering heat THT	
IEC 60068-2-20	260°C/5s
Packaging/unit	box/1000 pcs.

Dimensions

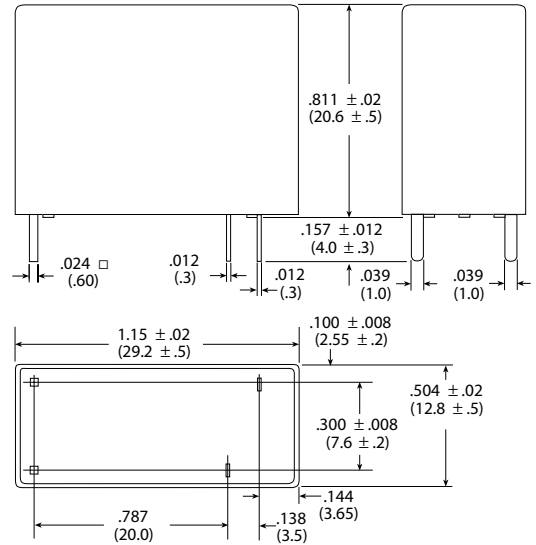

Terminal assignment

Bottom view on solder pins



PCB layout

Bottom view on solder pins

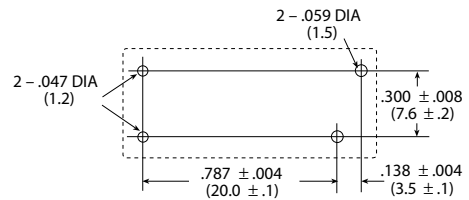

Product code structure

Typical product code **OMIT SS 1 12 D M ,300**

Type	OMIT Power PCB Relay OMIT
Sealing	SS Flux proof SH Wash tight
Pole	1 1 pole
Coil	coil Coil code: please refer to coil versions table
Coil power	D Standard 720mW L Sensitive 540mW
Contact arrangement	Blank 1 form C (CO) M 1 form A (NO)
Suffix	,300 Flux proof ,394 Wash tight

Product code	Version	Contact	Cont.material	Coil power	Coil voltage	Sealing	Part number
OMIT-SS-105DM,300	10A	1 form A (NO)	AgSnO	720mW	5VDC	Flux proof	1461208-3
OMIT-SS-112DM,300					12VDC		1-1461208-2
OMIT-SS-124DM,300					24VDC		1440001-5
OMIT-SS-105LM,300				540mW	5VDC		1440001
OMIT-SS-112LM,300					12VDC		1440001-4
OMIT-SS-124LM,300					24VDC		1440001-6
OMIT-SH-105DM,394				720mW	5VDC	Wash tight	1461387-2
OMIT-SH-112DM,394					12VDC		1-1461387-4
OMIT-SH-124DM,394					24VDC		1-1461387-7
OMIT-SH-105LM,394				540mW	5VDC		1461387-4
OMIT-SH-112LM,394					12VDC		9-1440000-6
OMIT-SH-124LM,394					24VDC		1-1461387-9