

Technical Specification

HB75-48 Series

48Vin 2.5, 3.3, 5.0, 12, 15, 24Vout 75W

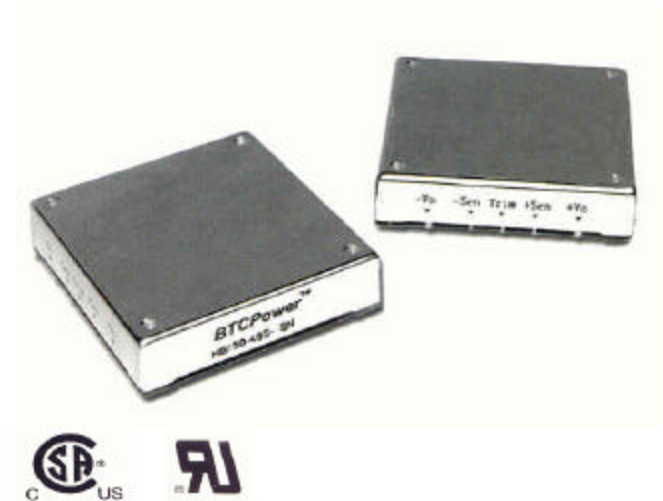

Description

The HB75 Series of low cost half brick DC/DC converters are comparable to existing half-bricks. They are targeted specifically at the telecommunication, industrial electronics, mobile telecommunication and distributed power markets. With a wide input voltage range of 36-75V they are available with output voltage of either 2.5, 3.3, 5, 12, 15 or 24Volts. All models feature an input filter, input undervoltage lockout, output overvoltage and overtemperature protection, output current limiting and short circuit protection. The unique open-frame construction with aluminum heat spreader design achieves efficient heat transfer with no hot spots.

Applications

- Telecommunications
- Data Communications
- Wireless Communications
- Networking Gear
- Servers, Switches and Data Storage
- Semiconductor Test Equipment
- Distributed Power Architecture

Features

- Delivers up to 75W in half brick
- No minimum load required
- Low profile of only 0.50 inch
- 2.5V, 3.3V, 5V, 12V, 15V or 24V output models
- Wide input operating range 36-75V
- -40°C to +100°C ambient operation
- On/Off pin and remote sense
- Output adjustment +10% and -10% range
- 1500V, 10M input-to-output isolation
- Meets Basic Insulation requirements of EN60950
- UL 1950 recognized, TUV EN60950 and CSA C22.2 No. 60950-00 Certified (pending)
- Meets conducted limits of FCC Class B and CEI IEC61204-3 Class B with external filter
- MTBF of 1,000,000 hours @ 50°C (Bellcore)

CONVERTER SELECTION

Typical @ T_a=+25°C under nominal line voltage and 75% load conditions, unless noted.

Model		Input				Output		Efficiency
Part Number		Voltage (Volts)		Current (A)		Voltage	Current	75% Load
Positive Logic	Negative Logic	Nominal	Range	No load	Full load	(Volts)	(Amps)	(%)
HB75-48-25	HB75-48-25N	48	36-75	0.1	1.05	2.5	15	77
HB75-48-33	HB75-48-33N	48	36-75	0.1	1.31	3.3	15	79
HB75-48-05	HB75-48-05N	48	36-75	0.1	1.88	5.0	15	83
HB75-48-12	HB75-48-12N	48	36-75	0.1	1.83	12	6.25	85
HB75-48-15	HB75-48-15N	48	36-75	0.1	1.84	15	5.0	85
HB75-48-24	HB75-48-24N	48	36-75	0.1	1.82	24	3.13	85

Consult factory for other output voltage configurations.

Outline and Pin-out Information

Pin Connection	
Pin#	Function
1	Vin +
2	On/Off
3	Case
4	Vin -
5	Vout -
6	Sense -
7	Trim
8	Sense +
9	Vout +

All dimensions are in inches [mm]

Pin 5 and 9 are dia. 0.08 [2.03]

All other pins are all dia. 0.040 [1.02]

Pin material: Brass

Pin finish: Tin/Lead plated

Heat spreader (baseplate) material: Aluminum

Weight: 60.5g

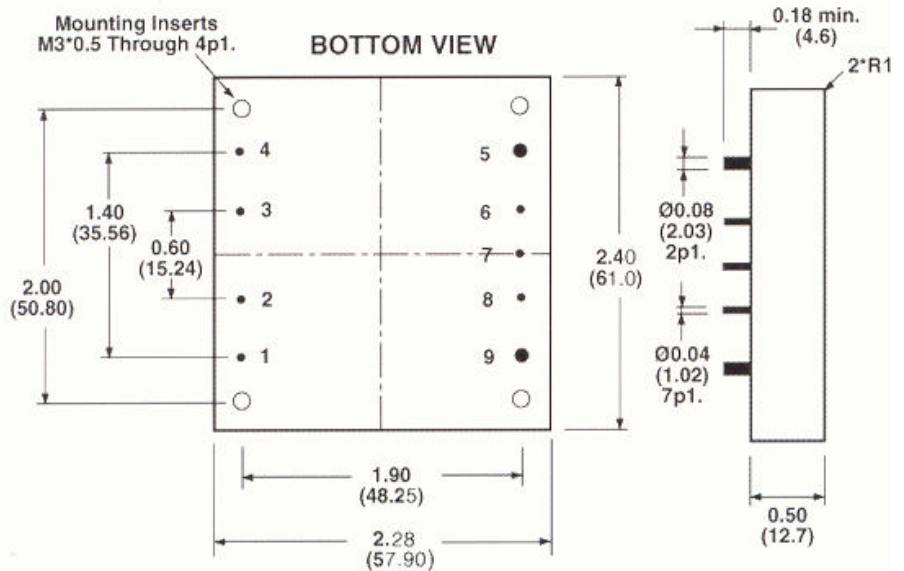

Tolerance	
Inches	Millimeters
•XX ± 0.020	•X ± 0.5
•XXX ± 0.010	•XX ± 0.25
Pin: ± 0.002	± 0.05

The information and specifications contained in this specification are believed to be accurate and reliable at the time of publication. Specifications are subject to change without notice.

Technical Specification

HB75-48 Series

48Vin 2.5, 3.3, 5, 12, 15, 24Vout 75W

Electrical Specification

Typical test data at Ta=25°C, Vin=48V unless otherwise noted.

PARAMETER	NOTES	MIN	TYP	MAX	UNIT
Absolute maximum rating					
Input voltage		0		80	V
Operating case temperature		-40		100	°C
Storage temperature		-40		105	°C
Humidity				95	%
Input characteristics					
Operating input voltage range		36		75	V
Turn on voltage threshold		33	34	35	V
Turn off voltage threshold		31	33	35	V
Off converter input current	36Vin		5		mA
Output characteristics					
Output voltage					
HB75-48-25 or HB75-48-25N	36-75Vin, no load to full load	2.47	2.50	2.53	V
HB75-48-33 or HB75-48-33N	36-75Vin, no load to full load	3.25	3.30	3.35	V
HB75-48-05 or HB75-48-05N	36-75Vin, no load to full load	4.85	5.00	5.15	V
HB75-48-12 or HB75-48-12N	36-75Vin, no load to full load	11.7	12.0	12.3	V
HB75-48-15 or HB75-48-15N	36-75Vin, no load to full load	14.5	15.0	15.5	V
HB75-48-24 or HB75-48-24N	36-75Vin, no load to full load	23.5	24.0	24.5	V
Output current					
HB75-48-25 or HB75-48-25N		0		15	A
HB75-48-33 or HB75-48-33N		0		15	A
HB75-48-05 or HB75-48-05N		0		15	A
HB75-48-12 or HB75-48-12N		0		6.25	A
HB75-48-15 or HB75-48-15N		0		5.0	A
HB75-48-24 or HB75-48-24N		0		3.13	A
Output voltage trim range	Percentage of normal output	-10		+10	%
Output voltage ripple and noise	20Mz bandwidth, 100% Load, 48Vin, for 2.5,3.3,5,12,15V For 24V		100	150 240	mV(pk-pk) mV(pk-pk)
Output over power protection		110	120	140	%
Over-voltage protection			130	150	%
Over-temperature protection			105	110	°C
Temperature coefficient				±0.05	%/°C
Output dynamic characteristics					
Startup time	5% to 95% of the output voltage			20	ms
Transient recovery time	25% load change (2.0A/us)			800	µs
Transient Peak	25% load change (2.0A/us)			400	mV
Efficiency					
HB75-48-25 or HB75-48-25N			77		%
HB75-48-33 or HB75-48-33N			79		%
HB75-48-05 or HB75-48-05N			82		%
HB75-48-12 or HB75-48-12N			89		%
HB75-48-15 or HB75-48-15N			85		%
HB75-48-24 or HB75-48-24N			86		%
Isolation characteristics					
Isolation voltage(primary to secondary)	1minute		1500		VDC

Technical Specification

BTCPower™

HB75-48 Series

48Vin 2.5, 3.3, 5, 12, 15, 24Vout 75W

Isolation voltage (primary to case)	1minute		1000		VDC
Isolation voltage (secondary to case)	1minute		500		VDC
Isolation resistance	500VDC, Primary to secondary	10			MΩ

Basic operation and functions

The **HB family** uses planar transformer technology to achieve high output current. The whole unit switches at the fixed frequency for a predictable EMI performance. The **HB Brick** has many standard controls and protection functions.

Input Power (pin1, pin4)

Input power $V_{in}(+)$ must be connected to Positive input voltage pin1; Input power $V_{in}(-)$ must be connected to Negative input voltage pin4.

Output Power (pin9, pin5)

Output power $V_{out}(+)$ must be connected to Positive output voltage pin9; Output power $V_{out}(-)$ must be connected to Negative output voltage pin5.

On/Off (pin 2)

Permits the user to maintain unit On/Off, in order to properly sequence different power supplies and reduce power consumption during the standby condition. There are two remote control options available, positive logic and negative logic is referenced to $V_{in}(-)$, and typical connections are shown in Fig 1.

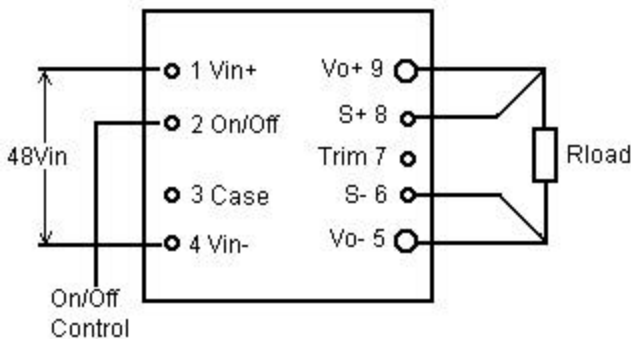

Fig. 1: Typical Circuit for On/Off Function

Pin 2 is the "Enable" pin, connecting a TTL compatible pin. A TTL control signal to this pin,

according to the specification, will turn the unit on or off.

The positive logic version turns on when pin 2 is at logic high, and turns off when pin 2 is at logic low. The unit is on when pin 2 is left open.

The negative logic version turns on when pin 2 is at logic low and turns off when pin 2 is at logic high. The pin 2 can be directed to $V_{in}(-)$, to enable automatic turn on to the unit without the need of an external control signal.

Remote Sense (pin 8, pin 6)

Permits the user to maintain the accurate output voltage at the remote load terminals regardless of the line drop.

The Sense(-) (pin6) and Sense(+) (pin8) should be connected at the load or at the point where the regulation is needed. (shown on Fig. 2)

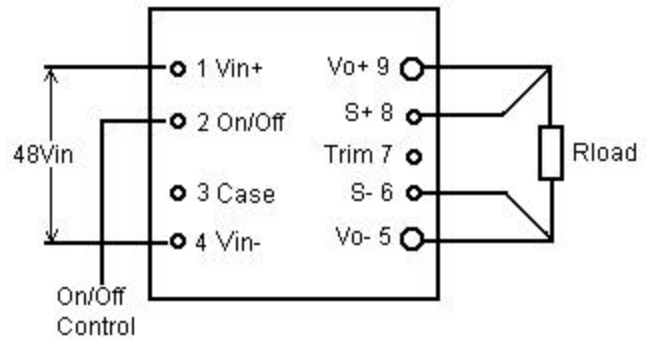

Fig 2: Remote Sense Circuit

The remote sense feature of the unit compensates for voltage drop occurring between the output pins of the unit and load. The Sense(-) (pin5) and Sense(+) (pin7) should be connected at the load or at the point where regulation is required.

If remote Sense is not required, the Sense(-) pin must be connected to the $V_{out}(-)$ pin (pin5), and

the Sense(+) pin must be connected to the Vout(+) pin(pin 9) to ensure the unit will regulate at the specified output voltage. If these connections are not made, the unit's output voltage will be higher than the specified value.

The unit output over voltage protection senses the voltage across Vout(+) and Vout(-), and not across the sense lines, so the resistance between the output pins of the unit and the load should be minimized to prevent unwanted triggering of the OVP.

When using the remote sense feature, the output voltage at the unit can be increased by as much as 10% above the normal rating, in order to maintain the required voltage across the load. Therefore, the designer must consider this condition.

Also when using the remote sense function, the output power must be taken care of, as not to exceed the maximum power capability of the unit.

Output Voltage Trim (pin 7)

Permits the user to adjust the output voltage up or down to achieve the custom voltage or to make the output voltage margining. The adjustment range is from + 10% to -10%.

Output voltage can be adjusted up or down, by connecting the Rtrim-up or Rtrim-down resistor as shown. Rtrim-up makes the output voltage go up to 10%; and the Rtrim-down makes the output voltage go down to 10%.

Leave Trim pin (Pin 7) open for normal output voltage.

When trimming up, care must be taken, not to exceed the unit OVP threshold. A typical circuit is shown in Fig. 3.

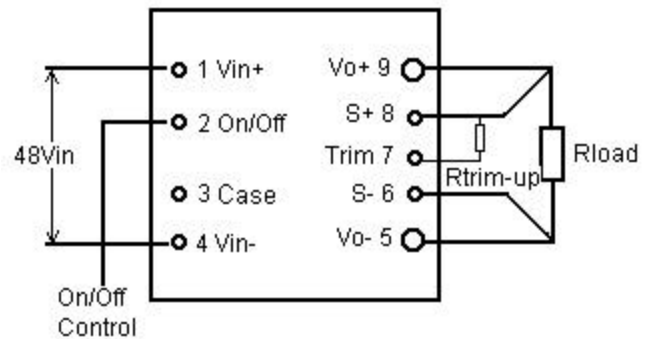

Fig 3. Trim Up Output Voltage Circuit

Trimming down the output voltage for a typical circuit, as shown on Fig. 4.

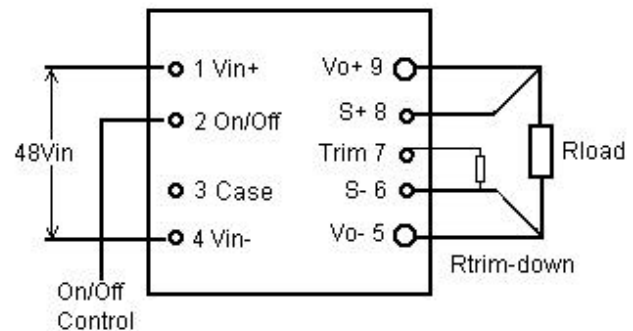

Fig 4. Trim Down Output Voltage Circuit

Protection Features

Input Under-voltage lockout (IUV)

Input under voltage (IUV) is standard with the HB unit. The unit will shut down when the input voltage drops below a threshold, and the unit will turn on when the input voltage goes to the upper threshold.

The hysteric voltage of the under voltage protection is 1.5V, normally from the 33.5V to 35V range.

Output Over-current Protection (OCP)

The unit will shut down when the over current or short circuit condition exists.

Once the OCP happens, the unit has shut down. The attempted restart will continue indefinitely

until the over current or short circuit condition is removed. When OCP happens, the output voltage drops below 1.1V.

Input voltage has almost no effect on the current limit point.

Output Over-voltage Protection (OVP)

The unit will shut down when the output voltage exceeds the over voltage threshold.

If the output voltage across Vout(+) (pin9) and Vout(-) (pin5) exceeds the threshold of the OVP circuitry, the unit has shut down which is caused by an OVP circuit, and the unit will never restart, and the output voltage is below 0.5V.

Over Temperature Protection (OTP)

The unit will shut down when the base plate temperature exceeds the protection threshold.

The unit will shut down under the base plate temperature over a 105°C condition to protect the unit from overheating. The OTP circuit will turn the unit off when OTP happens. Once the unit has shut down, it will restart at the cycle when the base plate temperature goes down.

Application information

Input Source Impedance

The unit has been designed to be stable with no external capacitors when used in a low inductance input and output circuit.

However in many applications, the inductance with the distribution from the power source to the input of the unit can affect the stability of the unit. The addition of 47uF electrolytic capacitor with an $Esr < 1\Omega$ (at 100kHz) across the input can ensure the stability of the unit. Also in many applications, the user has to use decoupling capacitors at the output load, to ensure the hold up time for the load.

Safety Requirements and Considerations

The unit meets the American and International safety regulatory requirement UL1950. Basic insulation is also provided between the input side and the output side.

To meet safety agencies requirements, an input line fuse must be used external to the unit. An 8A fuse or less with a normal blow rate must be used to meet the safety agencies requirements. A minimum 42LFM airflow should also be provided if the unit is intended to operate at full power without heatsink.

If the input source is non-SELV (ELV or a hazardous voltage greater than 60 Vdc and less than or equal to 75 Vdc), for the unit output to be considered meeting the requirements of safety extra low voltage (SELV), all of the following must be met:

- The input source is to be provided with reinforced insulation from any hazardous voltage, including the ac main.
- The input pins of the unit are not operator accessible.
- For whole system, for safety agencies requirements, and for the combination of the unit's input side (primary side) and the unit's output side (secondary side), verify that under a single fault, hazardous voltages do not appear at the unit's output side (secondary side).
- Never ground either of the input pins of the unit without grounding one of the output pins. This may allow a non-SELV voltage to appear between the output pin and ground.